

Customer :  
 Project Name :  
 Project No. :  
 Revision No. :

# SPECIFICATION for INDUCTION MOTOR



0		For Bidding			
No.	DATE	DESCRIPTION	PREPARED BY	CHECKED BY	APPROVED BY



# AC INDUCTION MOTOR DATA SHEET

## IEEE841 TYPE

Catalog No.	IEEE700-36-5812S-IBSHSP	Item No.	Rev. No.	[       ]
Project Name		Project No.	Quantity	sets

GENERAL SPECIFICATION			PERFORMANCE DATA			
Frame Size	5812S		Rated Output	522 kW      700 HP		
Type	HNE6		Number of Poles	2		
Enclosure(Protection)	Totally Enclosed	/ IP55	Rotor Type	Squirrel Cage		
Method of Cooling	IC411(FC)		Starting Method*	D.O.L		
Rated Frequency	60 Hz		Rated Voltage	575 V	460 V	230 V
Number of Phases	3		Current	Full Load	614.7 A	768.4 A    1,536.8 A
Insulation Class	F			Locked-rotor**	720 %	720 %    720 %
Temp. Rise at full load (by resistance method)			Efficiency			
at 1.0 S.F	80 deg. C		50% Load		92.8 %	
Motor Location	<input type="checkbox"/> Indoor <input type="checkbox"/> Outdoor		75% Load		94.8 %	
Altitude	Less than 1,000 meter		100% Load		95.8 %	
Relative Humidity	Less than 80 %		Power Factor(p.u)			
Ambient Temp.	40 deg. C (Max.)		50% Load		0.740	
Duty Type	Continuous ( S1 )		75% Load		0.840	
Service Factor	1.15		100% Load		0.890	
Mounting	B3		Speed at Full Load	3570 r.p.m		
Bearing	Type	Anti-Friction	Torque			
	DE/N-DE	6316C3 / 6316C3-INS.	Full Load	1,030.1 lb.ft		
	Lubricant	Grease(Polyrex-EM)	Locked-rotor**	150 %		
External Thrust	Not applicable		Breakdown**	250 %		
Coupling Method	<input checked="" type="checkbox"/> Direct <input type="checkbox"/> V-belt		Moment of Inertia (J)			
Shaft Extension	Single		Load(Max.)	513.845 lb.ft2		
Terminal Box	Main	Steel	Motor	121.840 lb.ft2		
	Aux.	Yes	Sound Pressure Level (No-load & mean value at 1m from motor)			
Location	Refer to Outline Drawing				89 dB(A)	
Application			Vibration		3.8 mm/sec (peak)	
Area classification	Hazardous		Permissible number of consecutive starts		Cold    2 times Hot     1 time	
Type of Ex-Protection	Class I, Division 2		Paint	Munsell No.	7.5BG6/1.5	
Applicable Standard	IEEE841, NEMA MG1, CSA C390					

ACCESSORIES
*. Space Heater : 1EA/Motor

SUBMITTAL DRAWING
Outline Dimension Drawing \ Motor Weight(Approx.)
B3      LM-I5812B3CE001      6730 lb.

SPARE PARTS
1. Spare Axial Fan (C.W Direction)

REMARK										
<ol style="list-style-type: none"> <li>1. Premium efficiency according to NEMA MG1</li> <li>2. Inverter Duty @ 1.0 Service Factor &amp; F Temperature rise               <ul style="list-style-type: none"> <li>-. 10:1 VT</li> <li>-. 2:1 CT</li> </ul> </li> <li>3. NDE side : Insulated bearing</li> <li>4. CSA Certification               <ul style="list-style-type: none"> <li>-. Class I, Division 2, Group A, B, C &amp; D; Temp code : T3A</li> </ul> </li> <li>5. Shaft material : AISI4140</li> <li>6. Uni-directional CCW viewed from drive end.</li> </ol>										
<table border="1" style="width: 100%; border-collapse: collapse;"> <tr> <td>Date</td> <td>DSND</td> <td>CHKD</td> <td>CHKD</td> <td>APPD</td> </tr> <tr> <td>2024-09-22</td> <td>E.J.LEE</td> <td>I.K. Kim</td> <td>R.G. Kim</td> <td>S.W. Kim</td> </tr> </table>	Date	DSND	CHKD	CHKD	APPD	2024-09-22	E.J.LEE	I.K. Kim	R.G. Kim	S.W. Kim
Date	DSND	CHKD	CHKD	APPD						
2024-09-22	E.J.LEE	I.K. Kim	R.G. Kim	S.W. Kim						

[Note] Others not mentioned in this data sheet shall be in accordance with maker standard.  
 Above technical data are only design values and shall be guaranteed with tolerance of applicable standard.  
 Inspection and performance test shall be done according to maker standard, if not mentioned.  
 \* In case of Inverter-Fed Motor, performance data is based on sine wave tests. It may be different from test data of Inverter combined motor.  
 \*\* Data is based on rated voltage & frequency and is expressed as a percentage of full-load value.

	REV	DATE	CONTENTS

4.72

CROWN TRITON

Premium Efficiency AC 3 Phase Motor

700HP 2P 460V	Cat. No. IEEE700-36-5812S-IBSHSP
Model LATER	INS. Class F Amps 768.4
Type HNE6 Duty CONT	Code G Amb. 40°C Hertz 60Hz
Frame 5812S Encl. TEFC	S.F. 1.15 RPM 3570 NEMA Norm. Eff. 95.8%
Bearing	Drive 6316C3 S.F.1.00 (2:1 C.T., 10:1 V.T., NEMA-MG1 Part31) 3/4 Eff. 94.8%
	Opp. 6316C3-INS. NEMA Design B Torque
Usable at	50Hz 535HP 380V 720.89A 2970rpm S.F.: 1.15 Eff.: 95.8% Code: H 50Hz 535HP 400/415V 692.72/675.37A 2972/2975rpm S.F.: 1.15 Eff.: 95.8/95.81% Code: J/J
CSA Certified for	CLASS I, Div. 2, Gr. A, B, C & D Temp. Code (sine wave) Frame 580FR Maximum Amb. 50°C T3A (180°C)
No. -	Date - Weight 6730 lb

IEEE Std 841-2021 4M-136445

Made in Korea H1

APPD BY	S.Y.KIM	UNIT	INCH	SUBJECT	CSA Class I, Division2 IEEE841 (XL)	DWG SIZE
CHKD BY	I.K.KIM	SCALE	NONE	TITLE	NAMEPLATE DRAWING	A4 ( 1:1 )
CHKD BY	R.G.KIM	PROJEC'N	3rd Angle			
DSND BY	S.H.LEE	DATE	2024.06.07			
				REF. NO	4M-136445	Sheet No. of
				DWG NO	NP-IEEE700-36-5812S-IBSHSP	Revision No. 0



# PERFORMANCE CURVE

CURVE NO.  
PC-IEEE700-36-5812S-IBSHSP

Type :	HNE6	
Full Load Torque :	1030.1	lb.ft
Load moment of Inertia (J) :	513.845	lb.ft2
Motor moment of Inertia (J) :	121.840	lb.ft2

522kW	700HP	2 P	60 Hz
Speed at Full Load :			3570 RPM
Rated Voltage	575V	460V	230V
Full Load Current	614.7A	768.4A	1536.8A

SPEED VS TORQUE & CURRENT CURVE

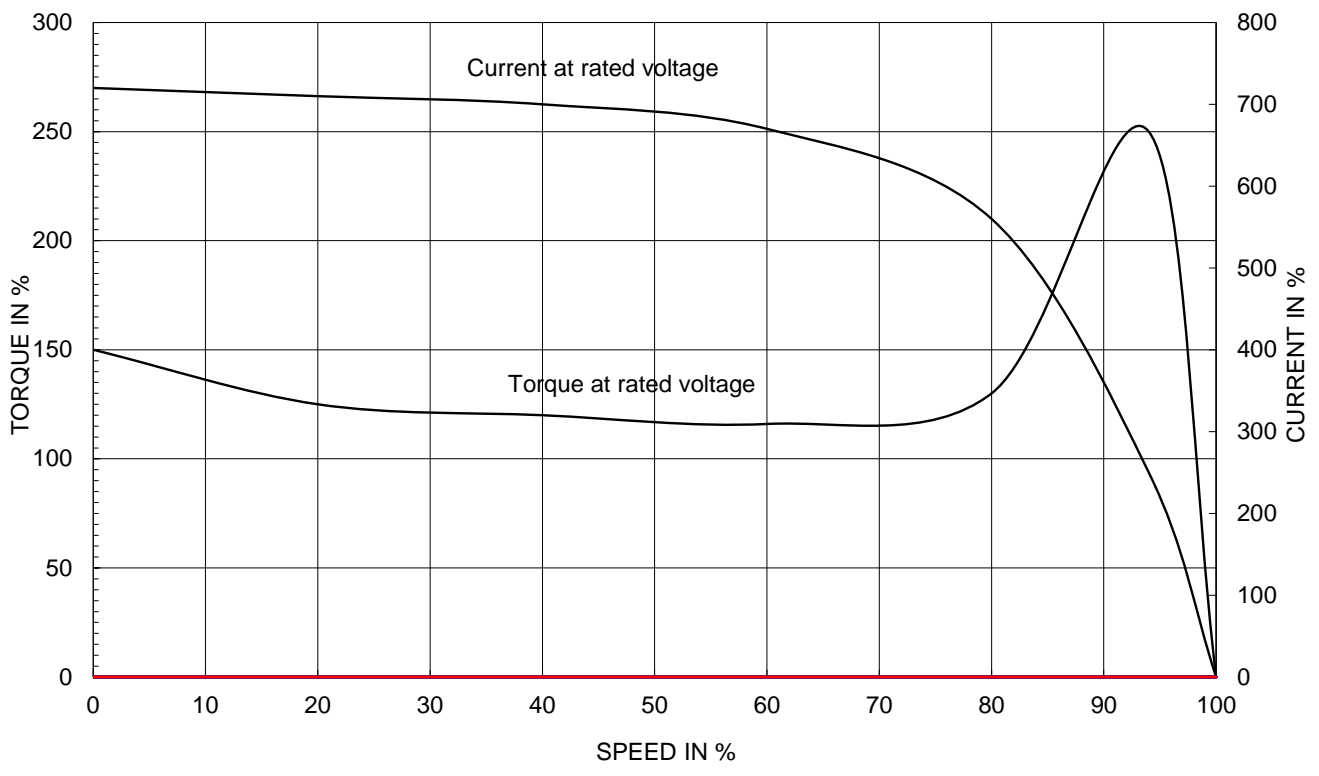

OUTPUT VS EFF., P.F & CURRENT CURVE

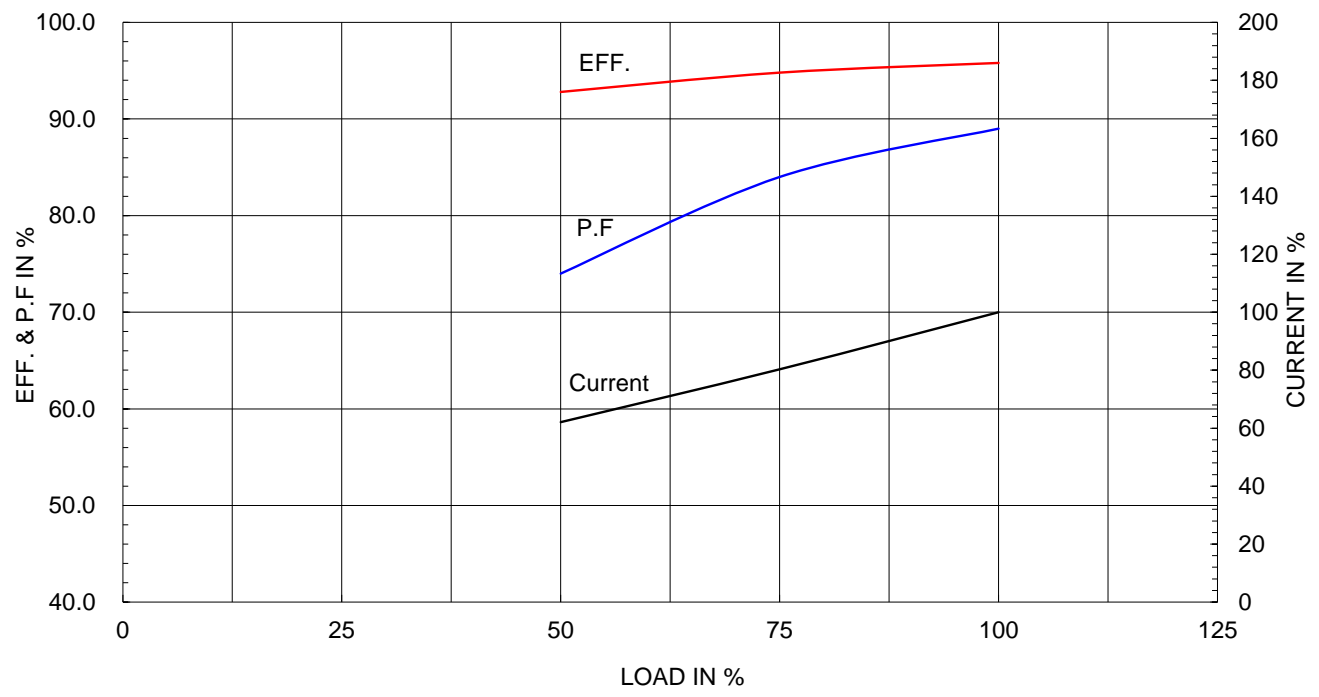

THIS DRAWING IS PROPRIETARY TO HYUNDAI ELECTRIC. NO PART OF THIS DRAWING MAYBE REPRODUCED WITHOUT THE PERMISSION OF HYUNDAI ELECTRIC.

HD HYUNDAI ELECTRIC  
 본 도면은 HD현대일렉트릭(주) 재산이며 허가없이 복사할 수 없음 (취급주의)

# IEEE841

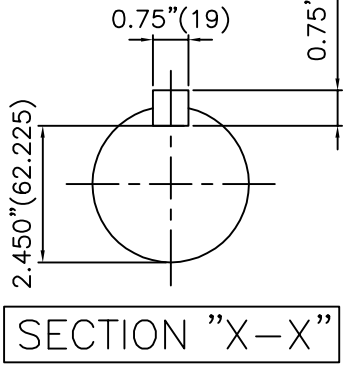
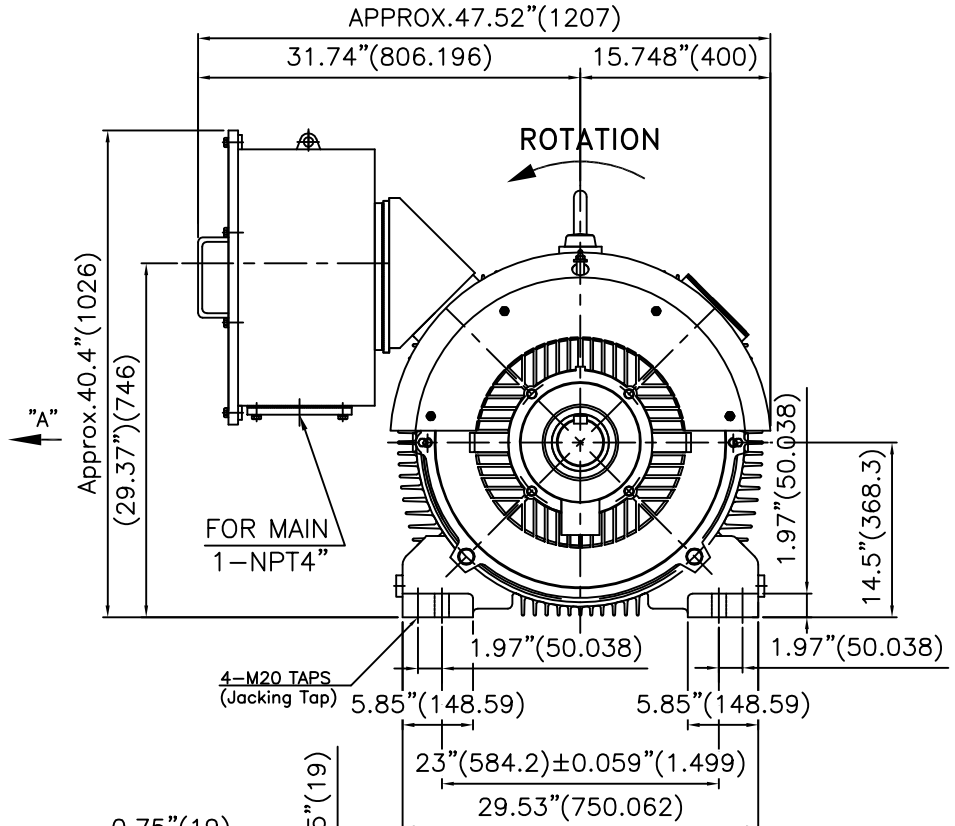
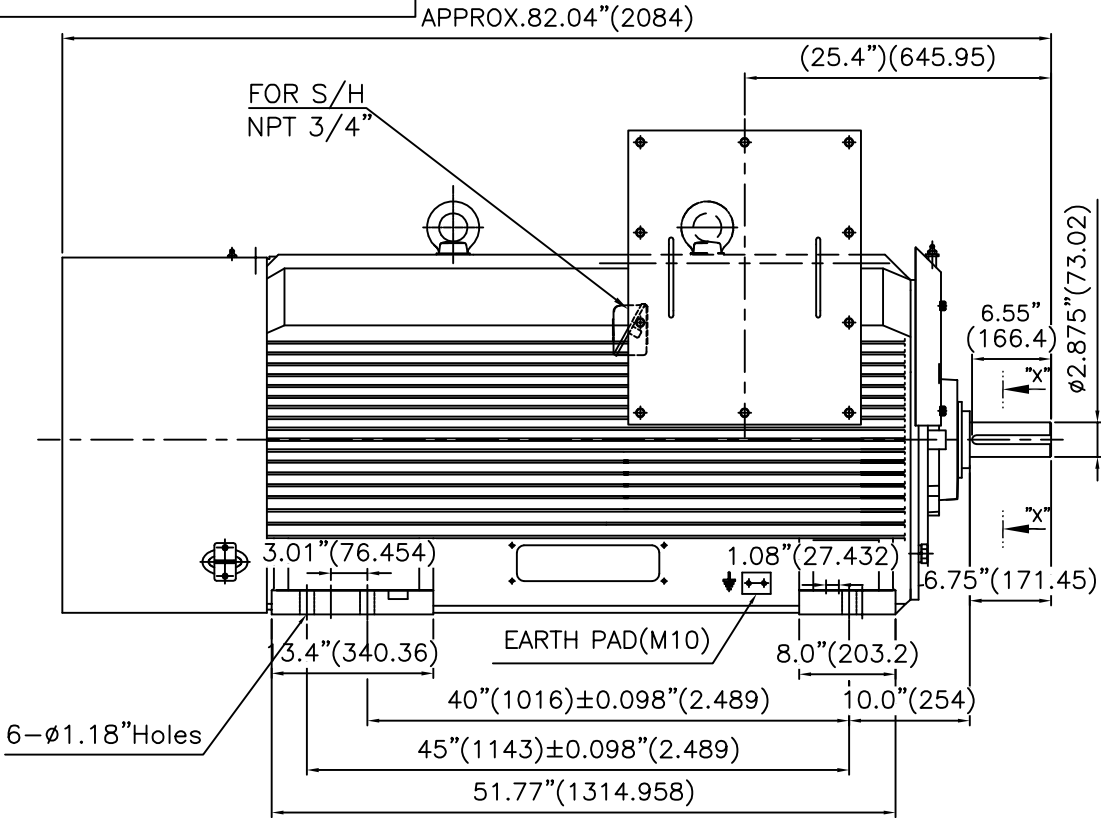

### TECHNICAL INFORMATION

#### 1) BEARING & LUBRICANT LIST

BEARING	Drive End	Non-Drive End
Bearing Type	6316C3	6316C3
Lubricant Type	GREASE	GREASE
Grease Type	Mobil(Polyrex-EM)	Mobil(Polyrex-EM)
Initial Charge Quantity	200 g	200 g
Mark-Up	Quantity	33 g
	Interval	2 MONTHS

#### 2) TOLERANCE :

CENTER HEIGHT	14.5	+0.000	-0.060
SHAFT DIAMETER	ø2.875	+0.000	-0.001
KEYWAY WIDTH	0.75	+0.003	-0.000

VIEW "A"

SECTION "X-X"

Q'TY	DESCRIPTION	MATERIAL	DIMENSION	WEIGHT	PART NO.	REMARK
APPD BY	S.K.HAN	UNIT	INCH(MM)	SUBJECT Fr.5812-2P		
CHKD BY	S.Y.KIM	SCALE	1/12	TITLE		
CHKD BY	R.G.KIM	PROJEC'N	3각법 (3rd Angle)	OUTLINE		
DSND BY	M.S.HA	DATE	2019.05.16	REF. NO		
				DWG NO		LM-I5812B3CE001
				Sheet No. of		Revision No.

REV	DATE	CONTENTS	REVD BY	CHKD BY	CHKD BY	APPD BY
1						

**Cls. I&II, Div. 2  
IEEE 841**

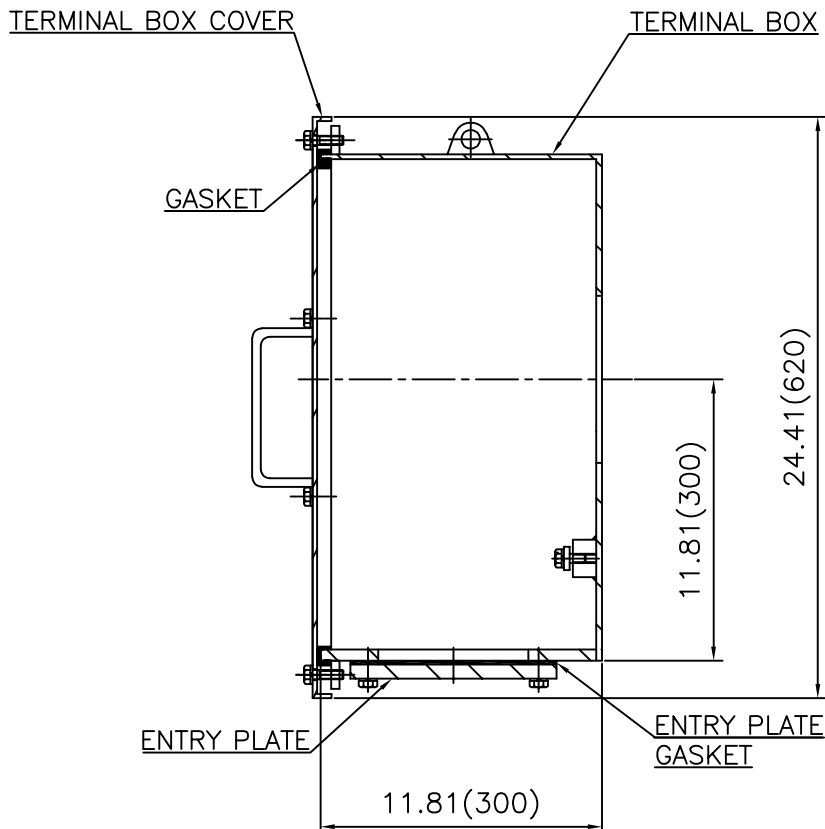
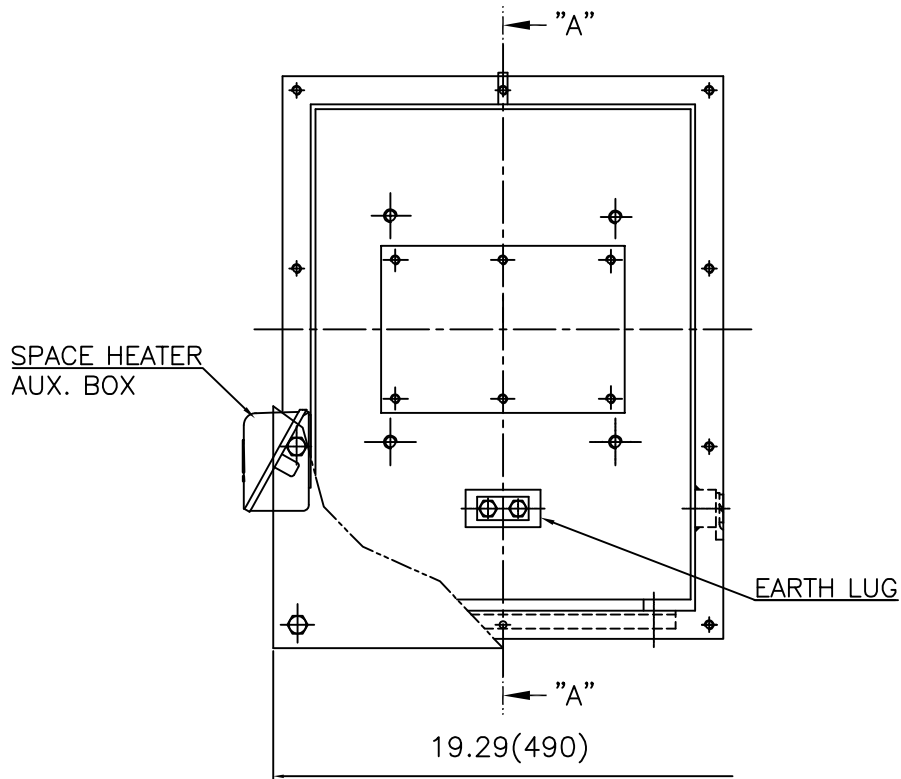

SEC. "A" - "A"

REV	DATE	CONTENTS	REVD BY	CHKD BY	CHKD BY	APPD BY
1						
2						
3						
4						

APPD BY	S.Y.KIM	UNIT	inch(mm)	SUBJECT	FR.580 (STEEL)	DWG SIZE	A3 (1:6)
CHKD BY		SCALE	1/6	TITLE	MAIN TERMINAL BOX ASS'Y		
CHKD BY	R.G.KIM	PROJEC'N	3rd Angle	REF. NO		Sheet No.	of
DSND BY	박승희	DATE	2023-10-25	DWG NO	3M-248512	Revision No.	0



**Cls. I&II, Div. 2  
IEEE 841**



SEC. "A" - "A"

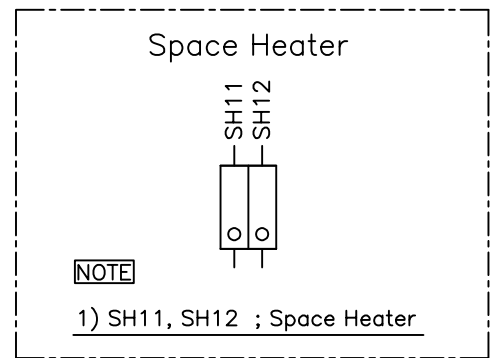

REV	DATE	CONTENTS	REVD BY	CHKD BY	CHKD BY	APPD BY

APPD BY	S.Y.KIM	UNIT	inch(mm)	SUBJECT	FR.180 (CAST IRON)	DWG SIZE
CHKD BY		SCALE	1/1	TITLE	SUB. TERMINAL BOX ASS'Y	A3 (1:1.1)
CHKD BY	R.G.KIM	PROJEC'N	3rd Angle			
DSND BY	배승희	DATE	2024-01-18			
				REF. NO		Sheet No. of
				DWG NO	3M-165278	Revision No. 0