

Customer :
 Project Name :
 Project No. :
 Revision No. :

SPECIFICATION for INDUCTION MOTOR



0		For Bidding			
No.	DATE	DESCRIPTION	PREPARED BY	CHECKED BY	APPROVED BY



AC INDUCTION MOTOR DATA SHEET

IEEE841 TYPE

Catalog No.	IEEE450-18-5009-IBSH	Item No.	Rev. No. []
Project Name		Project No.	Quantity sets

GENERAL SPECIFICATION		PERFORMANCE DATA			
Frame Size	5009	Rated Output	335 kW 450 HP		
Type	PJP	Number of Poles	4		
Enclosure(Protection)	Totally Enclosed / IP55	Rotor Type	Squirrel Cage		
Method of Cooling	IC411(FC)	Starting Method*	D.O.L		
Rated Frequency	60 Hz	Rated Voltage	575 V	460 V	230 V
Number of Phases	3	Current	Full Load	392.9 A	491.1 A
Insulation Class	F		Locked-rotor**	720 %	720 %
Temp. Rise at full load (by resistance method)		Efficiency			
at 1.0 S.F	80 deg. C	50% Load		93.2 %	
Motor Location	<input type="checkbox"/> Indoor <input type="checkbox"/> Outdoor	75% Load		95.2 %	
Altitude	Less than 1,000 meter	100% Load		96.2 %	
Relative Humidity	Less than 80 %	Power Factor(p.u)			
Ambient Temp.	40 deg. C (Max.)	50% Load		0.740	
Duty Type	Continuous (S1)	75% Load		0.840	
Service Factor	1.15	100% Load		0.890	
Mounting	B3	Speed at Full Load	1785 r.p.m		
Bearing	Type	Anti-Friction	Torque		
	DE/N-DE	NU324 / 6320C3-INS.	Full Load	1,322.2 lb.ft	
	Lubricant	Grease(Polyrex-EM)	Locked-rotor**	135 %	
External Thrust	Not applicable	Breakdown**	230 %		
Coupling Method	<input type="checkbox"/> Direct <input type="checkbox"/> V-belt	Moment of Inertia (J)			
Shaft Extension	Single	Load(Max.)	1,710.000 lb.ft2		
Terminal Box	Main	Cast Iron	Motor	158.058 lb.ft2	
	Aux.	Yes	Sound Pressure Level (No-load & mean value at 1m from motor)		
Location	Refer to Outline Drawing	85 dB(A)			
Application		Vibration			
Area classification	Hazardous	3.8 mm/sec (peak)			
Type of Ex-Protection	Class I&II, Division 2	Permissible number of consecutive starts	Cold	2 times	
Applicable Standard	IEEE841, NEMA MG1, CSA C390	Hot	1 time		
		Paint	Munsell No.	7.5BG6/1.5	

ACCESSORIES
*. Space Heater : 1EA/Motor

SPARE PARTS

SUBMITTAL DRAWING		
Outline Dimension Drawing	Motor Weight(Approx.)	
B3	LM-I0509B3PE001	3970 lb.

REMARK

1. Premium efficiency according to NEMA MG1
2. Inverter Duty @ 1.0 Service Factor & F Temperature rise
 - . 10:1 VT (20:1 VT at 50% load)
 - . 10:1 CT
 - . CHp up to 1.5 times base speed, NEMA MG1 Part31
3. NDE side : Insulated bearing
4. CSA Certification
 - . Class I, Division 2, Group A, B, C & D; Temp code : T3
 - . Class II, Division 2 Group F & G; Temp code : T3
5. Shaft material : AISI4140

Date	DSND	CHKD	CHKD	APPD
2024-09-22	E.J.LEE	I.K. Kim	R.G. Kim	S.W. Kim

[Note] Others not mentioned in this data sheet shall be in accordance with maker standard.
 Above technical data are only design values and shall be guaranteed with tolerance of applicable standard.
 Inspection and performance test shall be done according to maker standard, if not mentioned.
 * In case of Inverter-Fed Motor, performance data is based on sine wave tests. It may be different from test data of Inverter combined motor.
 ** Data is based on rated voltage & frequency and is expressed as a percentage of full-load value.

	REV	DATE	CONTENTS

4.72

2.36

CROWN TRITON
Premium Efficiency AC 3 Phase Motor

450HP	4P	460V	Cat. No.	IEEE450-18-5009-IBSH			
Model	LATER		INS. Class	F		Amps	491.1
Type	PJP	Duty	CONT	Code	G	Amb.	40°C
Frame	5009	Encl.	TEFC	S.F.	1.15	RPM	1785
Bearing	Drive	NU324		S.F.1.00 (10:1 C.T., 20:1 V.T., NEMA-MG1 Part31)		NEMA Nom. Eff.	96.2%
	Opp.	6320C3-INS.				3/4 Eff.	95.2%
Usable at	50Hz 335HP 380V 449.62A 1485rpm S.F.: 1.15 Eff.: 96% Code: H						
	50Hz 335HP 400/415V 426.69/416A 1486/1487rpm S.F.: 1.15 Eff.: 96.1/96.1% Code: J/K						
CSA Certified for	CLASS I, Div. 2, Gr. A, B, C & D		CLASS II, Div. 2, Gr. F & G		Temp. Code (sine wave)	Frame	L440FR - 500FR
	CLASS I, Zone 2, Gr. IIA, IIB, & IIC					Amb. 40°C	T3 (200°C)
						Amb. 55°C	T3 (200°C)
No.	-		Date	-		Weight	3970 lb

IEEE Std 841-2021 MARINE DUTY IEEE45
4M-136054 Made in Korea H1

HD HYUNDAI ELECTRIC

APPD BY	S.Y.KIM	UNIT	INCH	SUBJECT	CSA Class I, Division2 IEEE841 (XL)	DWG SIZE
CHKD BY	I.K.KIM	SCALE	NONE	TITLE	NAMEPLATE DRAWING	A4 (1:1)
CHKD BY	R.G.KIM	PROJEC'N	3rd Angle			
DSND BY	S.H.LEE	DATE	2024.06.07			
HD HYUNDAI ELECTRIC				REF. NO	4M-136054	Sheet No. of
				DWG NO	NP-IEEE450-18-5009-IBSH	Revision No. 0

Type :	PJP
Full Load Torque :	1322.2 lb.ft
Load moment of Inertia (J) :	1710.000 lb.ft2
Motor moment of Inertia (J) :	158.058 lb.ft2

335kW 450HP	4 P	60 Hz
Speed at Full Load :		1785 RPM
Rated Voltage	575V	460V 230V
Full Load Current	392.9A	491.1A 982.2A

SPEED VS TORQUE & CURRENT CURVE

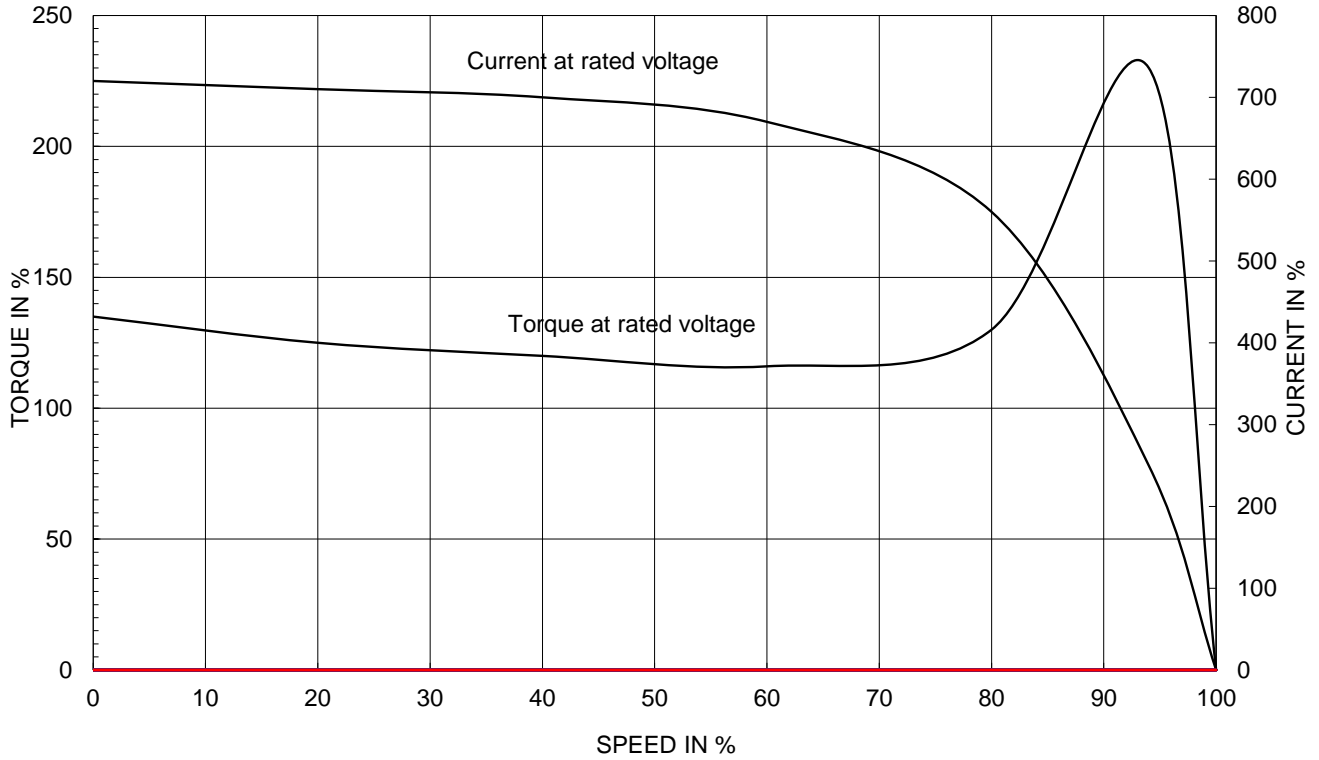

OUTPUT VS EFF., P.F & CURRENT CURVE

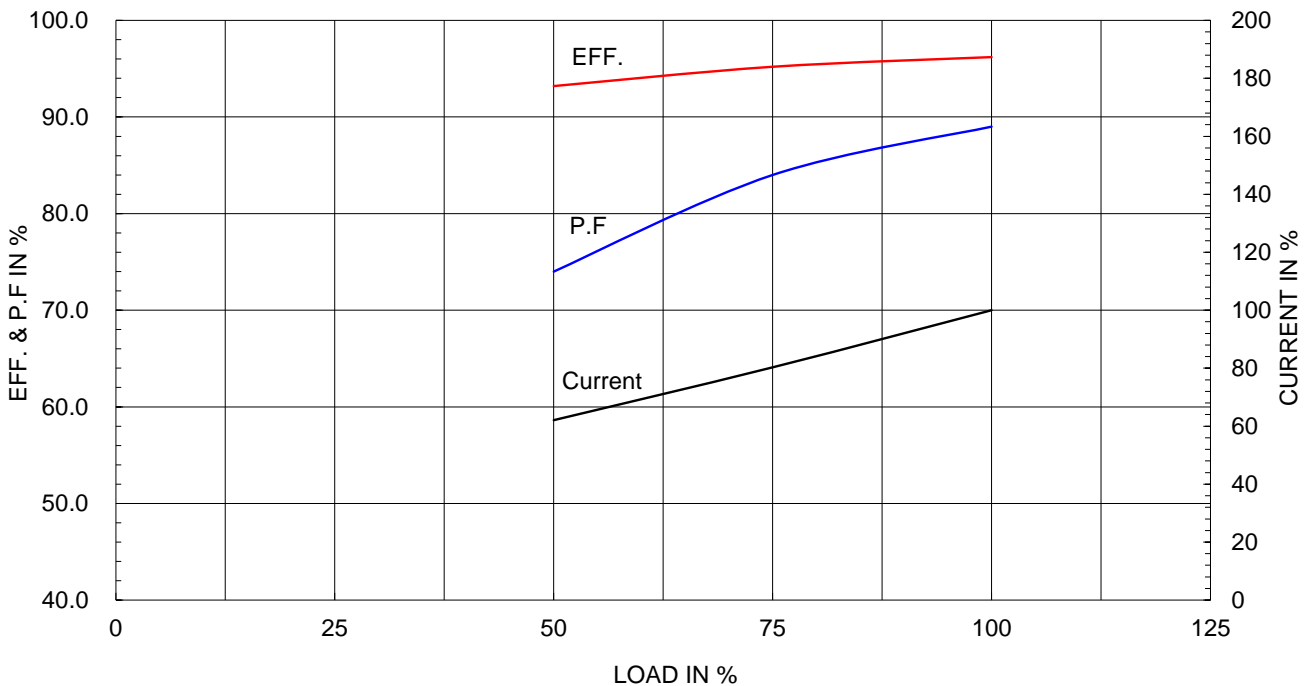

▽	50S	REV	DATE	CONTENTS	REVD BY	CHKD BY	CHKD BY	APPD BY
▽▽	12.5S							
▽▽▽	3.2S							
▽▽▽▽	0.4S							

IEEE841

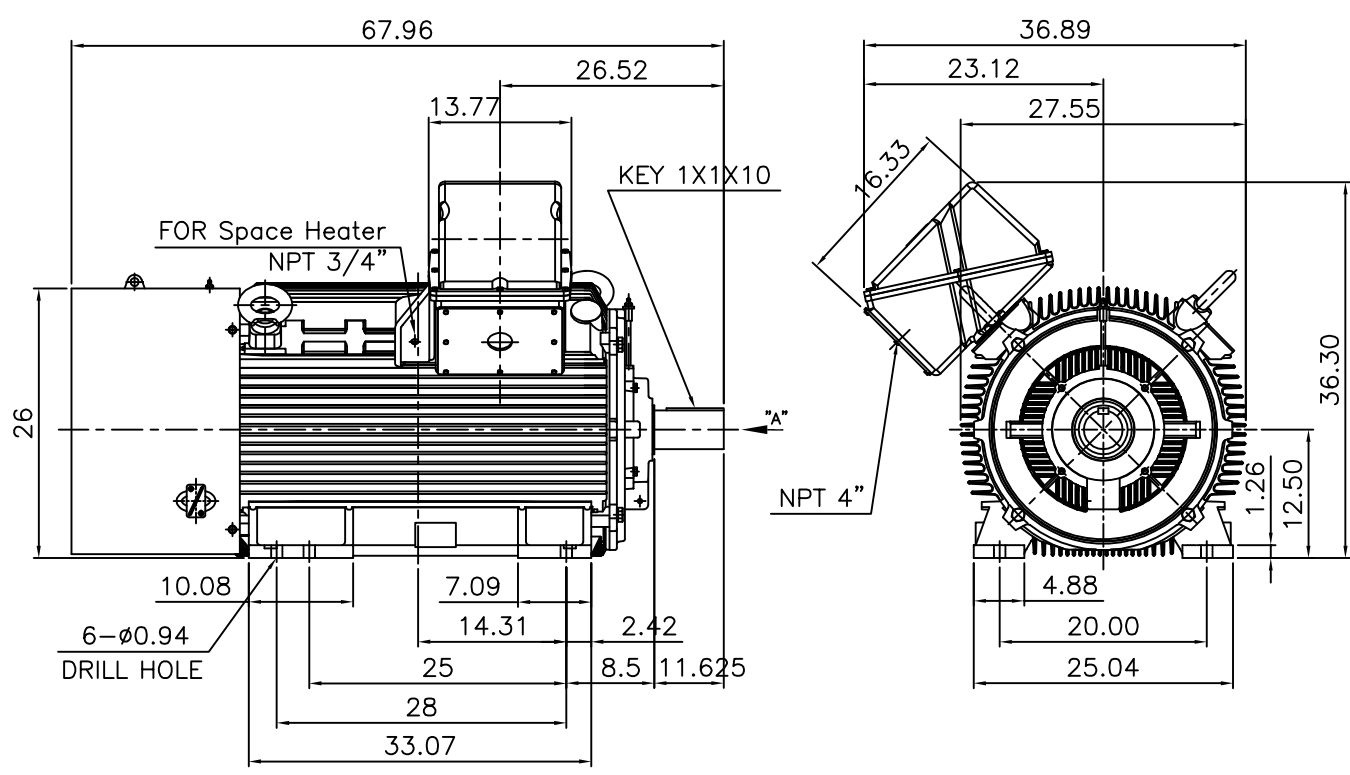

NOTE

1.TOLERANCE :

CENTER HEIGHT	12.5	+0.000	-0.060
SHAFT DIAMETER	ø3.875	+0.000	-0.001
KEYWAY WIDTH	1	+0.003	-0.000

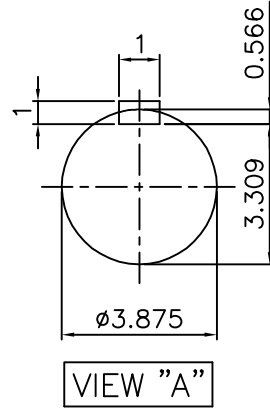

APPD BY	S.Y.KIM	UNIT	INCH	SUBJECT	Fr.5008/5009	DWG SIZE	A4 (1:19)
CHKD BY	O.J.KIM	SCALE	1/19	TITLE	OUTLINE	REF. NO	Sheet No. of
CHKD BY	R.G.KIM	PROJEC'N	3각법(3rd Angle)				
DSND BY	H.K.LEE	DATE	2021-04-27				
				DWG NO	LM-I0509B3PE001	Revision No. 0	

**Cls. I&II, Div. 2
IEEE 841**

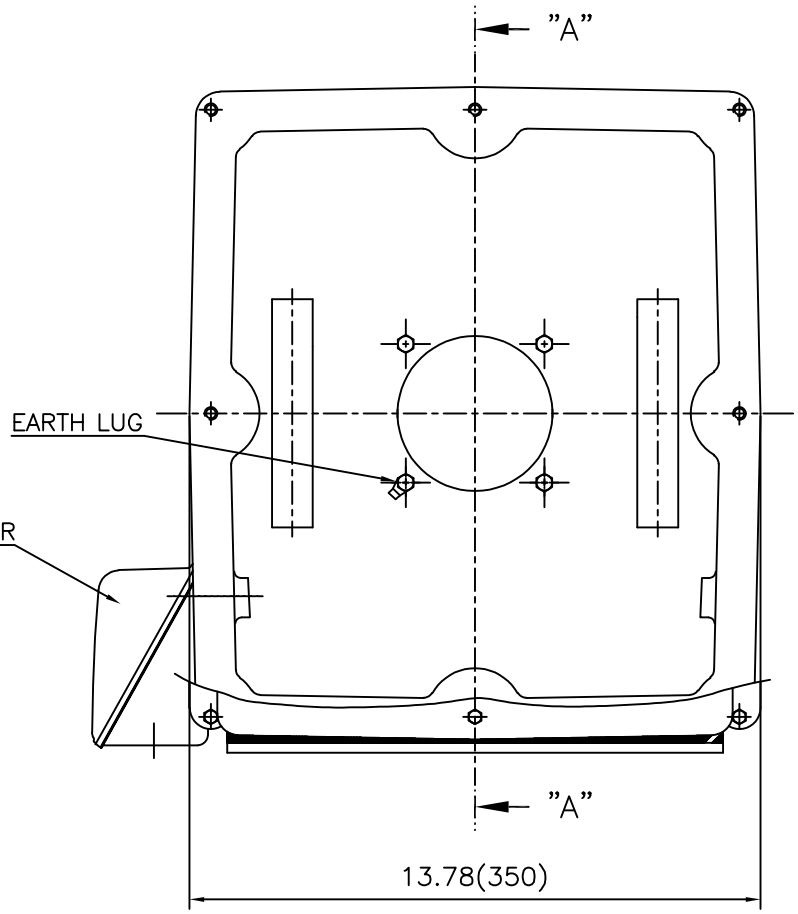

SEC. "A" - "A"

REV	DATE	CONTENTS	REVD BY	CHKD BY	CHKD BY	APPD BY

APPD BY	S.Y.KIM	UNIT	inch(mm)	SUBJECT	FR. L440 (CAST IRON)	DWG SIZE
CHKD BY		SCALE	1/3.5	TITLE	MAIN TERMINAL BOX ASS'Y	A3 (1:3.5)
CHKD BY	R.G.KIM	PROJEC'N	3rd Angle			
DSND BY	최승희	DATE	2023-10-19			
				REF. NO		Sheet No. of
				DWG NO	3M-248452	Revision No. 0

**Cls. I&II, Div. 2
IEEE 841**



SEC. "A" - "A"

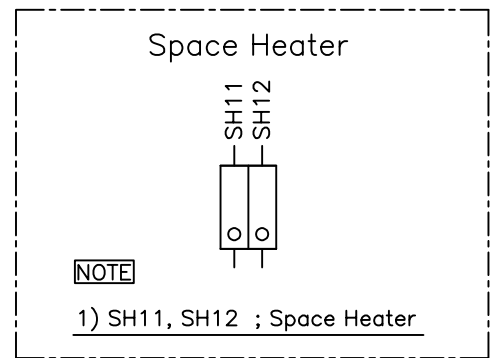

REV	DATE	CONTENTS	REVD BY	CHKD BY	CHKD BY	APPD BY

APPD BY	S.Y.KIM	UNIT	inch(mm)	SUBJECT	FR.180 (CAST IRON)	DWG SIZE
CHKD BY		SCALE	1/1	TITLE	SUB. TERMINAL BOX ASS'Y	A3 (1:1.1)
CHKD BY	R.G.KIM	PROJEC'N	3rd Angle			
DSND BY	배승희	DATE	2024-01-18			
				REF. NO		Sheet No. of
				DWG NO	3M-165278	Revision No. 0