

Customer :
 Project Name :
 Project No. :
 Revision No. :

SPECIFICATION for INDUCTION MOTOR



0		For Bidding			
No.	DATE	DESCRIPTION	PREPARED BY	CHECKED BY	APPROVED BY



AC INDUCTION MOTOR DATA SHEET

IEEE841 TYPE

Catalog No.	IEEE500-12-5011-IBBRSRSH	Item No.		Rev. No.	[]
Project Name		Project No.		Quantity	sets

GENERAL SPECIFICATION			PERFORMANCE DATA			
Frame Size	5011		Rated Output	375 kW		500 HP
Type	PJP		Number of Poles	6		
Enclosure(Protection)	Totally Enclosed	/ IP55	Rotor Type	Squirrel Cage		
Method of Cooling	IC411(FC)		Starting Method*	D.O.L		
Rated Frequency	60 Hz		Rated Voltage	575 V	460 V	230 V
Number of Phases	3		Current	Full Load	467.9 A	584.9 A
Insulation Class	F			Locked-rotor**	675 %	675 %
Temp. Rise at full load (by resistance method)			Efficiency			
at 1.0 S.F	80 deg. C		50% Load		92.8 %	
Motor Location	<input type="checkbox"/> Indoor <input type="checkbox"/> Outdoor		75% Load		94.8 %	
Altitude	Less than 1,000 meter		100% Load		95.8 %	
Relative Humidity	Less than 80 %		Power Factor(p.u)			
Ambient Temp.	40 deg. C (Max.)		50% Load		0.690	
Duty Type	Continuous (S1)		75% Load		0.790	
Service Factor	1.15		100% Load		0.840	
Mounting	B3		Speed at Full Load	1185 r.p.m		
Bearing	Type	Anti-Friction	Torque			
	DE/N-DE	NU324 / 6320C3-INS.	Full Load	2,229.4 lb.ft		
	Lubricant	Grease(Polyrex-EM)	Locked-rotor**	135 %		
External Thrust	Not applicable		Breakdown**	220 %		
Coupling Method	<input type="checkbox"/> Direct <input type="checkbox"/> V-belt		Moment of Inertia (J)			
Shaft Extension	Single		Load(Max.)	4,666.000 lb.ft2		
Terminal Box	Main	Cast Iron	Motor	272.448 lb.ft2		
	Aux.	Yes	Sound Pressure Level (No-load & mean value at 1m from motor)			
	Location	Refer to Outline Drawing	84 dB(A)			
Application			Vibration			
Area classification	Hazardous		3.8 mm/sec (peak)			
Type of Ex-Protection	Class I&II, Division 2		Permissible number of consecutive starts	Cold	2 times	
Applicable Standard	IEEE841, NEMA MG1, CSA C390		Hot	1 time		
			Paint	Munsell No.	7.5BG6/1.5	

ACCESSORIES	
*	B.T.D.(Pt 100 Ω at 0°C,Single) : 2EA/Motor
*	W.T.D.(Pt 100 Ω at 0°C) : 2EA/Ph.
*	Space Heater : 1EA/Motor

SPARE PARTS	

SUBMITTAL DRAWING			
Outline Dimension Drawing	Motor Weight(Approx.)		
B3	LM-I0511B3P7001	4850 lb.	

REMARK				
1. Premium efficiency according to NEMA MG1				
2. Inverter Duty @ 1.0 Service Factor & F Temperature rise				
-. 10:1 VT (20:1 VT at 50% load)				
-. 10:1 CT				
-. CHp up to 1.5 times base speed, NEMA MG1 Part31				
3. NDE side : Insulated bearing				
4. CSA Certification				
-. Class I, Division 2, Group A, B, C & D; Temp code : T3				
-. Class II, Division 2 Group F & G; Temp code : T3				
5. Shaft material : AISI4140				

Date	DSND	CHKD	CHKD	APPD
2024-09-22	E.J.LEE	I.K. Kim	R.G. Kim	S.W. Kim

[Note] Others not mentioned in this data sheet shall be in accordance with maker standard.
 Above technical data are only design values and shall be guaranteed with tolerance of applicable standard.
 Inspection and performance test shall be done according to maker standard, if not mentioned.
 * In case of Inverter-Fed Motor, performance data is based on sine wave tests. It may be different from test data of Inverter combined motor.
 ** Data is based on rated voltage & frequency and is expressed as a percentage of full-load value.

1		2		3		4	
REV	DATE	CONTENTS		REVD BY	CHKD BY	CHKD BY	APPD BY

4.72

CROWN TRITON
Premium Efficiency AC 3 Phase Motor

500HP 6P 460V	Cat. No. IEEE500-12-5011-IBBRSRSH		
Model LATER	INS. Class F	Amps 584.9	
Type PJP	Duty CONT	Code G	Amb. 40°C
Frame 5011	Encl. TEFC	S.F. 1.15	RPM 1185
Bearing	Drive NU324	S.F.1.00 (10:1 C.T., 20:1 V.T., NEMA-MG1 Part31)	
	Opp. 6320C3-INS.	NEMA Nom. Eff. 95.8%	3/4 Eff. 94.8%
Usable at	50Hz 420HP 380V 594.73A 985rpm S.F.: 1.0 Eff.: 95.8% Code: G		
	50Hz 420HP 400/415V 515.87/571.74A 986/987rpm S.F.: 1.0 Eff.: 95.8/95.81% Code: G/J		
CSA Certified for	CLASS I, Div. 2, Gr. A, B, C & D	CLASS II, Div. 2, Gr. F & G	Temp. Code (sine wave)
	CLASS I, Zone 2, Gr. IIA, IIB, & IIC		Frame L440FR - 500FR
			Amb. 40°C T3 (200°C)
No. -	Date -	Weight 4850 lb	Amb. 55°C T3 (200°C)

IEEE Std 841-2021
4M-136054

MARINE DUTY IEEE45
Made in Korea H1

2.36

APPD BY	S.Y.KIM	UNIT	INCH	SUBJECT	CSA Class I, Division2 IEEE841 (XL)	DWG SIZE
CHKD BY	I.K.KIM	SCALE	NONE	TITLE	NAMEPLATE DRAWING	A4 (1:1)
CHKD BY	R.G.KIM	PROJEC'N	3rd Angle			
DSND BY	S.H.LEE	DATE	2024.06.07			
				REF. NO	4M-136054	Sheet No. of
				DWG NO	NP-IEEE500-12-5011-IBBRSRSH	Revision No. 0



PERFORMANCE CURVE

CURVE NO.
PC-IEEE500-12-5011-IBBRSRSH

Type :	PJP
Full Load Torque :	2229.4 lb.ft
Load moment of Inertia (J) :	4666.000 lb.ft ²
Motor moment of Inertia (J) :	272.448 lb.ft ²

375kW 500HP	6 P	60 Hz
Speed at Full Load :		1185 RPM
Rated Voltage	575V	460V 230V
Full Load Current	467.9A	584.9A 1169.8A

SPEED VS TORQUE & CURRENT CURVE

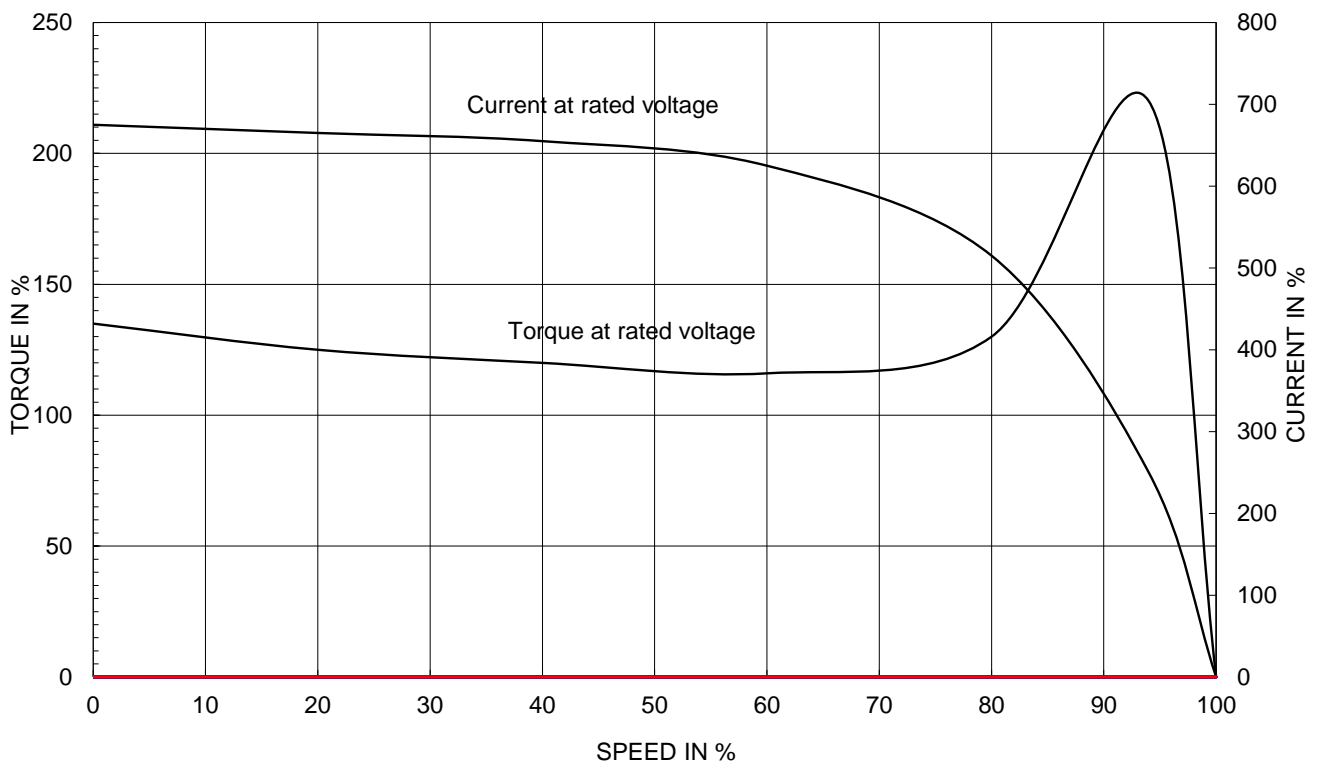

OUTPUT VS EFF., P.F & CURRENT CURVE

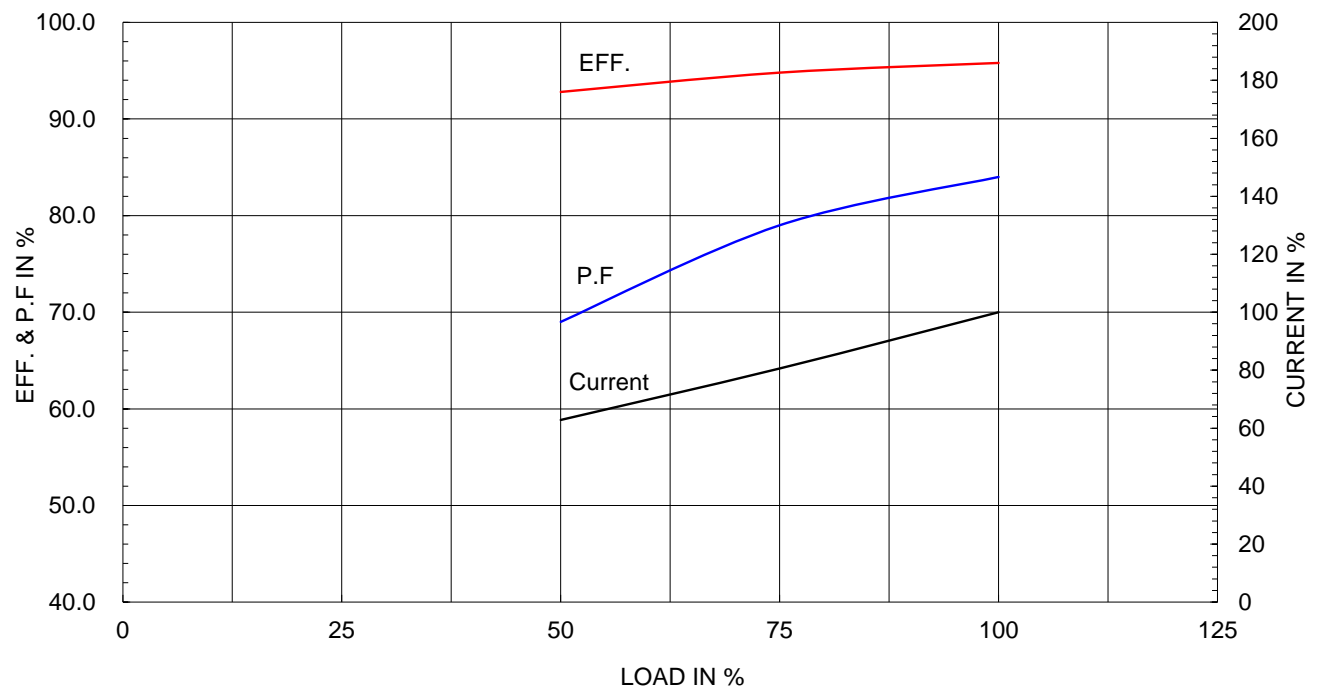

▽	50S	REV	DATE	CONTENTS	REVD BY	CHKD BY	CHKD BY	APPD BY
▽▽	12.5S							
▽▽▽	3.2S							
▽▽▽▽	0.4S							

IEEE841

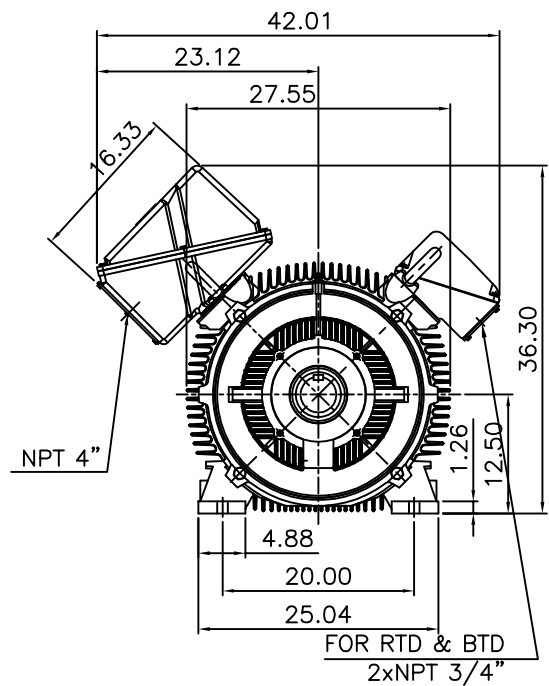
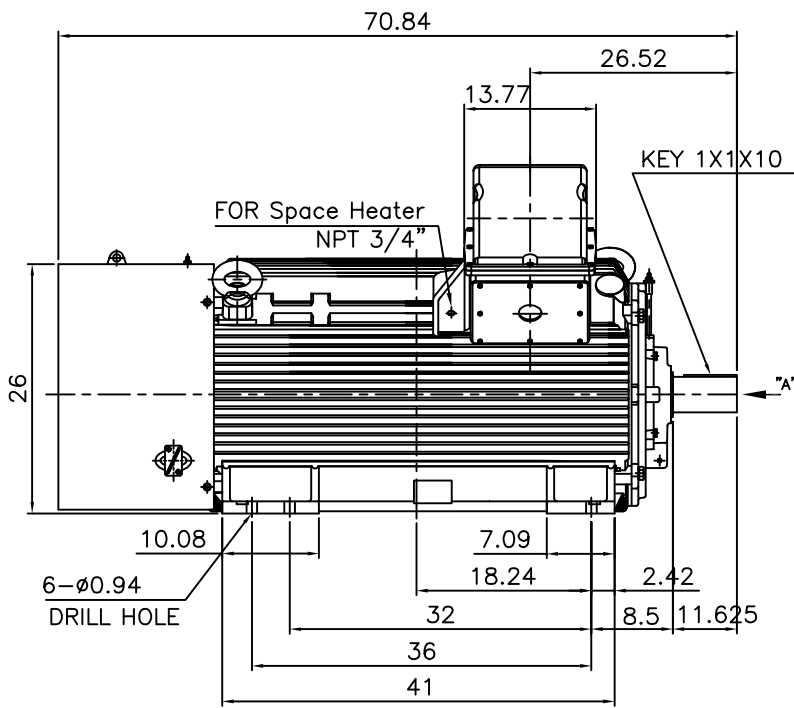

NOTE

1.TOLERANCE :

CENTER HEIGHT	12.5	+0.000	-0.060
SHAFT DIAMETER	ø3.875	+0.000	-0.001
KEYWAY WIDTH	1	+0.003	-0.000

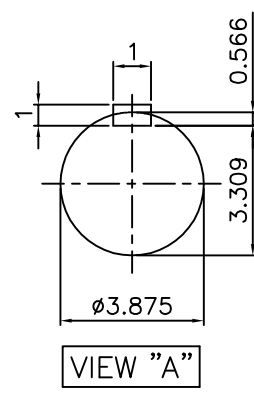

APPD BY	S.Y.KIM	UNIT	INCH	SUBJECT	Fr.5010/5011	DWG SIZE	A4 (1:20)
CHKD BY	O.J.KIM	SCALE	1/20			TITLE	OUTLINE
CHKD BY	R.G.KIM	PROJEC'N	3각법(3rd Angle)	REF. NO		Sheet No.	of
DSND BY	H.K.LEE	DATE	2021-04-27	DWG NO	LM-I0511B3P7001	Revision No.	0



**Cls. I&II, Div. 2
IEEE 841**



SEC. "A" - "A"

REV	DATE	CONTENTS	REVD BY	CHKD BY	CHKD BY	APPD BY

APPD BY	S.Y.KIM	UNIT	inch(mm)	SUBJECT	FR. L440 (CAST IRON)	DWG SIZE
CHKD BY		SCALE	1/3.5	TITLE	MAIN TERMINAL BOX ASS'Y	A3 (1:3.5)
CHKD BY	R.G.KIM	PROJEC'N	3rd Angle			
DSND BY	최승희	DATE	2023-10-19			
				REF. NO		Sheet No. of
				DWG NO	3M-248452	Revision No. 0

Cls. I&II, Div. 2 IEEE 841

본 도면은 HD현대일렉트릭(주) 재산이며
허가없이 복사할 수 없음 (취급주의)

THIS DRAWING IS PROPRIETARY TO HYUNDAI ELECTRIC. NO PART OF THIS DRAWING
MAY BE REPRODUCED WITHOUT THE PERMISSION OF HYUNDAI ELECTRIC.



REV	DATE	CONTENTS	REVD BY	CHKD BY	CHKD BY	APPD BY

APPD BY	S.Y.KIM	UNIT	inch(mm)	SUBJECT	FR.360 (CAST IRON)	DWG SIZE	A3 (1:2.2)
CHKD BY		SCALE	1/1	TITLE	AUX. TERMINAL BOX ASS'Y	REF. NO	Sheet No. of
CHKD BY	R.G.KIM	PROJEC'N	3rd Angle	DSND BY		네슬렉	DATE
				DWG NO	3M-165277	Revision No. 0	

**Cls. I&II, Div. 2
IEEE 841**

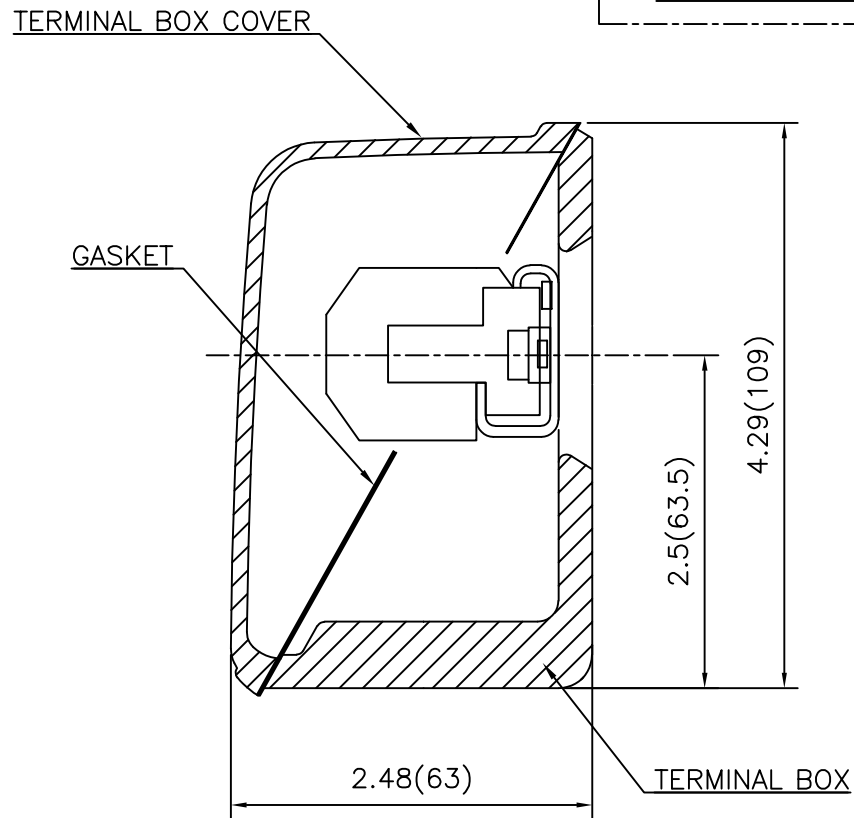
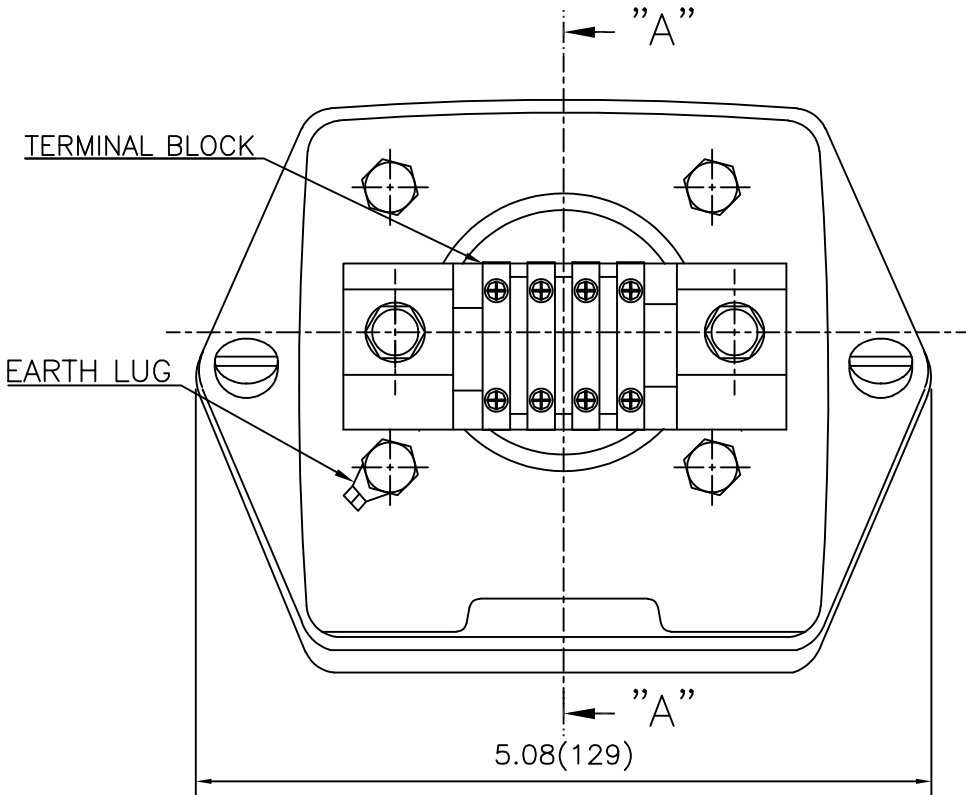

REV	DATE	CONTENTS	REVD BY	CHKD BY	CHKD BY	APPD BY

APPD BY	S.Y.KIM	UNIT	inch(mm)	SUBJECT	FR.180 (CAST IRON)	DWG SIZE	A3 (1:1.1)
CHKD BY		SCALE	1/1	TITLE	SUB. TERMINAL BOX ASS'Y		
CHKD BY	R.G.KIM	PROJEC'N	3rd Angle	REF. NO		Sheet No.	of
DSND BY	박승희	DATE	2024-01-18	DWG NO	3M-165278	Revision No.	0

