

Customer :  
Project Name :  
Project No. :  
Revision No. :

# SPECIFICATION for INDUCTION MOTOR



0		For Bidding			
No.	DATE	DESCRIPTION	PREPARED BY	CHECKED BY	APPROVED BY



# AC INDUCTION MOTOR DATA SHEET

## Explosion Proof type

Catalog No.	IXHHI20-36-256TC	Item No.		Rev. No.	[ ]
Project Name		Project No.		Quantity	sets

GENERAL SPECIFICATION			PERFORMANCE DATA			
Frame Size	256TC		Rated Output	15 kW		20 HP
Type	XJP		Number of Poles	2		
Enclosure(Protection)	Totally Enclosed	/ IP55	Rotor Type	Squirrel Cage		
Method of Cooling	IC411(FC)		Starting Method*	D.O.L		
Rated Frequency	60 Hz		Rated Voltage	575 V	460 V	230 V
Number of Phases	3		Current	Full Load	18.6 A	23.2 A
Insulation Class	F			Locked-rotor**	740 %	740 %
Temp. Rise at full load (by resistance method)			Efficiency			
at 1.0 S.F	80 deg. C		50% Load		88.0 %	
Motor Location	<input type="checkbox"/> Indoor <input type="checkbox"/> Outdoor		75% Load		90.0 %	
Altitude	Less than 1,000 meter		100% Load		91.0 %	
Relative Humidity	Less than 80 %		Power Factor(p.u)			
Ambient Temp.	40 deg. C (Max.)		50% Load		0.740	
Duty Type	Continuous ( S1 )		75% Load		0.840	
Service Factor	1.15		100% Load		0.890	
Mounting	B35		Speed at Full Load	3550 r.p.m		
Bearing	Type	Anti-Friction	Torque			
	DE/N-DE	6309ZC3 / 6309ZC3	Full Load		29.8 lb.ft	
	Lubricant	Grease(Polyrex-EM)	Locked-rotor**		150 %	
External Thrust	Not applicable		Breakdown**		250 %	
Coupling Method	<input checked="" type="checkbox"/> Direct <input type="checkbox"/> V-belt		Moment of Inertia (J)			
Shaft Extension	Single		Load(Max.)		21.594 lb.ft2	
Terminal Box	Main	Cast Iron	Motor		1.163 lb.ft2	
	Aux.	No	Sound Pressure Level (No-load & mean value at 1m from motor)			
	Location	Refer to Outline Drawing			79 dB(A)	
Application			Vibration			
Area classification	Hazardous				0.0 mm/sec (peak)	
Type of Ex-Protection	Class I&II, Division 1		Permissible number of consecutive starts		Cold 0 times	
Applicable Standard	NEMA MG1, CSA C390, UL674		Hot		0 times	
	Paint	Munsell No.	4.0PB5.4/5.5(VL-451)			

### ACCESSORIES

\*. W.T.D.(Thermostat, 145°C) : 1EA/Ph.

### SPARE PARTS

### SUBMITTAL DRAWING

Outline Dimension Drawing		Motor Weight(Approx.)	
B35	LM-U0256C4TL001	300 lb.	

### REMARK

- Premium efficiency according to NEMA MG1
- Inverter Duty @ 1.0 Service Factor & Ambient max 45°C
  - 4:1 CT (10:1 CT at 1hour Duty)
  - 10:1 VT (20:1 VT at 50% load)
  - CHP up to 1.5 times base speed, NEMA MG1 Part31
- Class I, Division 1, Group C&D
  - Temp.Code(Sine wave) : T2D at 40°C Amb./T2C at 55°C Amb. T4 with Winding Temperature Detector
- Class II, Division 1, Group F&G
  - Temp.Code(Sine wave) : T3B

Date	DSND	CHKD	CHKD	APPD
2024-08-08	S.H. Lee	I.K. Kim	R.G. Kim	S.W. Kim

[Note] Others not mentioned in this data sheet shall be in accordance with maker standard.  
 Above technical data are only design values and shall be guaranteed with tolerance of applicable standard.  
 Inspection and performance test shall be done according to maker standard, if not mentioned.  
 \* In case of Inverter-Fed Motor, performance data is based on sine wave tests. It may be different from test data of Inverter combined motor.  
 \*\* Data is based on rated voltage & frequency and is expressed as a percentage of full-load value.

1	2	3	4
REV	DATE	CONTENTS	REVD BY

4.72

**CROWN TRITON**  
Premium Efficiency AC 3 Phase Motor

**Explosion Proof**





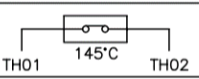

20HP	2P	230/460V	Cat. No. IXHHI20-36-256TC	Amps	46.5/23.2	
Model	LATER		INS. Class F HD-F1	Hertz	60Hz	
Type	XJP	Duty	CONT	Code	H	
Frame	256TC	Encl.	TEFC	S.F. 1.15	on sine wave power	
Bearing	Drive	6309ZC3	S.F. 1.00	on PWM or IGBT power	NEMA Design	
	Opp.	6309ZC3	RPM	3550	Amb.	
Usable at	50Hz 15HP 380V 23.5A 2955rpm S.F.: 1.0 Eff.: 89.4% Code: J					
	50Hz 15HP 400/415V 22.7/22.4A 2960/2960rpm S.F.: 1.0 Eff.: 89.4/89.4% Code: K/L					
UL Certified for	Class I, Div. 1, Group C&D / Class I, Zone 1, Group II A & II B			Temp. Code T4 With Thermostat	T2D at 40°C Amb. / T2C at 55°C Amb.	
	10:1VT(20:1 at 50% load) 4:1CT(10:1 1hour duty at lowest RPM)					
No.	-		Date	-		
4M-136066 (NEMA 250~280Fr.)			Made in Korea H1		Weight	
					300 lb	

2.36

APPD BY	S.Y.KIM	UNIT	INCH	SUBJECT	UL Class I, Division1 (IXHHI)	DWG SIZE
CHKD BY	I.K.KIM	SCALE	NONE			A4 ( 1:1 )
CHKD BY	R.G.KIM	PROJEC'N	3rd Angle	TITLE NAMEPLATE DRAWING		
DSND BY	S.H.LEE	DATE	2024.06.07			



REF. NO	4M-136066	Sheet No.	of
DWG NO	NP-IXHHI20-36-256TC	Revision No.	0

Type :	XJP
Full Load Torque :	29.8 lb.ft
Load moment of Inertia (J) :	21.594 lb.ft2
Motor moment of Inertia (J) :	1.163 lb.ft2

15kW	20HP	2 P	60 Hz
Speed at Full Load :			3550 RPM
Rated Voltage	575V	460V	230V
Full Load Current	18.6A	23.2A	46.5A

SPEED VS TORQUE & CURRENT CURVE

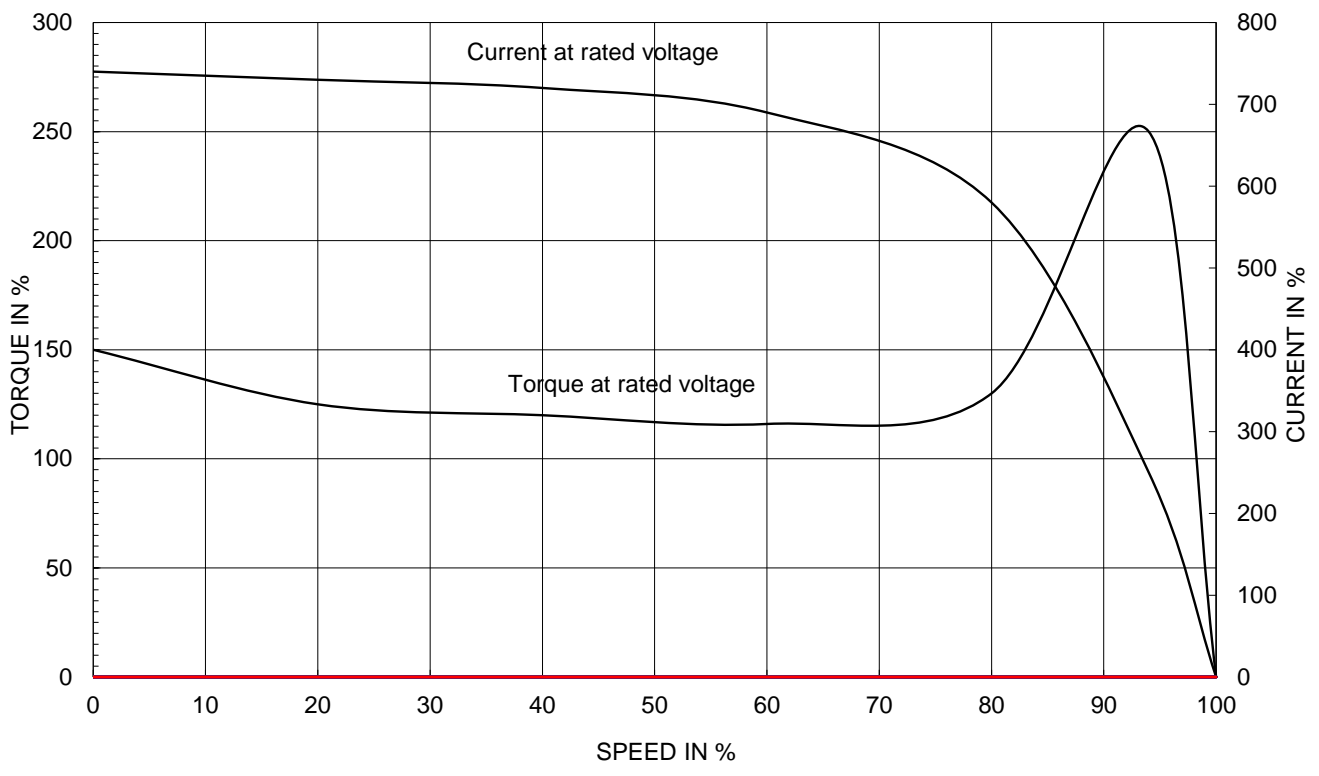

OUTPUT VS EFF., P.F & CURRENT CURVE

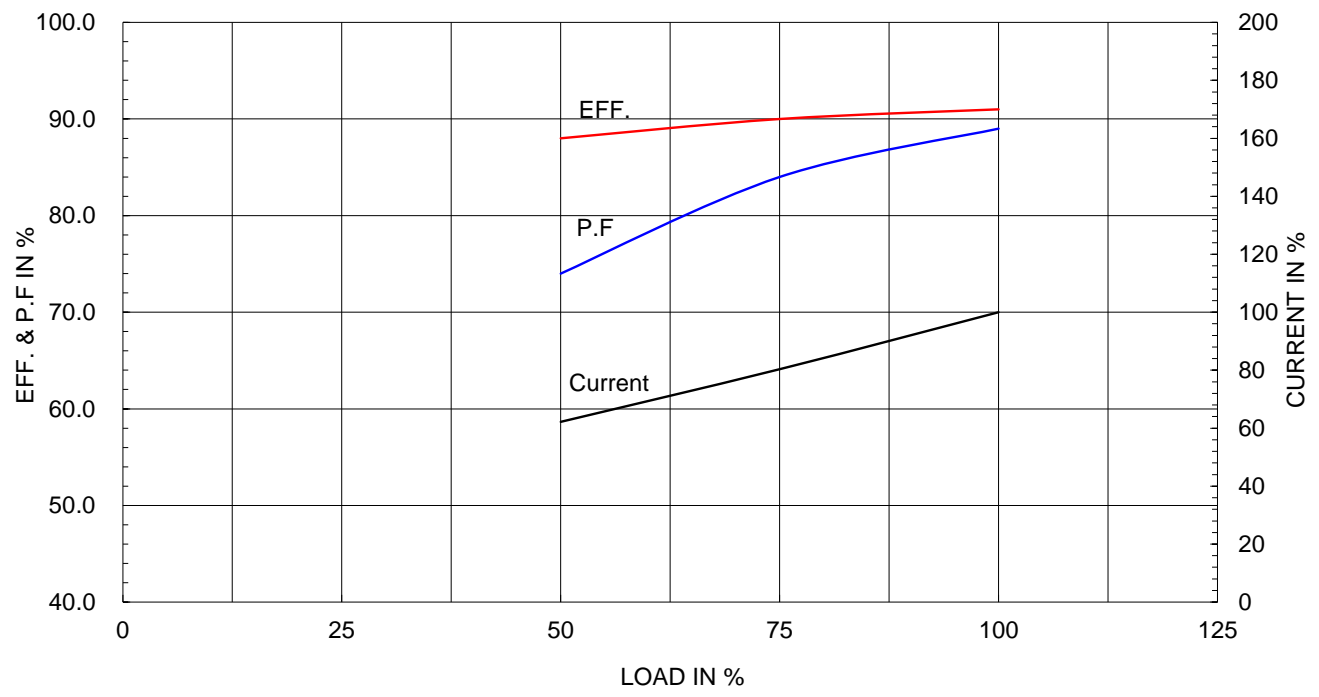

▽	50S	REV	DATE	CONTENTS	REVD BY	CHKD BY	CHKD BY	APPD BY
▽▽	12.5S							
▽▽▽	3.2S							
▽▽▽▽	0.4S							

**Class I Division 1**

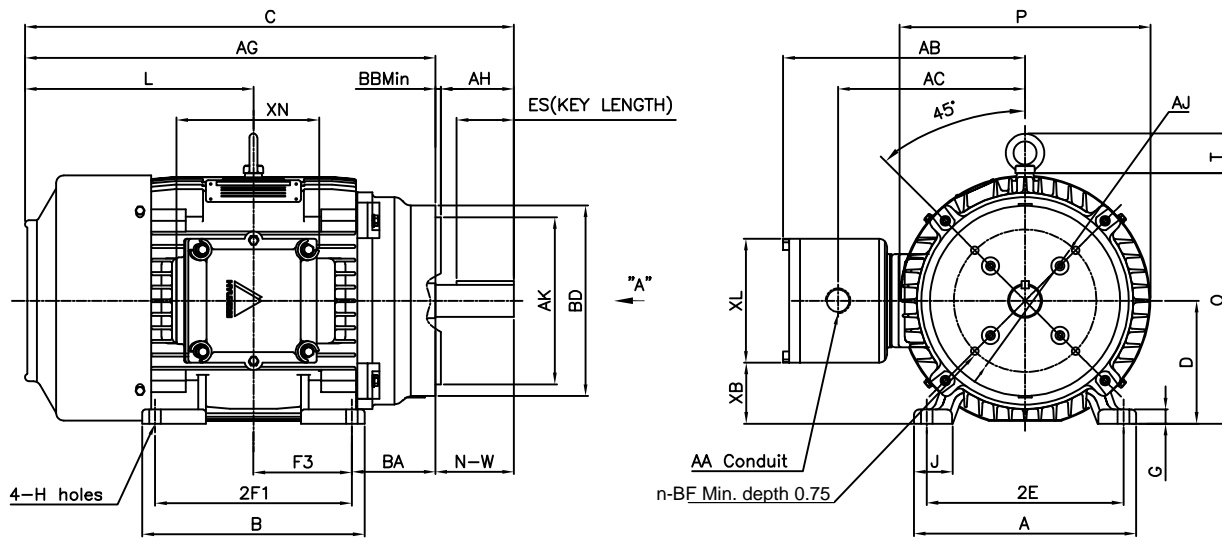

DIMENSIONS

MOUNTING									CONDUIT BOX						APPROX. WGT.(LB)
A	B	2E	2F1	2F2	F3	G	J	H	AA	AB	AC	XB	XL	XN	
11.30	11.30	10.00	10.00	-	5.00	0.72	1.93	0.53	1.25	12.01	9.51	3.15	6.63	7.32	300

OVERALL								SHAFT					KEY THK.	BEARING	
AG	BA	C	D	L	O	P	T	U	N-W	KEYWAY		DRIVE END		OPP. DRIVE END	
										R	ES	S			
20.86	4.25	24.86	6.25	11.61	12.75	12.76	2.01	1.625	4.00	1.416	2.91	0.375	0.375	6309ZC3	6309ZC3

C-FACE						
AJ	AK	BD	BB	BF	n	AH
7.25	8.50	9.68	0.25	1/2-13	4	3.75

NOTE

- 1.Dimension "D" tolerance : +0.00inch ~ -0.03inch (143TC-365TC) : +0.000inch ~ -0.06inch (404TC-449TC)
- 2.Dimension "U" tolerance : +0.000inch ~ -0.0005inch (143TC-215TC): +0.000inch ~ -0.001inch (254TC-449TC)
- 3.Dimension "R" tolerance : +0.000inch ~ - 0.015inch
- 4.Dimension "AK" tolerance : +0.000inch ~ -0.003inch (143TC-286TC): +0.000inch ~ -0.005inch (324TC-449TC)

APPD BY	S.Y.KIM	UNIT	inch	SUBJECT	NEMA 256TC(KIT)	DWG SIZE	A4 ( 1:10 )
CHKD BY	R.G.KIM	SCALE	1/10	TITLE	OUTLINE	REF. NO	Sheet No. of
CHKD BY		PROJEC'N	3rd Angle				
DSND BY	J.H.JEON	DATE	2021-04-15				
				DWG NO	LM-U0256C4TL001	Revision No.	0

# Cls. I Div. 1

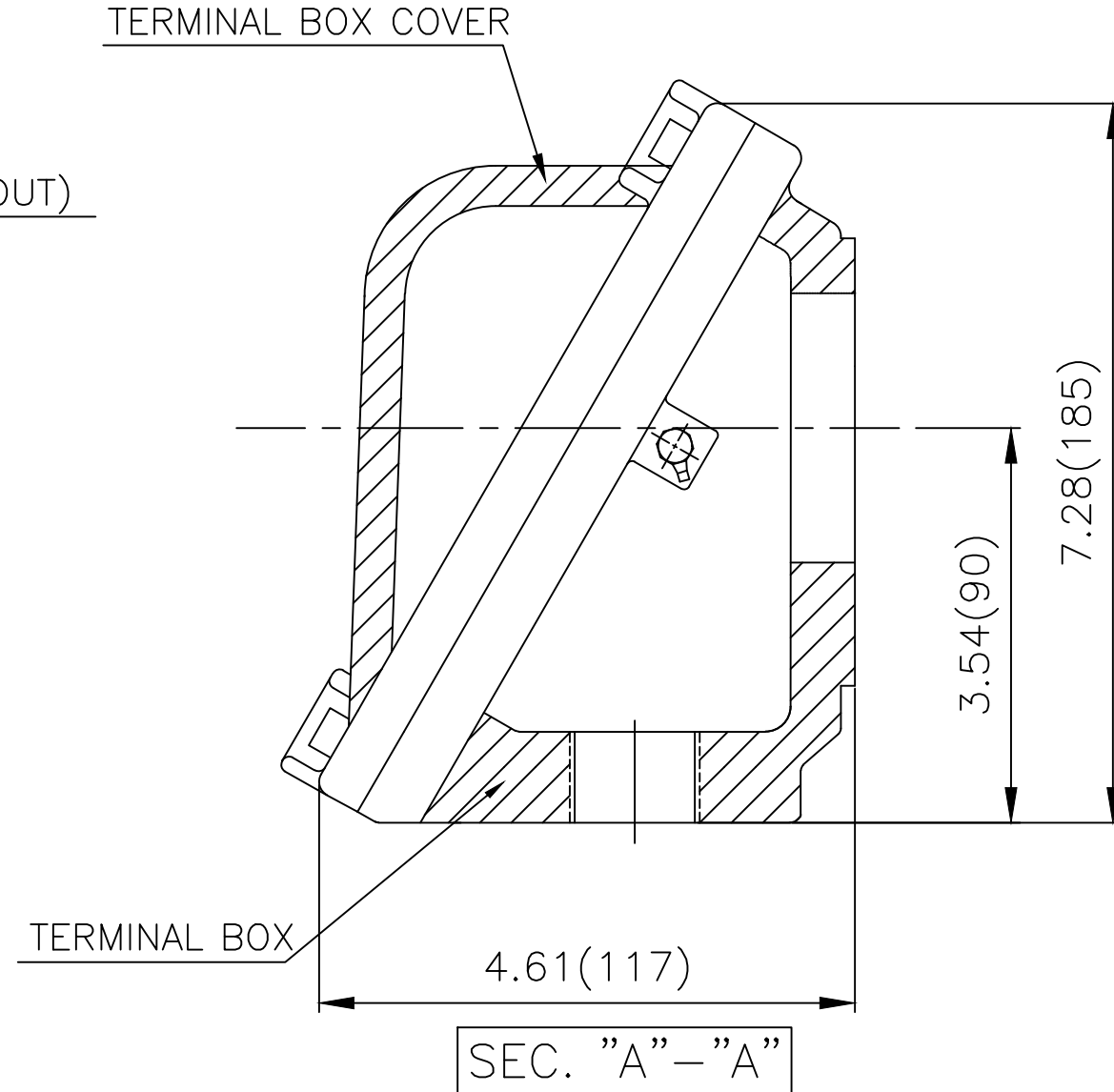
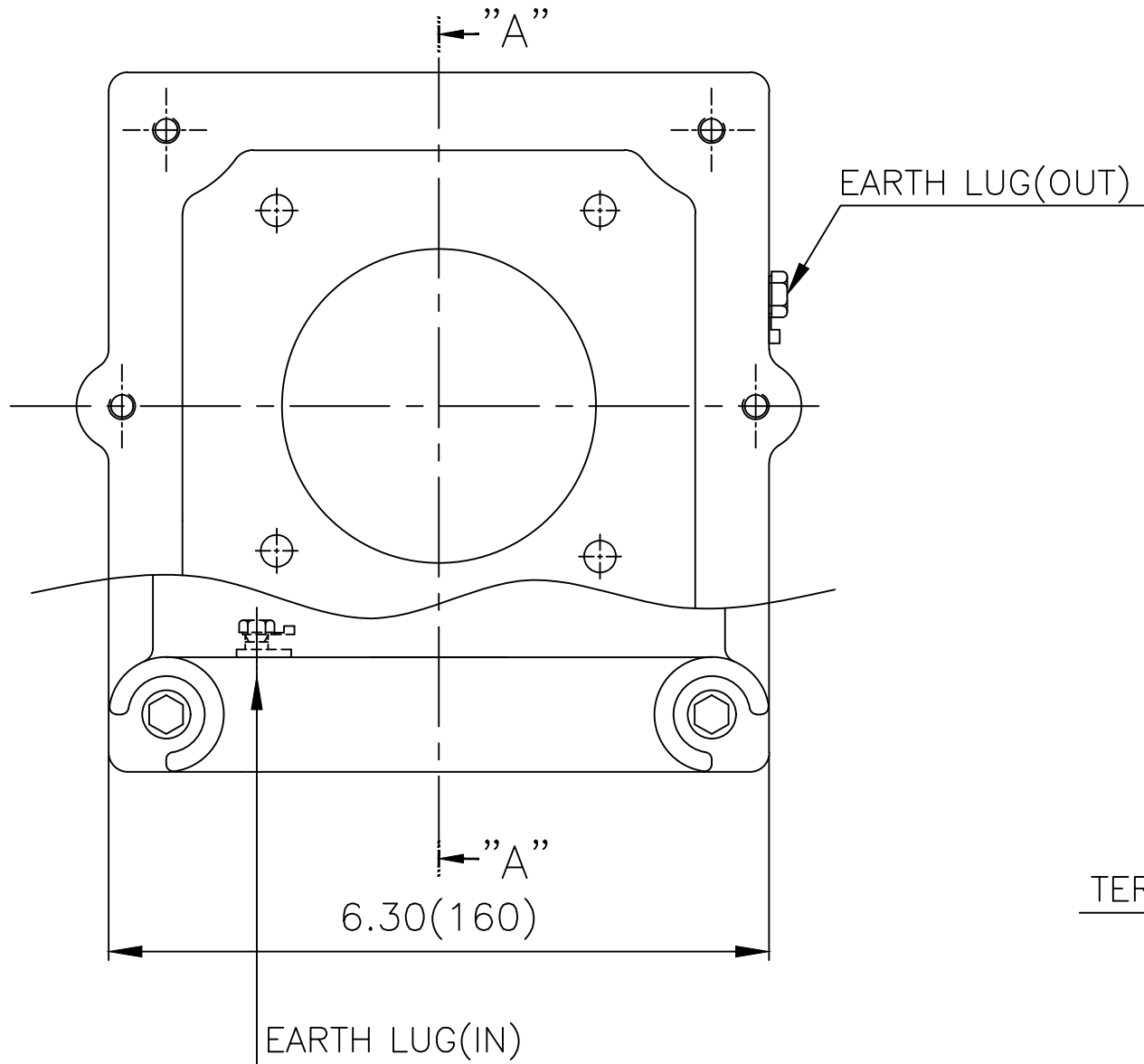

▽	50S
▽▽	12.5S
▽▽▽	3.2S
▽▽▽▽	0.4S

REV	DATE	CONTENTS	REVD BY	CHKD BY	CHKD BY	APPD BY

일반가공공차		일반제관공차	
1-4	±0.1	6-30	±0.5
4-18	±0.2	30-120	±0.8
18-63	±0.3	120-315	±1.2
63-250	±0.5	315-1000	±2.0
250-	±0.8	1000-	±3.0

Q'TY	DESCRIPTION	MATERIAL	DIMENSION	WEIGHT	PART NO.	REMARK	NO.
APPD BY	S.Y.KIM	UNIT	inch(mm)	SUBJECT	NEMA FR. 250~280(CAST IRON)	DWG SIZE	A3 (1:1.5)
CHKD BY	R.G.KIM	SCALE	1/1.5	TITLE	MAIN TERMINAL BOX ASS'Y		
CHKD BY		PROJEC'N	3rd Angle	REF. NO		Sheet No.	of
DSND BY	김은진	DATE	2023-11-08	DWG NO	3M-248637	Revision No.	0

