

Customer :
 Project Name :
 Project No. :
 Revision No. :

SPECIFICATION for INDUCTION MOTOR



| 0 | | For Bidding | | | |
|-----|------|-------------|-------------|------------|-------------|
| No. | DATE | DESCRIPTION | PREPARED BY | CHECKED BY | APPROVED BY |



AC INDUCTION MOTOR DATA SHEET

IEEE841 TYPE

| | | | | |
|--------------|-----------------------|-------------|------------------------------------|----------|
| Catalog No. | IEEE350-18-L449T-IBSH | Item No. | Rev. No. | [] |
| Project Name | | Project No. | Quantity sets | |

| GENERAL SPECIFICATION | | | PERFORMANCE DATA | | | |
|--|--|--|------------------|--|---------------|----------------|
| Frame Size | L449T | Rated Output | 260 kW | | 350 HP | |
| Type | PJP | Number of Poles | 4 | | | |
| Enclosure(Protection) | Totally Enclosed / IP55 | Rotor Type | Squirrel Cage | | | |
| Method of Cooling | IC411(FC) | Starting Method* | D.O.L | | | |
| Rated Frequency | 60 Hz | Rated Voltage | 575 V | 460 V | 230 V | |
| Number of Phases | 3 | Current | Full Load | 308.4 A | 385.5 A | 771.0 A |
| Insulation Class | F | | Locked-rotor** | 715 % | 715 % | 715 % |
| Temp. Rise at full load (by resistance method) | | Efficiency | | | | |
| at 1.0 S.F | 80 deg. C | 50% Load | | 93.2 % | | |
| Motor Location | <input type="checkbox"/> Indoor <input type="checkbox"/> Outdoor | 75% Load | | 95.2 % | | |
| Altitude | Less than 1,000 meter | 100% Load | | 96.2 % | | |
| Relative Humidity | Less than 80 % | Power Factor(p.u) | | | | |
| Ambient Temp. | 40 deg. C (Max.) | 50% Load | | 0.730 | | |
| Duty Type | Continuous (S1) | 75% Load | | 0.830 | | |
| Service Factor | 1.15 | 100% Load | | 0.880 | | |
| Mounting | B3 | Speed at Full Load | | 1785 r.p.m | | |
| Bearing | Type | Anti-Friction | | Torque | | |
| | DE/N-DE | NU322 / 6318C3-INS. | | Full Load | 1,026.2 lb.ft | |
| | Lubricant | Grease(Polyrex-EM) | | Locked-rotor** | 135 % | |
| External Thrust | Not applicable | | Breakdown** | 225 % | | |
| Coupling Method | <input type="checkbox"/> Direct <input type="checkbox"/> V-belt | Moment of Inertia (J) | | | | |
| Shaft Extension | Single | Load(Max.) | | 1,370.000 lb.ft2 | | |
| Terminal Box | Main | Cast Iron | | Motor | | 118.425 lb.ft2 |
| | Aux. | Yes | | Sound Pressure Level (No-load & mean value at 1m from motor) | | |
| Location | Refer to Outline Drawing | | 85 dB(A) | | | |
| Application | | Vibration | | 3.8 mm/sec (peak) | | |
| Area classification | Hazardous | Permissible number of consecutive starts | | Cold | 2 times | |
| Type of Ex-Protection | Class I&II, Division 2 | | | Hot | 1 time | |
| Applicable Standard | IEEE841, NEMA MG1, CSA C390 | Paint | Munsell No. | 7.5BG6/1.5 | | |

| ACCESSORIES |
|-----------------------------|
| *. Space Heater : 1EA/Motor |

| SUBMITTAL DRAWING | | |
|---------------------------|-----------------------|----------|
| Outline Dimension Drawing | Motor Weight(Approx.) | |
| B3 | LM-I044XB3UE001 | 3090 lb. |

REMARK

1. Premium efficiency according to NEMA MG1
2. Inverter Duty @ 1.0 Service Factor & F Temperature rise
 - . 10:1 VT (20:1 VT at 50% load)
 - . 10:1 CT
 - . CHp up to 1.5 times base speed, NEMA MG1 Part31
3. NDE side : Insulated bearing
4. CSA Certification
 - . Class I, Division 2, Group A, B, C & D; Temp code : T3
 - . Class II, Division 2 Group F & G; Temp code : T3
5. Shaft material : AISI4140

| | | | | |
|------------|---------|----------|----------|----------|
| Date | DSND | CHKD | CHKD | APPD |
| 2024-09-22 | E.J.LEE | I.K. Kim | R.G. Kim | S.W. Kim |

| SPARE PARTS |
|-------------|
| |

[Note] Others not mentioned in this data sheet shall be in accordance with maker standard.
 Above technical data are only design values and shall be guaranteed with tolerance of applicable standard.
 Inspection and performance test shall be done according to maker standard, if not mentioned.
 * In case of Inverter-Fed Motor, performance data is based on sine wave tests. It may be different from test data of Inverter combined motor.
 ** Data is based on rated voltage & frequency and is expressed as a percentage of full-load value.

본 도면은 HD현대일렉트릭(주) 재산이며
허가없이 복사할 수 없음 (취급주의)

THIS DRAWING IS PROPRIETARY TO HYUNDAI ELECTRIC. NO PART OF THIS DRAWING
MAYBE REPRODUCED WITHOUT THE PERMISSION OF HYUNDAI ELECTRIC.

| | | | |
|--|--|--|--|
| | | | |
| | | | |
| | | | |
| | | | |

4.72

2.36

CROWN TRITON
Premium Efficiency AC 3 Phase Motor

| | |
|--|--|
| 350HP 4P 460V | Cat. No. IEE350-18-L449T-IBSH |
| Model LATER | INS. Class F |
| Type PJP | Duty CONT |
| Code G | Amb. 40°C |
| Amps 385.5 | Hertz 60Hz |
| Frame L449T | Encl. TEFC |
| S.F. 1.15 | RPM 1785 |
| NEMA Nom. Eff. 96.2% | 3/4 Eff. 95.2% |
| Bearing Drive NU322 | S.F.1.00 (10:1 C.T., 20:1 V.T., NEMA-MG1 Part31) |
| Opp. 6318C3-INS. | NEMA Design B |
| Usable at 50Hz 300HP 380V 404.65A 1485rpm S.F.: 1.0 Eff.: 96% Code: G | |
| Usable at 50Hz 300HP 400/415V 393.36/387.77A 1486/1487rpm S.F.: 1.0 Eff.: 96/96.1% Code: H/J | |
| CSA Certified for CLASS I, Div. 2, Gr. A, B, C & D CLASS I, Zone 2, Gr. IIA, IIB, & IIC | CLASS II, Div. 2, Gr. F & G |
| Temp. Code (sine wave) | Frame L440FR - 500FR |
| Amb. 40°C | T3 (200°C) |
| Amb. 55°C | T3 (200°C) |
| No. - | Date - |
| Weight 3090 lb | |

IEEE Std 841-2021 MARINE DUTY IEE45
 4M-136054 Made in Korea H1

| | | | | | | |
|---------|---------|----------|------------|-------------------|------------------------------------|-----------------------|
| APPD BY | S.Y.KIM | UNIT | INCH | SUBJECT | CSA Class I, Division2 IEE841 (XL) | DWG SIZE |
| CHKD BY | I.K.KIM | SCALE | NONE | | | A4 (1:1) |
| CHKD BY | R.G.KIM | PROJEC'N | 3rd Angle | NAMEPLATE DRAWING | | |
| DSND BY | S.H.LEE | DATE | 2024.06.07 | | | |
| | | | | REF. NO | 4M-136054 | Sheet No. of |
| | | | | DWG NO | NP-IEE350-18-L449T-IBSH | Revision No. 0 |

| | |
|-------------------------------|-----------------|
| Type : | PJP |
| Full Load Torque : | 1026.2 lb.ft |
| Load moment of Inertia (J) : | 1370.000 lb.ft2 |
| Motor moment of Inertia (J) : | 118.425 lb.ft2 |

| | | |
|----------------------|--------|---------------|
| 260kW 350HP | 4 P | 60 Hz |
| Speed at Full Load : | | 1785 RPM |
| Rated Voltage | 575V | 460V 230V |
| Full Load Current | 308.4A | 385.5A 771.0A |

SPEED VS TORQUE & CURRENT CURVE

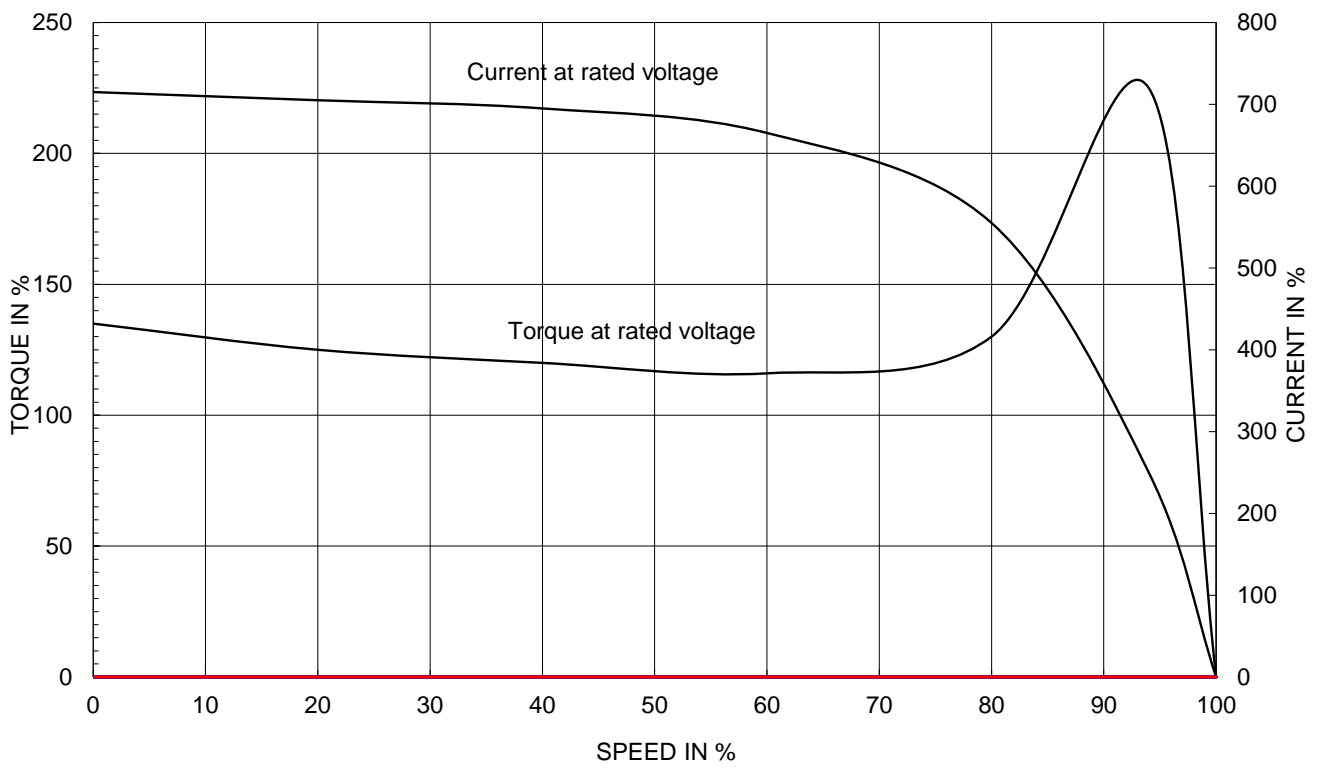

OUTPUT VS EFF., P.F & CURRENT CURVE

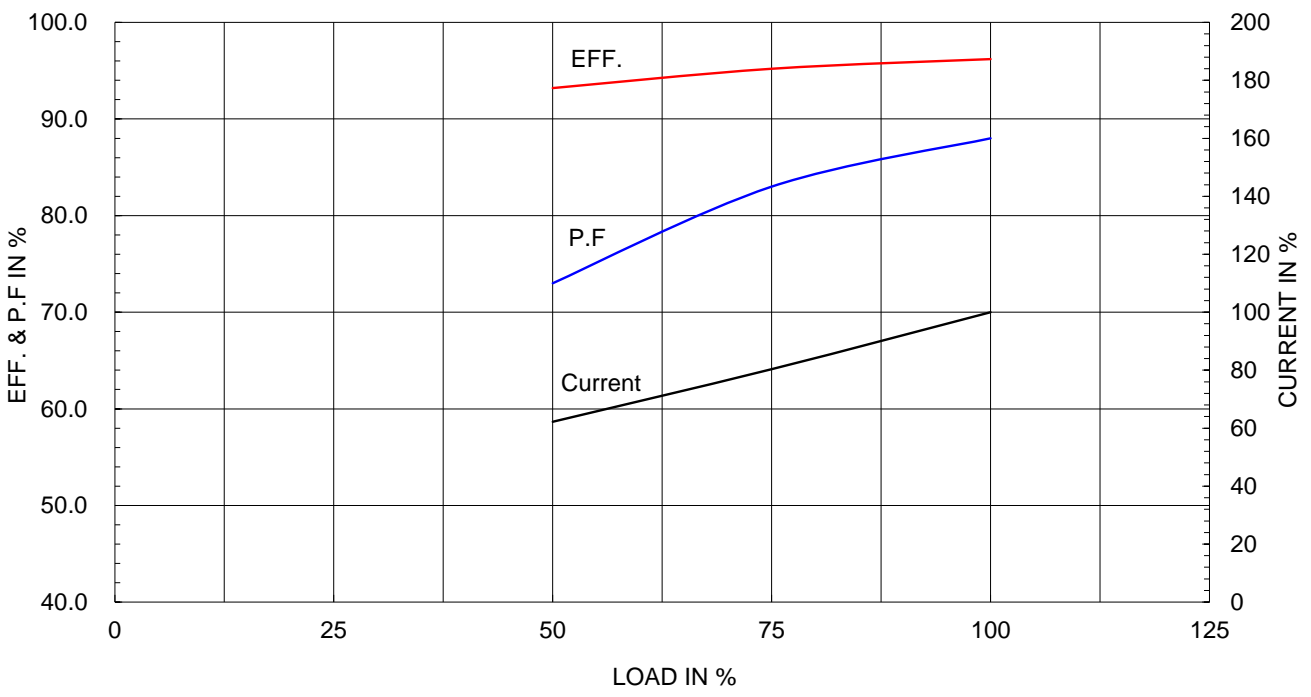

| | | | | | | | | |
|------|-------|-----|------|----------|---------|---------|---------|---------|
| ▽ | 50S | REV | DATE | CONTENTS | REVD BY | CHKD BY | CHKD BY | APPD BY |
| ▽▽ | 12.5S | | | | | | | |
| ▽▽▽ | 3.2S | | | | | | | |
| ▽▽▽▽ | 0.4S | | | | | | | |

IEEE841

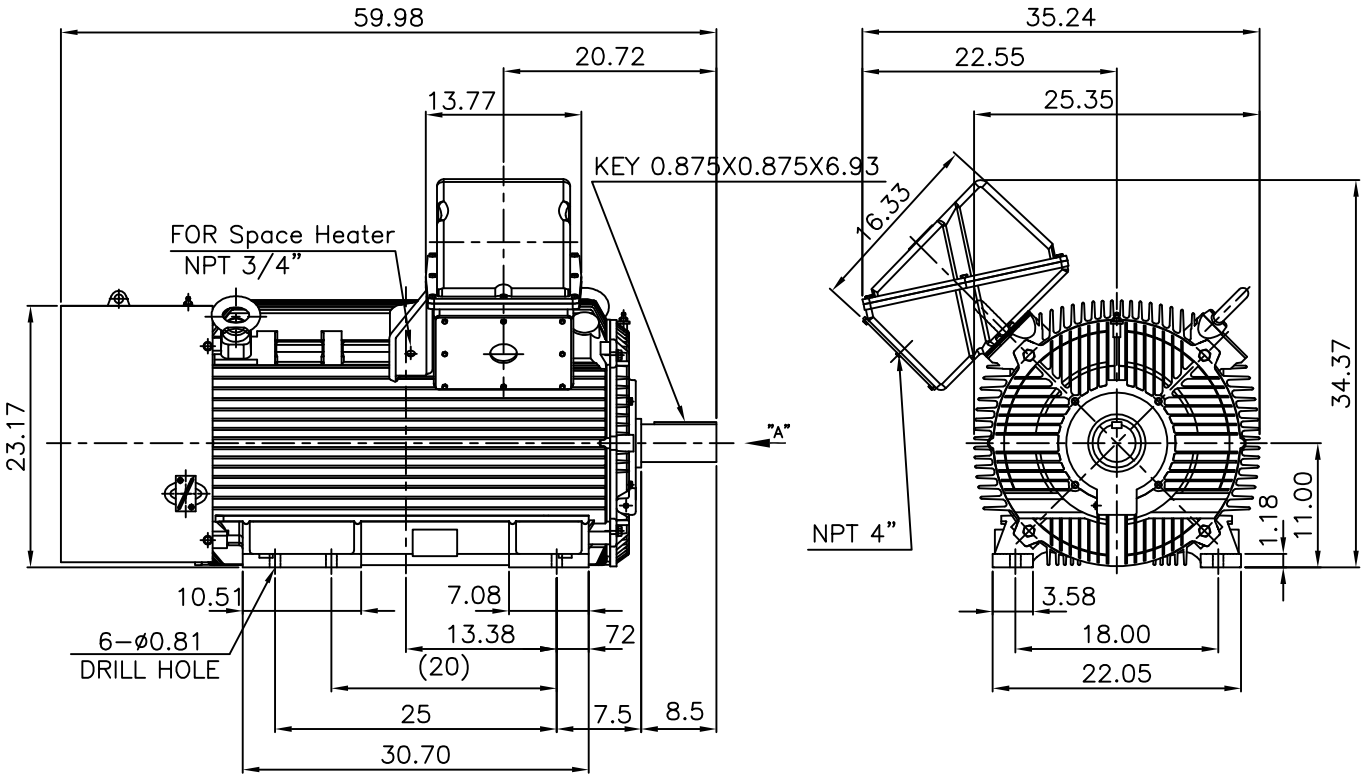

NOTE

1.TOLERANCE :

| | | | |
|----------------|--------|--------|--------|
| CENTER HEIGHT | 11 | +0.000 | -0.060 |
| SHAFT DIAMETER | ø3.375 | +0.000 | -0.001 |
| KEYWAY WIDTH | 0.875 | +0.003 | -0.000 |

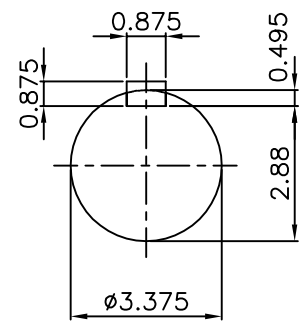

VIEW "A"

| | | | | | | | |
|---------|---------|----------|----------------|---------|-----------------|---|-----------|
| APPD BY | S.Y.KIM | UNIT | INCH | SUBJECT | Fr.L449T | DWG SIZE | A4 (1:18) |
| CHKD BY | O.J.KIM | SCALE | 1/18 | TITLE | OUTLINE | REF. NO. _____ Sheet No. _____ of _____ | |
| CHKD BY | R.G.KIM | PROJEC'N | 3각법(3rd Angle) | | | | |
| DSND BY | H.K.LEE | DATE | 2021-04-27 | | | | |
| | | | | DWG NO | LM-1044XB3UE001 | Revision No. 0 | |

Cls. I&II, Div. 2
IEEE 841

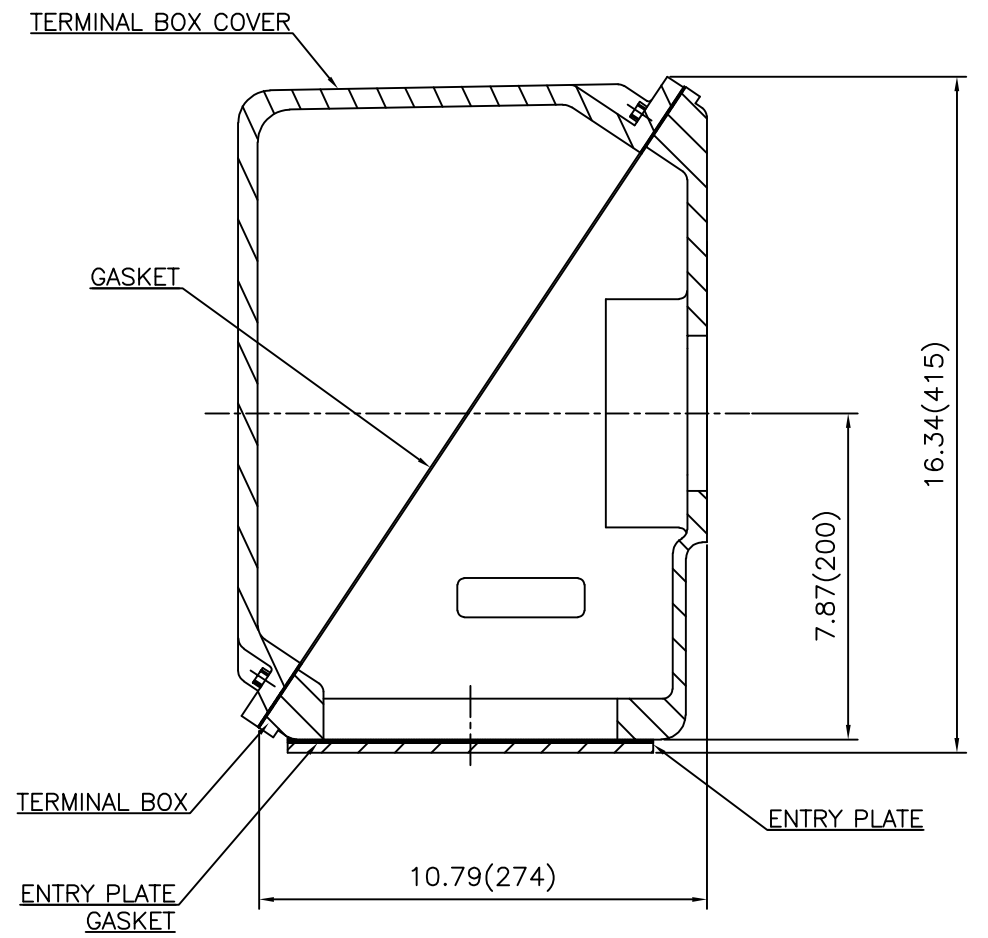
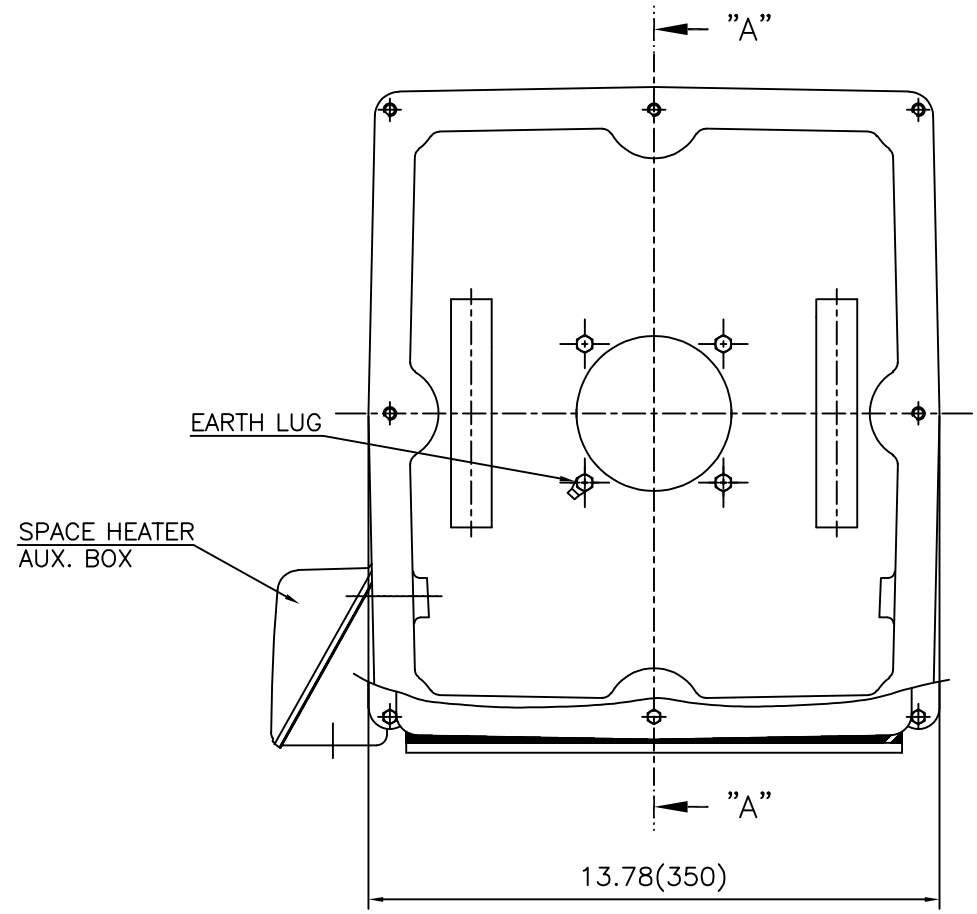

SEC. "A" - "A"

| REV | DATE | CONTENTS | REVD BY | CHKD BY | CHKD BY | APPD BY |
|-----|------|----------|---------|---------|---------|---------|
| | | | | | | |
| | | | | | | |

| | | | | | | |
|---------|---------|----------|------------|---------|-------------------------|----------------|
| APPD BY | S.Y.KIM | UNIT | inch(mm) | SUBJECT | FR. L440 (CAST IRON) | DWG SIZE |
| CHKD BY | | SCALE | 1/3.5 | TITLE | MAIN TERMINAL BOX ASS'Y | A3 (1:3.5) |
| CHKD BY | R.G.KIM | PROJEC'N | 3rd Angle | | | |
| DSND BY | 최승희 | DATE | 2023-10-19 | | | |
| | | | | REF. NO | | Sheet No. of |
| | | | | DWG NO | 3M-248452 | Revision No. 0 |

**Cls. I&II, Div. 2
IEEE 841**



SEC. "A" - "A"

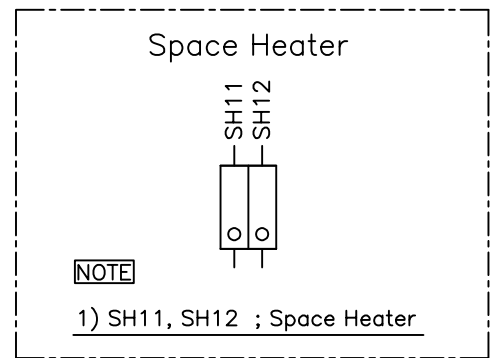

| REV | DATE | CONTENTS | REVD BY | CHKD BY | CHKD BY | APPD BY |
|-----|------|----------|---------|---------|---------|---------|
| | | | | | | |
| | | | | | | |

| | | | | | | | |
|---------|---------|----------|------------|---------|-------------------------|--------------|------------|
| APPD BY | S.Y.KIM | UNIT | inch(mm) | SUBJECT | FR.180 (CAST IRON) | DWG SIZE | A3 (1:1.1) |
| CHKD BY | | SCALE | 1/1 | TITLE | SUB. TERMINAL BOX ASS'Y | | |
| CHKD BY | R.G.KIM | PROJEC'N | 3rd Angle | REF. NO | | Sheet No. | of |
| DSND BY | 배승희 | DATE | 2024-01-18 | DWG NO | 3M-165278 | Revision No. | 0 |

