

Customer :
 Project Name :
 Project No. :
 Revision No. :

SPECIFICATION for INDUCTION MOTOR



0		For Bidding			
No.	DATE	DESCRIPTION	PREPARED BY	CHECKED BY	APPROVED BY



AC INDUCTION MOTOR DATA SHEET

Catalog No.	HSDE300-36-L449TSC-IBSHSP	Item No.		Rev. No.	[]
Project Name		Project No.		Quantity	sets

GENERAL SPECIFICATION			PERFORMANCE DATA			
Frame Size	L449TSC		Rated Output	225 kW 300 HP		
Type	PJP		Number of Poles	2		
Enclosure(Protection)	Totally Enclosed	/	IP55	Rotor Type	Squirrel Cage	
Method of Cooling	IC411(FC)		Starting Method*	D.O.L		
Rated Frequency	60 Hz		Rated Voltage	575 V	460 V	230 V
Number of Phases	3		Current	Full Load	262.0 A	327.5 A 655.1 A
Insulation Class	F			Locked-rotor**	700 %	700 % 700 %
Temp. Rise at full load (by resistance method)			Efficiency			
at 1.0 S.F	80 deg. C		50% Load 92.8 %			
Motor Location	<input type="checkbox"/> Indoor <input type="checkbox"/> Outdoor		75% Load 94.8 %			
Altitude	Less than 1,000 meter		100% Load 95.8 %			
Relative Humidity	Less than 80 %		Power Factor(p.u)			
Ambient Temp.	40 deg. C (Max.)		50% Load 0.750			
Duty Type	Continuous (S1)		75% Load 0.850			
Service Factor	1.15		100% Load 0.900			
Mounting	B35		Speed at Full Load	3570 r.p.m		
Bearing	Type	Anti-Friction		Torque		
	DE/N-DE	6315C3 / 6315C3-INS.		Full Load	444.0 lb.ft	
	Lubricant	Grease(Polyrex-EM)		Locked-rotor**	130 %	
External Thrust	Not applicable		Breakdown**	225 %		
Coupling Method	<input checked="" type="checkbox"/> Direct <input type="checkbox"/> V-belt		Moment of Inertia (J)			
Shaft Extension	Single		Load(Max.) 246.000 lb.ft2			
Terminal Box	Main	Cast Iron		Motor 43.668 lb.ft2		
	Aux.	Yes		Sound Pressure Level (No-load & mean value at 1m from motor)		
	Location	Refer to Outline Drawing		87 dB(A)		
Application			Vibration 3.8 mm/sec (peak)			
Area classification	Hazardous		Permissible number of consecutive starts			
Type of Ex-Protection	Class I&II, Division 2		Cold 2 times			
Applicable Standard	NEMA MG1, CSA C390		Hot 1 time			
			Paint	Munsell No.	4.0PB5.4/5.5(VL-451)	

ACCESSORIES
*. Space Heater : 1EA/Motor

SPARE PARTS
1. Spare Axial Fan (C.W Direction)

SUBMITTAL DRAWING			
Outline Dimension Drawing		Motor Weight(Approx.)	
B35	LM-T044XC4CE001	2990 lb.	

REMARK
1. Premium efficiency according to NEMA MG1
2. Inverter Duty @ 1.0 Service Factor & F Temperature rise
-. 10:1 VT (20:1 VT at 50% load)
-. 10:1 CT
-. CHp up to 1.5 times base speed, NEMA MG1 Part31
3. NDE side : Insulated bearing
4. CSA Certification
-. Class I, Division 2, Group A, B, C & D; Temp code : T3
-. Class II, Division 2 Group F & G; Temp code : T3
5. Uni-directional CCW viewed from drive end.

Date	DSND	CHKD	CHKD	APPD
2024-09-10	S.H. Lee	I.K. Kim	R.G. Kim	S.W. Kim

[Note] Others not mentioned in this data sheet shall be in accordance with maker standard.
 Above technical data are only design values and shall be guaranteed with tolerance of applicable standard.
 Inspection and performance test shall be done according to maker standard, if not mentioned.
 * In case of Inverter-Fed Motor, performance data is based on sine wave tests. It may be different from test data of Inverter combined motor.
 ** Data is based on rated voltage & frequency and is expressed as a percentage of full-load value.

1	2	3	4
REV	DATE	CONTENTS	REVD BY CHKD BY CHKD BY APPD BY

4.72

CROWN TRITON
Premium Efficiency AC 3 Phase Motor







300HP 2P 460V		Cat. No. HSDE300-36-L449TSC-IBSHSP	
Model LATER	INS. Class F	Amps	327.5
Type PJP	Duty CONT	Code G	Amb. 40°C
Frame L449TSC	Encl. TEFC	S.F. 1.15	RPM 3570
Bearing	Drive 6315C3	S.F.1.00 (10:1 C.T., 20:1 V.T., NEMA-MG1 Part31)	
	Opp. 6315C3-INS.	NEMA Nom. Eff.	95.8%
Usable at	50Hz 250HP 380V 334.81A 2970rpm S.F.: 1.0 Eff.: 95.8% Code: G		
	50Hz 250HP 400/415V 321.65/309.99A 2972/2975rpm S.F.: 1.0 Eff.: 95.8/95.81% Code: H/J		
CSA Certified for	CLASS I, Div. 2, Gr. A, B, C & D	CLASS II, Div. 2, Gr. F & G	Temp. Code (sine wave)
	CLASS I, Zone 2, Gr. IIA, IIB, & IIC		Frame L440FR - 500FR
			Amb. 40°C T3 (200°C)
No. -	Date -	Weight	2990 lb

4M-136053
MARINE DUTY IEEE45

Made in Korea H1



2.36

APPD BY	S.Y.KIM	UNIT	INCH	SUBJECT	CSA Class I, Division2 Severe Duty (HSDE ,L449-500)	DWG SIZE
CHKD BY	I.K.KIM	SCALE	NONE			A4 (1:1)
CHKD BY	R.G.KIM	PROJEC'N	3rd Angle	TITLE NAMEPLATE DRAWING		
DSND BY	S.H.LEE	DATE	2024.06.07			
				REF. NO	4M-136053	Sheet No. of
				DWG NO	NP-HSDE300-36-L449TSC-IBSHSP	Revision No. 0



PERFORMANCE CURVE

CURVE NO.

PC-HSDE300-36-L449TSC-IBSHSP

Type :	PJP	
Full Load Torque :	444.0	lb.ft
Load moment of Inertia (J) :	246.000	lb.ft2
Motor moment of Inertia (J) :	43.668	lb.ft2

225kW	300HP	2 P	60 Hz
Speed at Full Load :			3570 RPM
Rated Voltage	575V	460V	230V
Full Load Current	262.0A	327.5A	655.1A

SPEED VS TORQUE & CURRENT CURVE

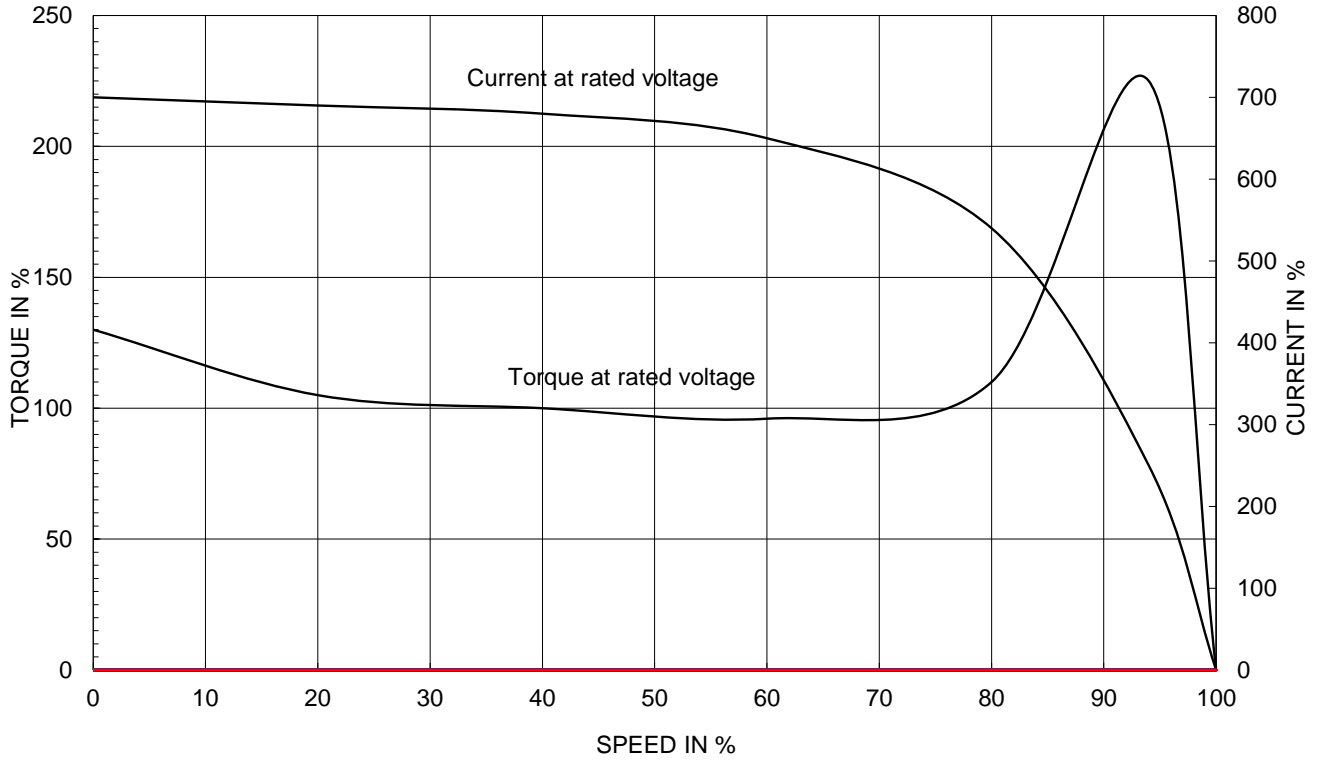

OUTPUT VS EFF., P.F & CURRENT CURVE

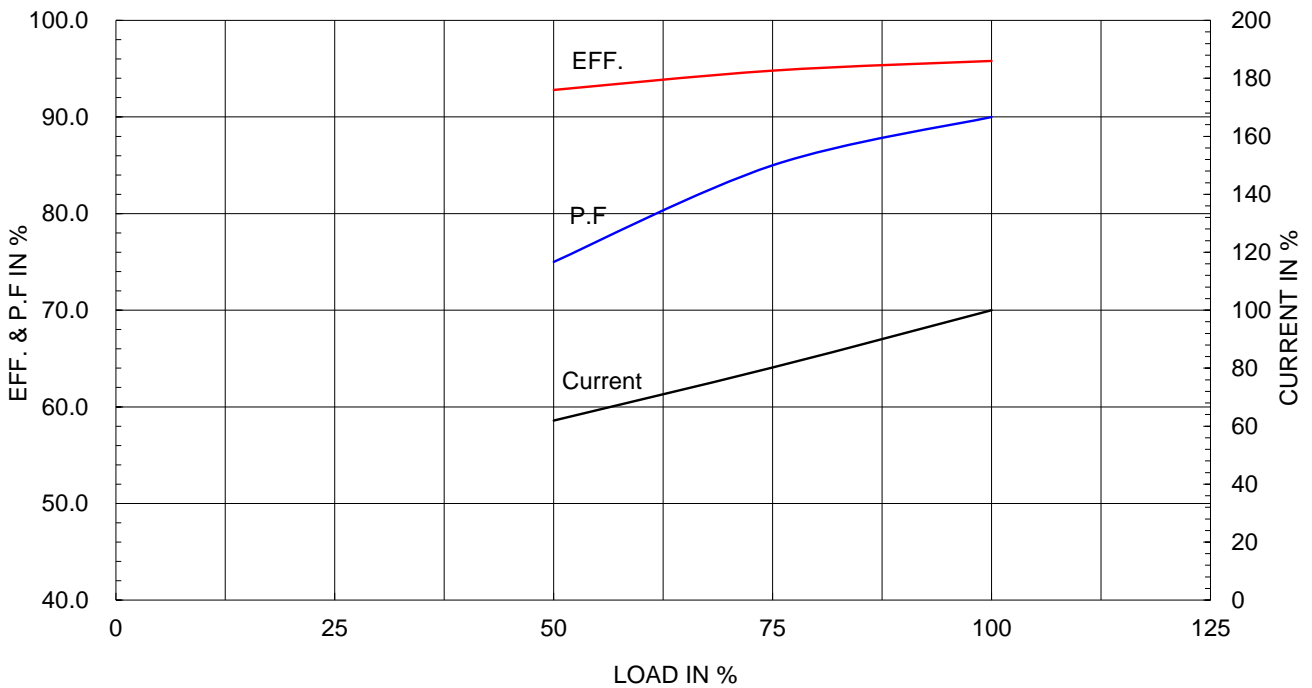

본 도면은 HD현대일렉트릭(주) 재산이며 허가없이 복사할 수 없음 (취급주의)

THIS DRAWING IS PROPRIETARY TO HYUNDAI ELECTRIC. NO PART OF THIS DRAWING MAYBE REPRODUCED WITHOUT THE PERMISSION OF HYUNDAI ELECTRIC.

▽	50S	REV	DATE	CONTENTS	REVD BY	CHKD BY	CHKD BY	APPD BY
▽▽	12.5S							
▽▽▽	3.2S							
▽▽▽▽	0.4S							

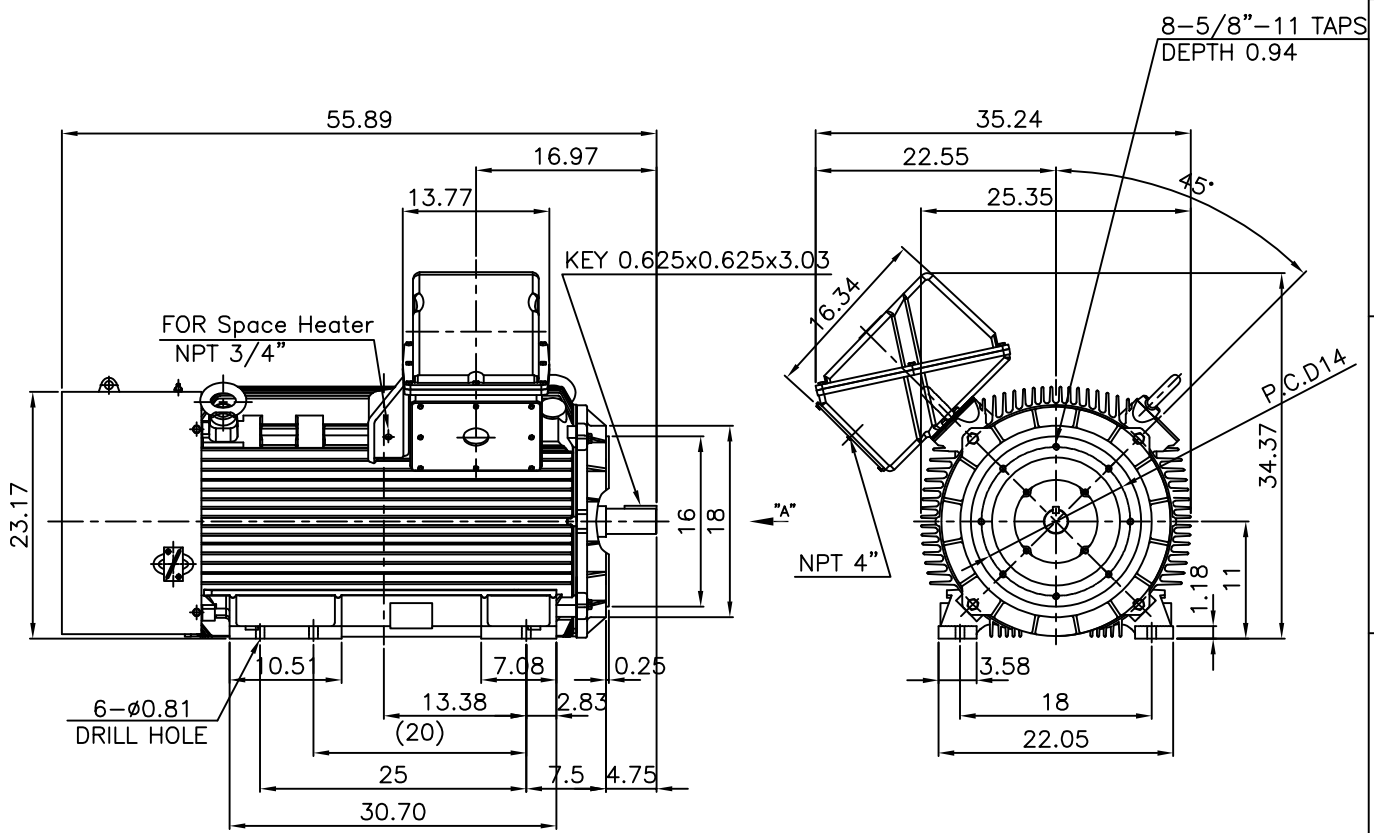

NOTE

1.TOLERANCE :

CENTER HEIGHT	11	+0.000	-0.060
RABBET DIAMETER	φ16	0	-0.005
SHAFT DIAMETER	φ2.375	+0.000	-0.001
KEYWAY WIDTH	0.625	+0.002	-0.000

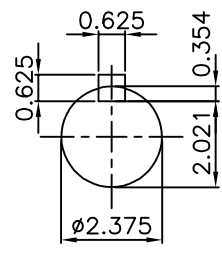

VIEW "A"

APPD BY	S.Y.KIM	UNIT	INCH	SUBJECT	Fr.L449TSC	DWG SIZE	A4 (1:18)
CHKD BY	O.J.KIM	SCALE	1/18	TITLE	OUTLINE		
CHKD BY	R.G.KIM	PROJEC'N	3각법(3rd Angle)	REF. NO		Sheet No.	of
DSND BY	H.K.LEE	DATE	2021-04-27	DWG NO	LM-T044XC4CE001	Revision No.	0

**Cls. I&II, Div. 2
IEEE 841**

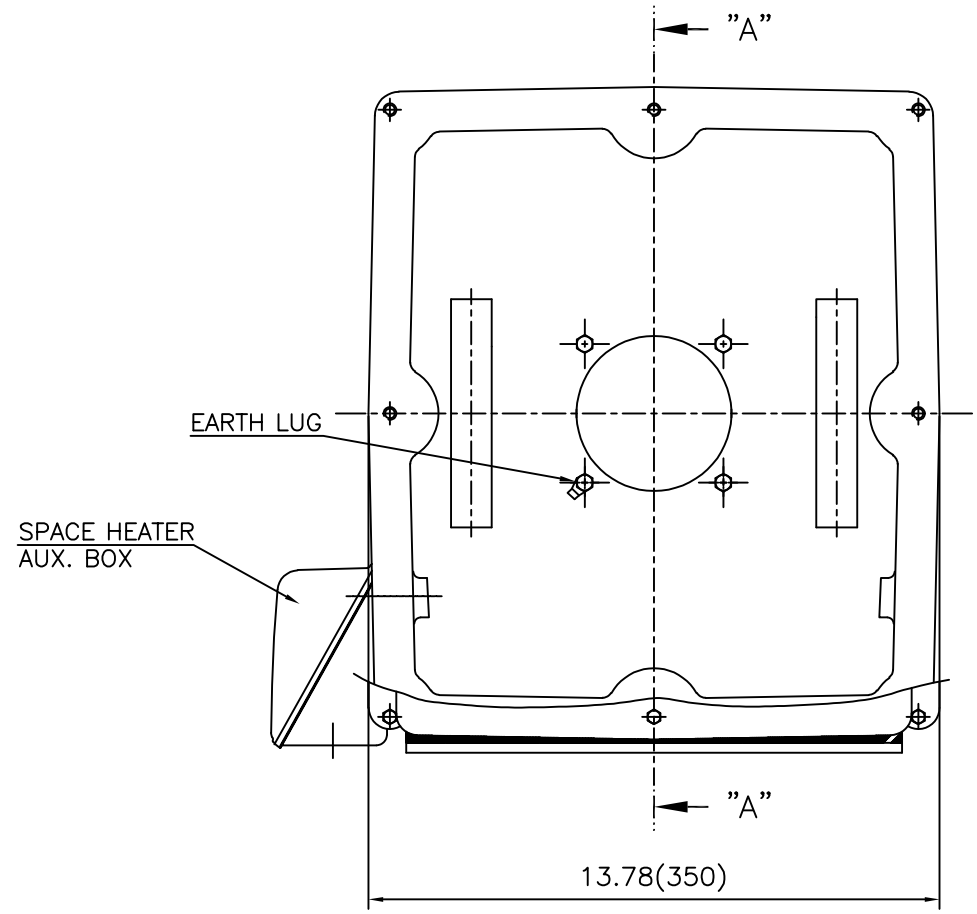

SEC. "A" - "A"

REV	DATE	CONTENTS	REVD BY	CHKD BY	CHKD BY	APPD BY
1						
2						
3						
4						

APPD BY	S.Y.KIM	UNIT	inch(mm)	SUBJECT	FR. L440 (CAST IRON)	DWG SIZE
CHKD BY		SCALE	1/3.5	TITLE	MAIN TERMINAL BOX ASS'Y	A3 (1:3.5)
CHKD BY	R.G.KIM	PROJEC'N	3rd Angle	REF. NO		Sheet No. of
DSND BY	최승희	DATE	2023-10-19	DWG NO		3M-248452



Cls. I&II, Div. 2
IEEE 841

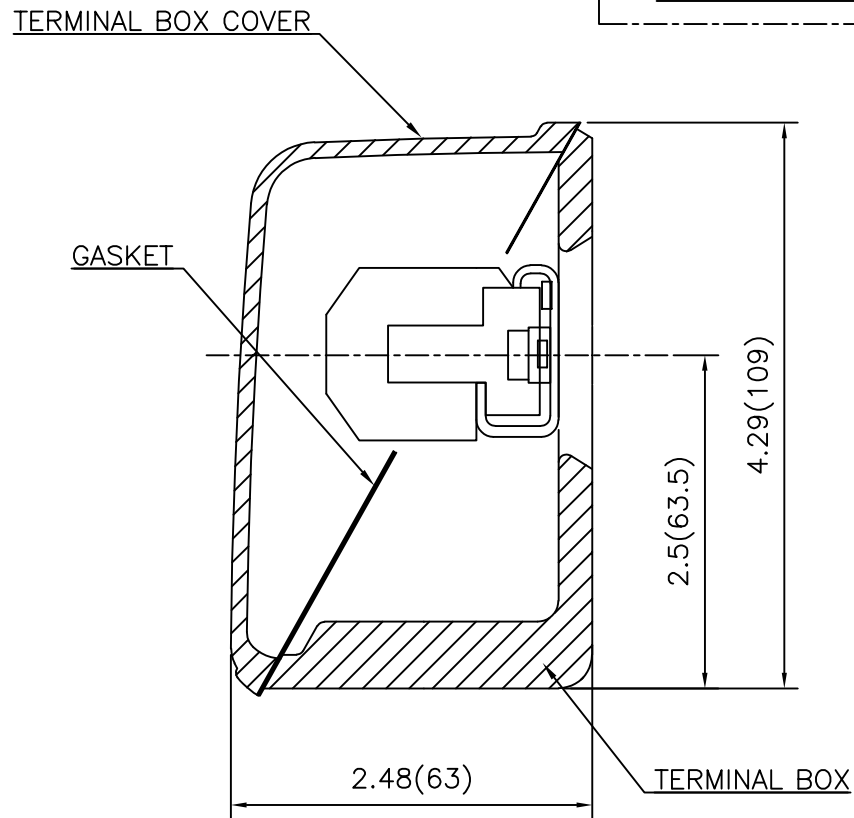

SEC. "A" - "A"

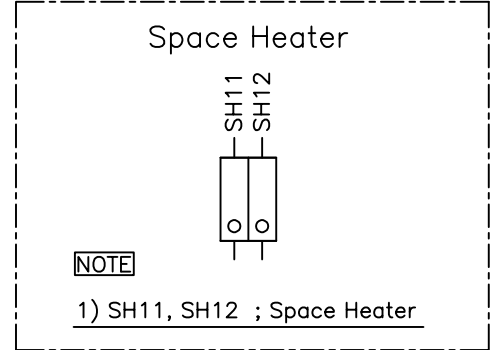

REV	DATE	CONTENTS	REVD BY	CHKD BY	CHKD BY	APPD BY

APPD BY	S.Y.KIM	UNIT	inch(mm)	SUBJECT	FR.180 (CAST IRON)	DWG SIZE	A3 (1:1.1)
CHKD BY		SCALE	1/1	TITLE	SUB. TERMINAL BOX ASS'Y		
CHKD BY	R.G.KIM	PROJEC'N	3rd Angle	REF. NO		Sheet No.	of
DSND BY	배승희	DATE	2024-01-18	DWG NO	3M-165277	Revision No.	0

