

Customer :  
 Project Name :  
 Project No. :  
 Revision No. :

# SPECIFICATION for INDUCTION MOTOR



0		For Bidding			
No.	DATE	DESCRIPTION	PREPARED BY	CHECKED BY	APPROVED BY

# AC INDUCTION MOTOR DATA SHEET

Catalog No.	HSDE400-36-L449TSC-IBSHSP	Item No.		Rev. No.	[     ]
Project Name		Project No.		Quantity	sets

GENERAL SPECIFICATION			PERFORMANCE DATA			
Frame Size	L449TSC		Rated Output	300 kW     400 HP		
Type	PJP		Number of Poles	2		
Enclosure(Protection)	Totally Enclosed	/ IP55	Rotor Type	Squirrel Cage		
Method of Cooling	IC411(FC)		Starting Method*	D.O.L		
Rated Frequency	60 Hz		Rated Voltage	575 V	460 V	230 V
Number of Phases	3		Current	Full Load	349.4 A	436.7 A
Insulation Class	F			Locked-rotor**	680 %	680 %
Temp. Rise at full load (by resistance method)			Efficiency			
at 1.0 S.F	80 deg. C		50% Load		92.8 %	
Motor Location	<input type="checkbox"/> Indoor <input type="checkbox"/> Outdoor		75% Load		94.8 %	
Altitude	Less than 1,000 meter		100% Load		95.8 %	
Relative Humidity	Less than 80 %		Power Factor(p.u)			
Ambient Temp.	40 deg. C (Max.)		50% Load		0.750	
Duty Type	Continuous ( S1 )		75% Load		0.850	
Service Factor	1.15		100% Load		0.900	
Mounting	B35		Speed at Full Load	3570 r.p.m		
Bearing	Type	Anti-Friction	Torque			
	DE/N-DE	6315C3 / 6315C3-INS.	Full Load	592.0 lb.ft		
	Lubricant	Grease(Polyrex-EM)	Locked-rotor**	145 %		
External Thrust	Not applicable		Breakdown**	240 %		
Coupling Method	<input checked="" type="checkbox"/> Direct <input type="checkbox"/> V-belt		Moment of Inertia (J)			
Shaft Extension	Single		Load(Max.)	315.000 lb.ft2		
Terminal Box	Main	Cast Iron	Motor	60.755 lb.ft2		
	Aux.	Yes	Sound Pressure Level (No-load & mean value at 1m from motor)			
	Location	Refer to Outline Drawing		87 dB(A)		
Application			Vibration	3.8 mm/sec (peak)		
Area classification	Hazardous		Permissible number of consecutive starts	Cold	2 times	
Type of Ex-Protection	Class I&II, Division 2			Hot	1 time	
Applicable Standard	NEMA MG1, CSA C390		Paint	Munsell No.	4.0PB5.4/5.5(VL-451)	

### ACCESSORIES

\*. Space Heater : 1EA/Motor

### SPARE PARTS

1. Spare Axial Fan (C.W Direction)

### SUBMITTAL DRAWING

Outline Dimension Drawing		Motor Weight(Approx.)	
B35	LM-T044XC4CE001	3920 lb.	

### REMARK

1. Premium efficiency according to NEMA MG1
2. Inverter Duty @ 1.0 Service Factor & F Temperature rise
  - . 10:1 VT (20:1 VT at 50% load)
  - . 10:1 CT
  - . CHp up to 1.5 times base speed, NEMA MG1 Part31
3. NDE side : Insulated bearing
4. CSA Certification
  - . Class I, Division 2, Group A, B, C & D; Temp code : T3
  - . Class II, Division 2 Group F & G; Temp code : T3
5. Uni-directional CCW viewed from drive end.

Date	DSND	CHKD	CHKD	APPD
2024-09-10	S.H. Lee	I.K. Kim	R.G. Kim	S.W. Kim

[Note] Others not mentioned in this data sheet shall be in accordance with maker standard.  
 Above technical data are only design values and shall be guaranteed with tolerance of applicable standard.  
 Inspection and performance test shall be done according to maker standard, if not mentioned.  
 \* In case of Inverter-Fed Motor, performance data is based on sine wave tests. It may be different from test data of Inverter combined motor.  
 \*\* Data is based on rated voltage & frequency and is expressed as a percentage of full-load value.

1	2	3	4
REV	DATE	CONTENTS	REVD BY CHKD BY CHKD BY APPD BY

4.72

**CROWN TRITON**  
Premium Efficiency AC 3 Phase Motor





400HP	2P	460V	Cat. No.	HSDE400-36-L449TSC-IBSHSP			
Model	LATER		INS. Class	F	Amps	436.7	
Type	PJP	Duty	Code	G	Amb.	40°C	
Frame	L449TSC	Encl.	S.F.	1.15	RPM	3570	
Bearing	Drive	6315C3	S.F.1.00 (10:1 C.T., 20:1 V.T., NEMA-MG1 Part31)		3/4 Eff.	94.8%	
	Opp.	6315C3-INS.			NEMA Design	B	
Usable at	50Hz 335HP 380V 440.54A 2970rpm S.F.: 1.0 Eff.: 95.8% Code: G						
	50Hz 335HP 400/415V 423.22/407.88A 2972/2975rpm S.F.: 1.0 Eff.: 95.8/95.81% Code: H/H						
CSA Certified for	CLASS I, Div. 2, Gr. A, B, C & D		CLASS II, Div. 2, Gr. F & G		Temp. Code (sine wave)	Frame	L440FR - 500FR
	CLASS I, Zone 2, Gr. IIA, IIB, & IIC					Amb. 40°C	T3 (200°C)
						Amb. 55°C	T3 (200°C)
No.	-		Date	-		Weight	3920 lb
	4M-136053		Made in Korea H1				

2.36

APPD BY	S.Y.KIM	UNIT	INCH	SUBJECT	CSA Class I, Division2 Severe Duty (HSDE ,L449-500)	DWG SIZE
CHKD BY	I.K.KIM	SCALE	NONE			A4 ( 1:1 )
CHKD BY	R.G.KIM	PROJEC'N	3rd Angle	NAMEPLATE DRAWING		
DSND BY	S.H.LEE	DATE	2024.06.07			
				REF. NO	4M-136053	Sheet No. of
				DWG NO	NP-HSDE400-36-L449TSC-IBSHSP	Revision No. 0



# PERFORMANCE CURVE

CURVE NO.  
PC-HSDE400-36-L449TSC-IBSHSP

Type :	PJP
Full Load Torque :	592.0 lb.ft
Load moment of Inertia (J) :	315.000 lb.ft2
Motor moment of Inertia (J) :	60.755 lb.ft2

300kW 400HP	2 P	60 Hz
Speed at Full Load :		3570 RPM
Rated Voltage	575V	460V 230V
Full Load Current	349.4A	436.7A 873.4A

SPEED VS TORQUE & CURRENT CURVE

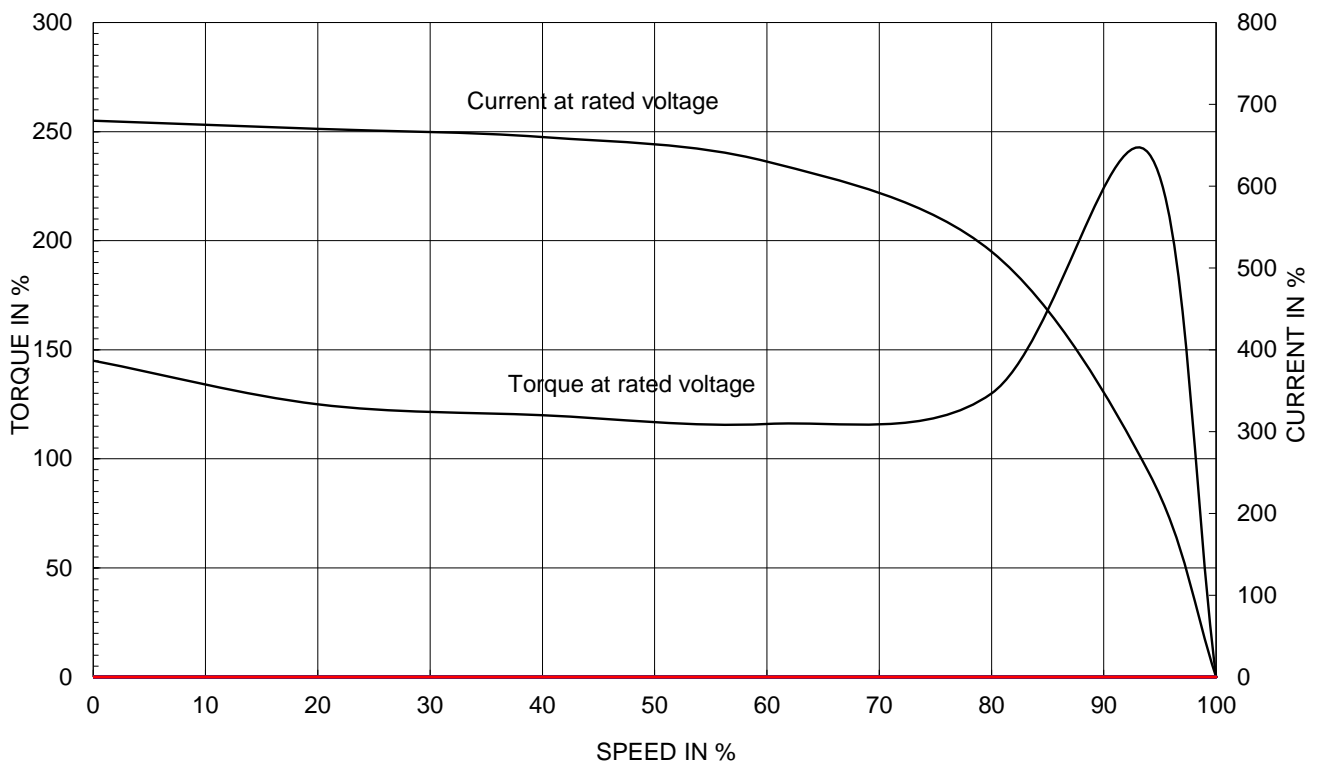

OUTPUT VS EFF., P.F & CURRENT CURVE

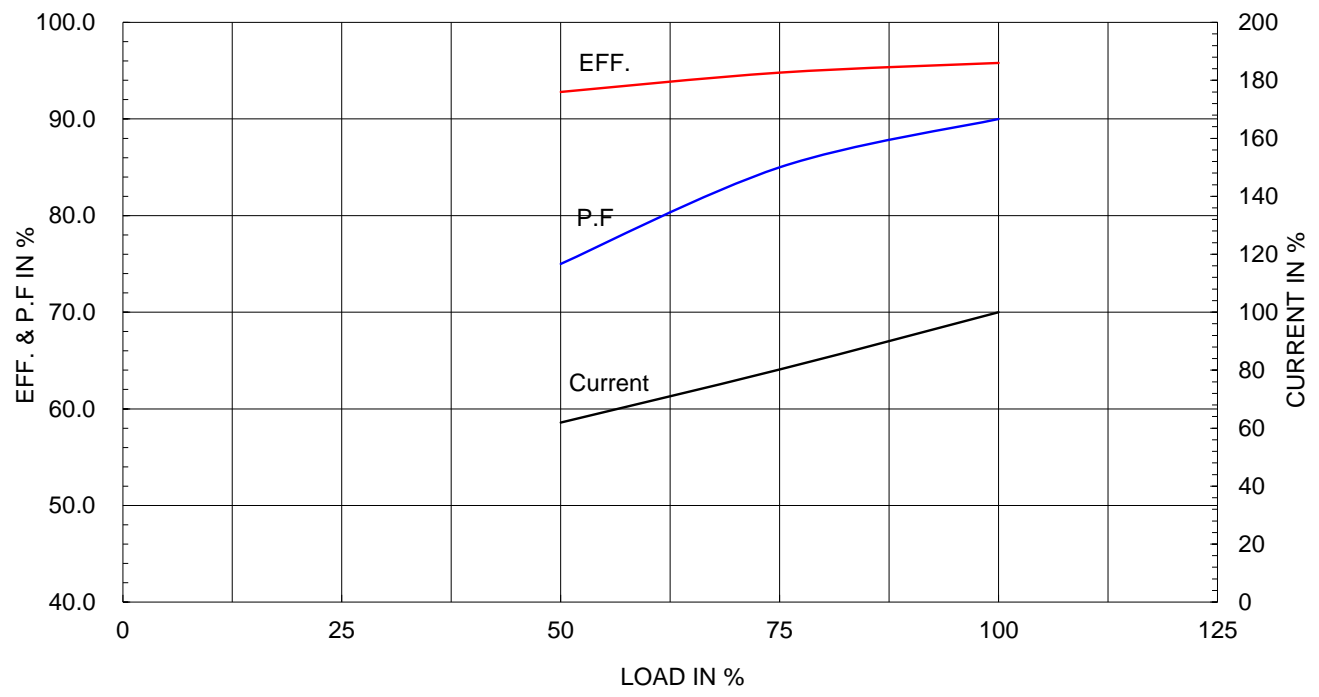

본 도면은 HD현대일렉트릭(주) 재산이며 허가없이 복사할 수 없음 (취급주의)

THIS DRAWING IS PROPRIETARY TO HYUNDAI ELECTRIC. NO PART OF THIS DRAWING MAYBE REPRODUCED WITHOUT THE PERMISSION OF HYUNDAI ELECTRIC.

▽	50S	REV	DATE	CONTENTS	REVD BY	CHKD BY	CHKD BY	APPD BY
▽▽	12.5S							
▽▽▽	3.2S							
▽▽▽▽	0.4S							

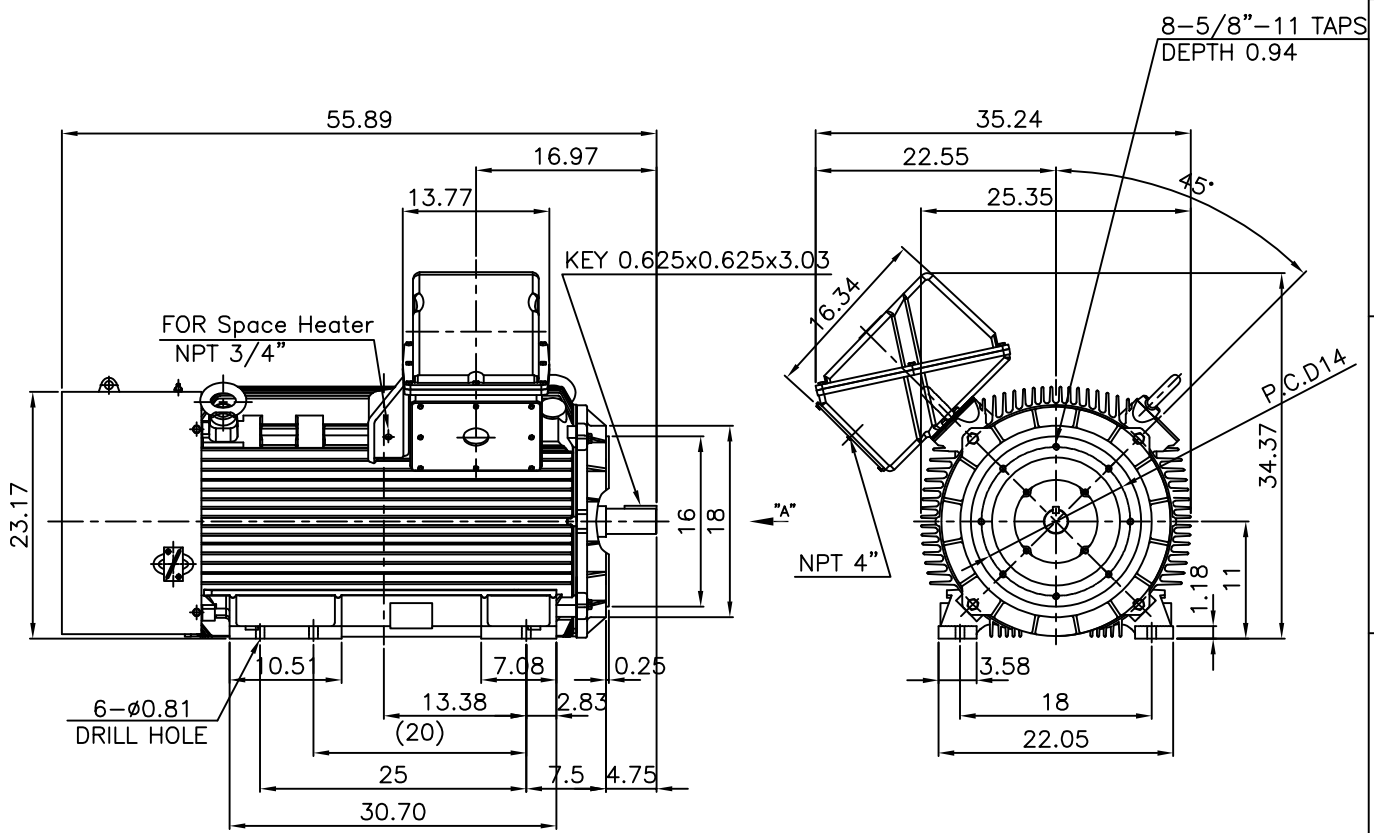

**NOTE**

1.TOLERANCE :

CENTER HEIGHT	11	+0.000	-0.060
RABBET DIAMETER	ø16	0	-0.005
SHAFT DIAMETER	ø2.375	+0.000	-0.001
KEYWAY WIDTH	0.625	+0.002	-0.000

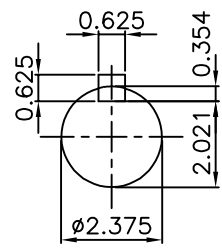

VIEW "A"

APPD BY	S.Y.KIM	UNIT	INCH	SUBJECT	Fr.L449TSC	DWG SIZE	A4 (1:18)
CHKD BY	O.J.KIM	SCALE	1/18	TITLE	OUTLINE		
CHKD BY	R.G.KIM	PROJEC'N	3각법(3rd Angle)				
DSND BY	H.K.LEE	DATE	2021-04-27				



REF. NO		Sheet No.	of
DWG NO	LM-T044XC4CE001	Revision No.	0

**Cls. I&II, Div. 2  
IEEE 841**



SEC. "A" - "A"

REV	DATE	CONTENTS	REVD BY	CHKD BY	CHKD BY	APPD BY
1						
2						
3						
4						

APPD BY	S.Y.KIM	UNIT	inch(mm)	SUBJECT	FR. L440 (CAST IRON)	DWG SIZE
CHKD BY		SCALE	1/3.5	TITLE	MAIN TERMINAL BOX ASS'Y	A3 (1:3.5)
CHKD BY	R.G.KIM	PROJEC'N	3rd Angle			
DSND BY	최승희	DATE	2023-10-19			
				REF. NO		Sheet No. of
				DWG NO	3M-248452	Revision No. 0

THIS DRAWING IS PROPRIETARY TO HYUNDAI ELECTRIC. NO PART OF THIS DRAWING MAY BE REPRODUCED WITHOUT THE PERMISSION OF HYUNDAI ELECTRIC.

본 도면은 HD현대일렉트릭(주) 재산이며 허가없이 복사할 수 없습니다 (취급주의)

**HD HYUNDAI ELECTRIC**

# Cls. I&II, Div. 2

## IEEE 841

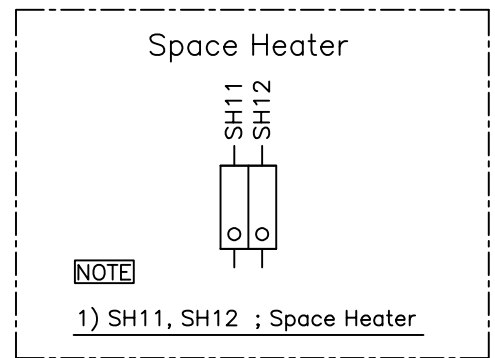
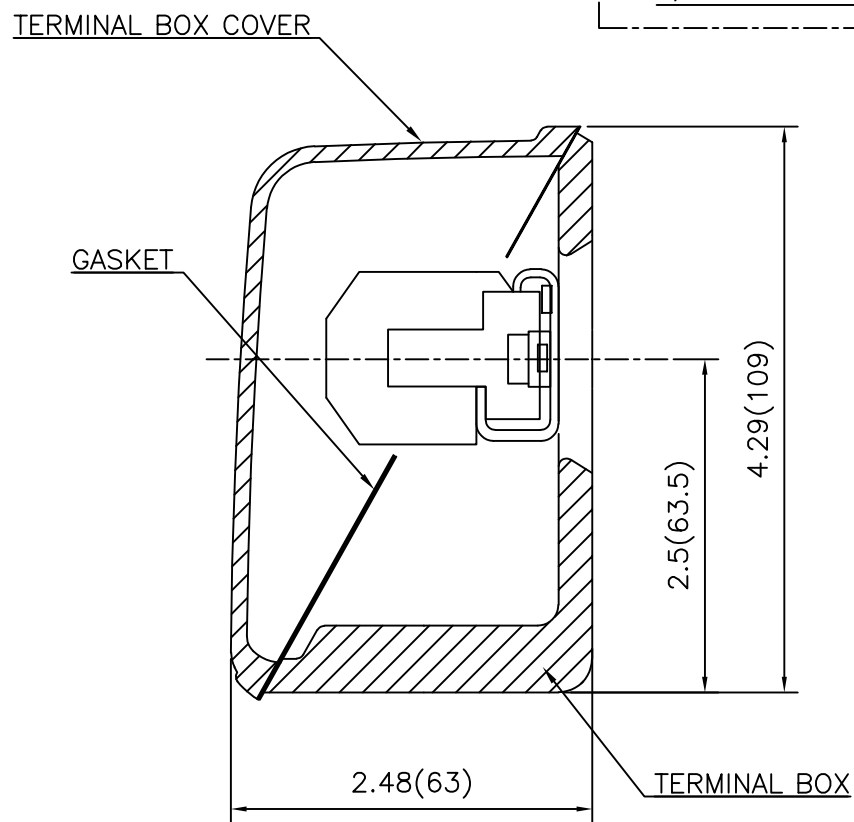
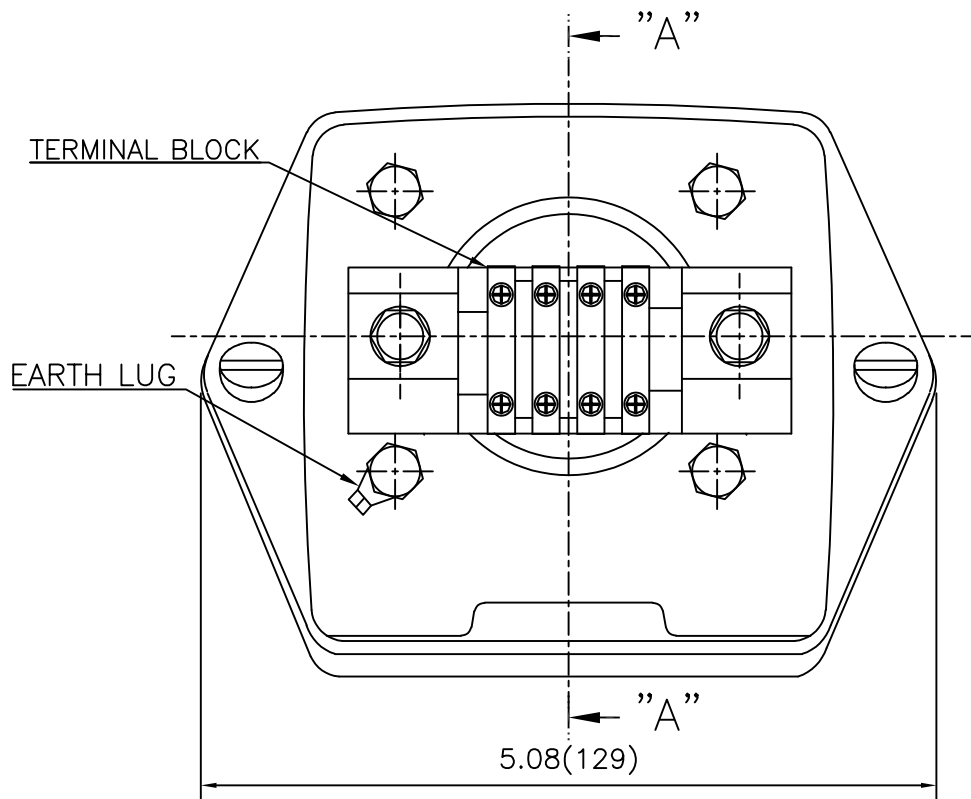

REV	DATE	CONTENTS	REVD BY	CHKD BY	CHKD BY	APPD BY

APPD BY	S.Y.KIM	UNIT	inch(mm)	SUBJECT	FR.180 (CAST IRON)	DWG SIZE
CHKD BY		SCALE	1/1	TITLE	SUB. TERMINAL BOX ASS'Y	A3 (1:1.1)
CHKD BY	R.G.KIM	PROJEC'N	3rd Angle			
DSND BY	배승희	DATE	2024-01-18			
				REF. NO		Sheet No. of
				DWG NO	3M-165277	Revision No. 0