

Customer :
 Project Name :
 Project No. :
 Revision No. :

SPECIFICATION for INDUCTION MOTOR



0		For Bidding			
No.	DATE	DESCRIPTION	PREPARED BY	CHECKED BY	APPROVED BY



AC INDUCTION MOTOR DATA SHEET

IEEE841 TYPE

Catalog No.	IEEE500-36-5010S-IBSHSP	Item No.	Rev. No.	[]
Project Name		Project No.	Quantity	sets

GENERAL SPECIFICATION			PERFORMANCE DATA			
Frame Size	5010S		Rated Output	375 kW 500 HP		
Type	PJP		Number of Poles	2		
Enclosure(Protection)	Totally Enclosed	/ IP55	Rotor Type	Squirrel Cage		
Method of Cooling	IC411(FC)		Starting Method*	D.O.L		
Rated Frequency	60 Hz		Rated Voltage	575 V	460 V	230 V
Number of Phases	3		Current	Full Load	436.7 A	545.9 A 1,091.8 A
Insulation Class	F			Locked-rotor**	725 %	725 % 725 %
Temp. Rise at full load (by resistance method)			Efficiency			
at 1.0 S.F	80 deg. C		50% Load		92.8 %	
Motor Location	<input type="checkbox"/> Indoor <input type="checkbox"/> Outdoor		75% Load		94.8 %	
Altitude	Less than 1,000 meter		100% Load		95.8 %	
Relative Humidity	Less than 80 %		Power Factor(p.u)			
Ambient Temp.	40 deg. C (Max.)		50% Load		0.750	
Duty Type	Continuous (S1)		75% Load		0.850	
Service Factor	1.15		100% Load		0.900	
Mounting	B3		Speed at Full Load	3570 r.p.m		
Bearing	Type	Anti-Friction	Torque			
	DE/N-DE	6315C3 / 6315C3-INS.	Full Load		740.0 lb.ft	
	Lubricant	Grease(Polyrex-EM)	Locked-rotor**		145 %	
External Thrust	Not applicable		Breakdown**		240 %	
Coupling Method	<input checked="" type="checkbox"/> Direct <input type="checkbox"/> V-belt		Moment of Inertia (J)			
Shaft Extension	Single		Load(Max.)		381.000 lb.ft2	
Terminal Box	Main	Cast Iron	Motor		76.418 lb.ft2	
	Aux.	Yes	Sound Pressure Level (No-load & mean value at 1m from motor)			
	Location	Refer to Outline Drawing			87 dB(A)	
Application			Vibration		3.8 mm/sec (peak)	
Area classification	Hazardous		Permissible number of consecutive starts		Cold 2 times Hot 1 time	
Type of Ex-Protection	Class I&II, Division 2		Paint	Munsell No.	7.5BG6/1.5	
Applicable Standard	IEEE841, NEMA MG1, CSA C390					

ACCESSORIES
*. Space Heater : 1EA/Motor

SPARE PARTS
1. Spare Axial Fan (C.W Direction)

SUBMITTAL DRAWING			
Outline Dimension Drawing		Motor Weight(Approx.)	
B3	LM-I0511B3CE001	4800 lb.	

REMARK

1. Premium efficiency according to NEMA MG1
2. Inverter Duty @ 1.0 Service Factor & F Temperature rise
 - . 10:1 VT (20:1 VT at 50% load)
 - . 10:1 CT
 - . CHp up to 1.5 times base speed, NEMA MG1 Part31
3. NDE side : Insulated bearing
4. CSA Certification
 - . Class I, Division 2, Group A, B, C & D; Temp code : T3
 - . Class II, Division 2 Group F & G; Temp code : T3
5. Shaft material : AISI4140
6. Uni-directional CCW viewed from drive end.

Date	DSND	CHKD	CHKD	APPD
2024-09-22	E.J.LEE	I.K. Kim	R.G. Kim	S.W. Kim

[Note] Others not mentioned in this data sheet shall be in accordance with maker standard.
 Above technical data are only design values and shall be guaranteed with tolerance of applicable standard.
 Inspection and performance test shall be done according to maker standard, if not mentioned.
 * In case of Inverter-Fed Motor, performance data is based on sine wave tests. It may be different from test data of Inverter combined motor.
 ** Data is based on rated voltage & frequency and is expressed as a percentage of full-load value.

	REV	DATE	CONTENTS

4.72

2.36

CROWN TRITON
Premium Efficiency AC 3 Phase Motor

500HP 2P 460V	Cat. No. IEEE500-36-5010S-IBSHSP
Model LATER	INS. Class F
Type PJP	Duty CONT
Frame 5010S	Encl. TEFC
Bearing Drive 6315C3	Opp. 6315C3-INS.
Usable at 50Hz 420HP 380V 555.08A 2970rpm S.F.: 1.0 Eff.: 95.8% Code: G	S.F. 1.15 RPM 3570
Usable at 50Hz 420HP 400/415V 533.25/513.93A 2972/2975rpm S.F.: 1.0 Eff.: 95.8/95.81% Code: H/J	NEMA Nom. Eff. 95.8%
CSA Certified for CLASS I, Div. 2, Gr. A, B, C & D CLASS I, Zone 2, Gr. IIA, IIB, & IIC	Temp. Code (sine wave)
No. -	Date -
Weight 4800 lb	

IEEE Std 841-2021 MARINE DUTY IEEE45
 4M-136054 Made in Korea H1

APPD BY	S.Y.KIM	UNIT	INCH	SUBJECT	CSA Class I, Division2 IEEE841 (XL)	DWG SIZE
CHKD BY	I.K.KIM	SCALE	NONE			A4 (1:1)
CHKD BY	R.G.KIM	PROJEC'N	3rd Angle	NAMEPLATE DRAWING		
DSND BY	S.H.LEE	DATE	2024.06.07			
				REF. NO	4M-136054	Sheet No. of
				DWG NO	NP-IEEE500-36-5010S-IBSHSP	Revision No. 0

Type :	PJP
Full Load Torque :	740.0 lb.ft
Load moment of Inertia (J) :	381.000 lb.ft2
Motor moment of Inertia (J) :	76.418 lb.ft2

375kW 500HP	2 P	60 Hz
Speed at Full Load :		3570 RPM
Rated Voltage	575V	460V 230V
Full Load Current	436.7A	545.9A 1091.8A

SPEED VS TORQUE & CURRENT CURVE

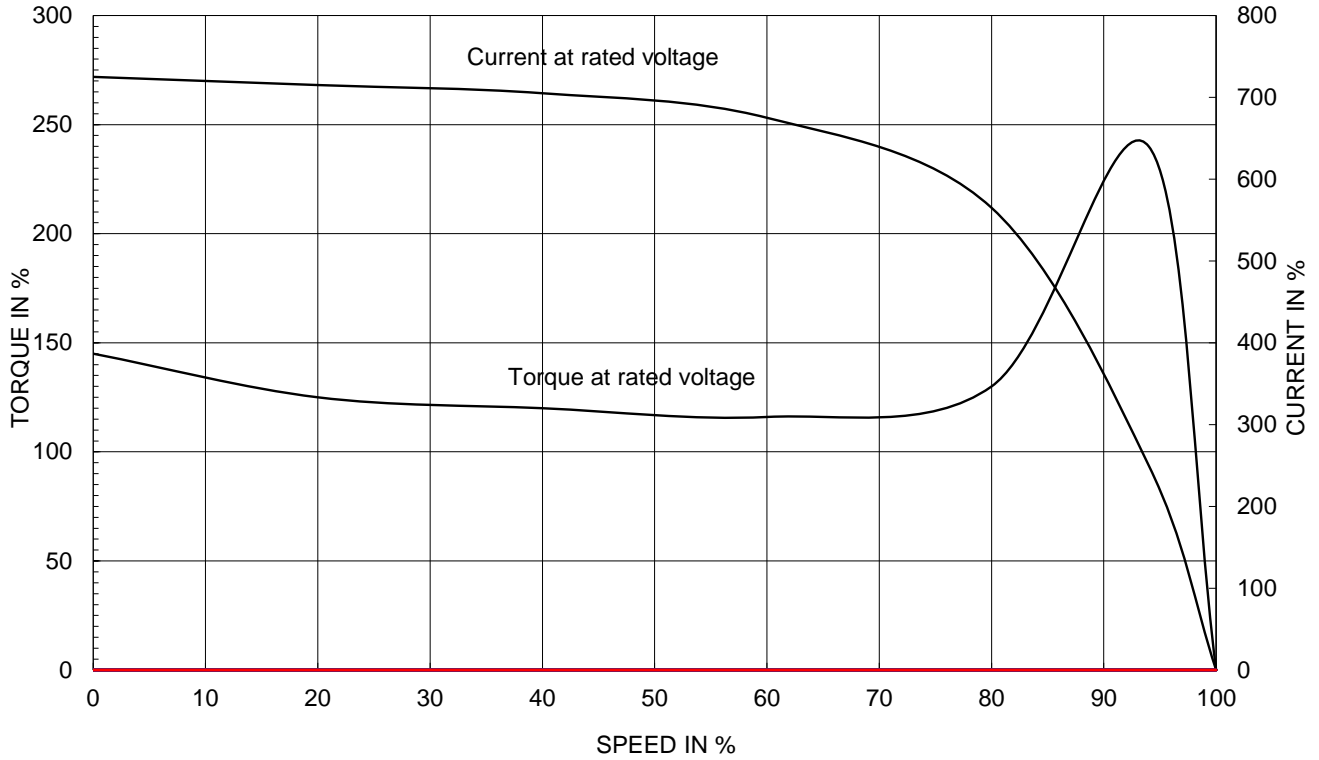

OUTPUT VS EFF., P.F & CURRENT CURVE

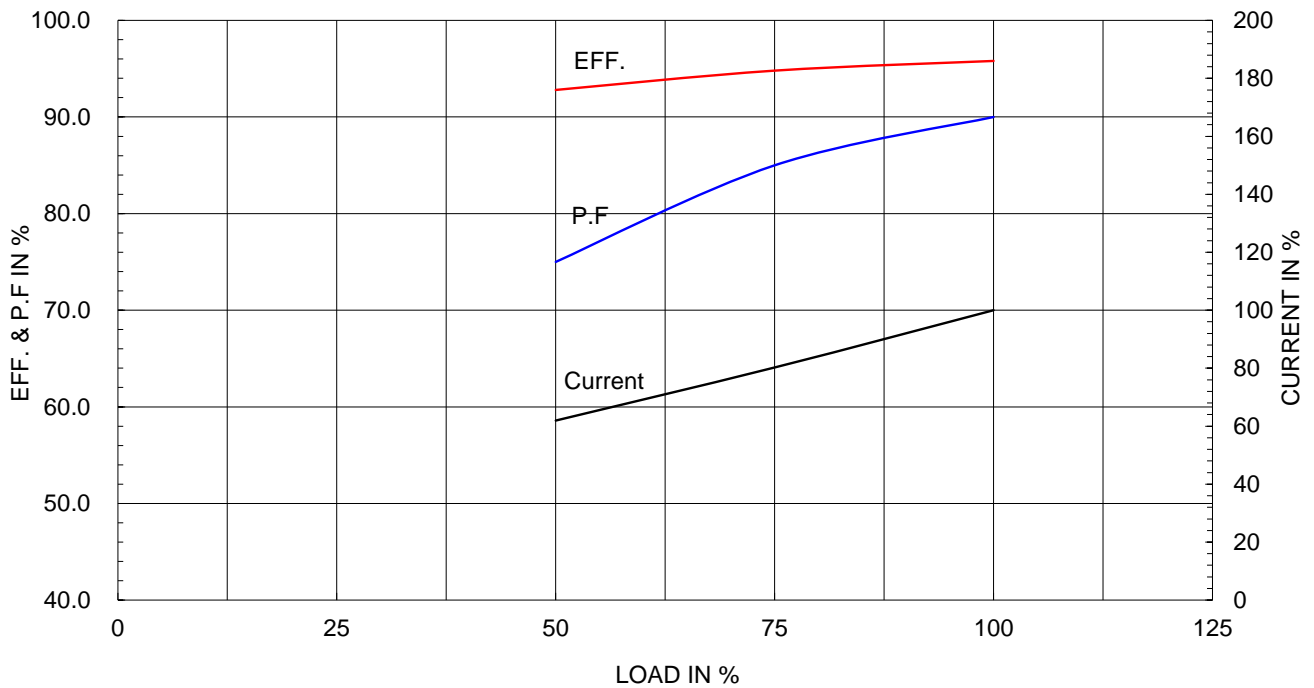

▽	50S	REV	DATE	CONTENTS	REVD BY	CHKD BY	CHKD BY	APPD BY
▽▽	12.5S							
▽▽▽	3.2S							
▽▽▽▽	0.4S							

IEEE841

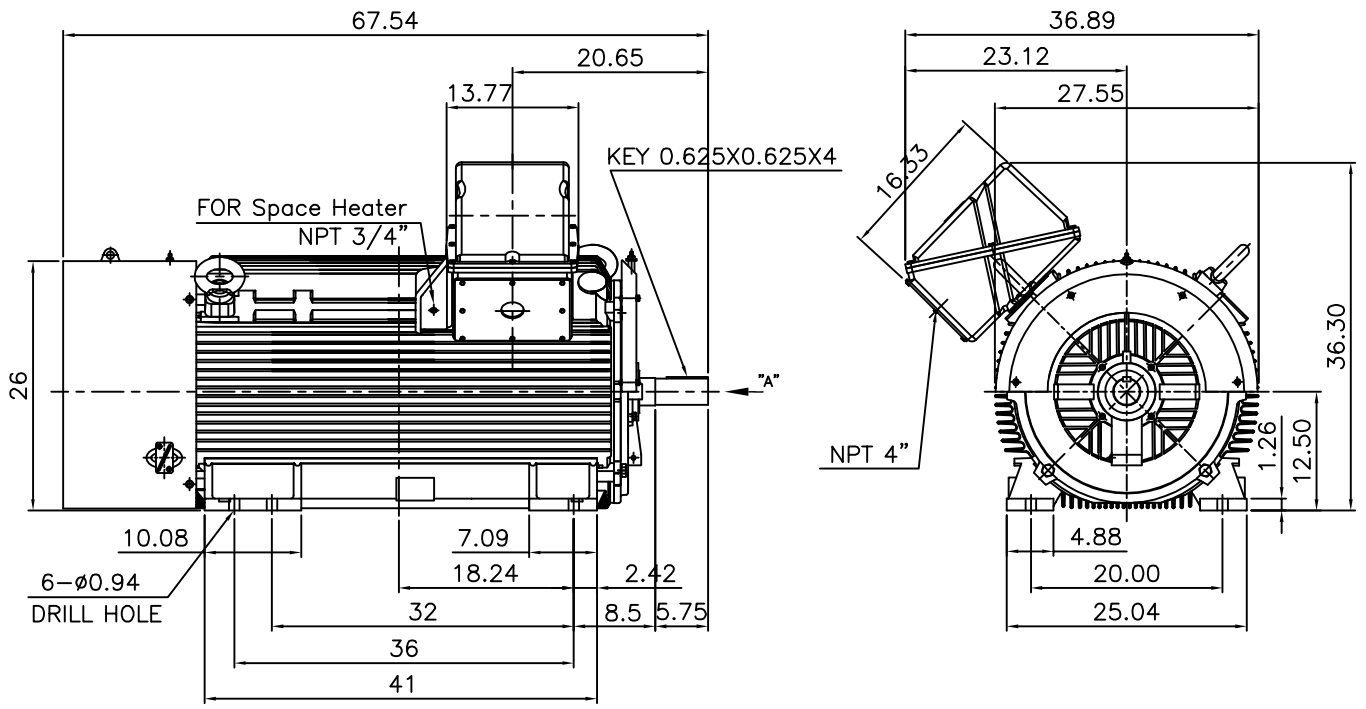

NOTE

1.TOLERANCE :

CENTER HEIGHT	12.5	+0.000	-0.060
SHAFT DIAMETER	ø2.625	+0.000	-0.001
KEYWAY WIDTH	0.625	+0.002	-0.000

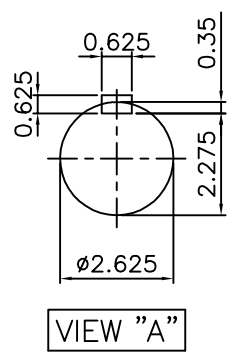

APPD BY	S.Y.KIM	UNIT	INCH	SUBJECT	Fr.5010/5011S	DWG SIZE	A4 (1:20)
CHKD BY	O.J.KIM	SCALE	1/20	TITLE	OUTLINE	Sheet No. of Revision No. 0	
CHKD BY	R.G.KIM	PROJEC'N	3각법(3rd Angle)				
DSND BY	H.K.LEE	DATE	2021-04-27				
				REF. NO			
				DWG NO	LM-I0511B3CE001		

**Cls. I&II, Div. 2
IEEE 841**



SEC. "A" - "A"

REV	DATE	CONTENTS	REVD BY	CHKD BY	CHKD BY	APPD BY

APPD BY	S.Y.KIM	UNIT	inch(mm)	SUBJECT	FR. L440 (CAST IRON)	DWG SIZE
CHKD BY		SCALE	1/3.5	TITLE	MAIN TERMINAL BOX ASS'Y	A3 (1:3.5)
CHKD BY	R.G.KIM	PROJEC'N	3rd Angle			
DSND BY	최승희	DATE	2023-10-19			
				REF. NO		Sheet No. of
				DWG NO	3M-248452	Revision No. 0

**Cls. I&II, Div. 2
IEEE 841**



REV	DATE	CONTENTS	REVD BY	CHKD BY	CHKD BY	APPD BY

APPD BY	S.Y.KIM	UNIT	inch(mm)	SUBJECT	FR.180 (CAST IRON)	DWG SIZE	A3 (1:1.1)
CHKD BY		SCALE	1/1	TITLE	SUB. TERMINAL BOX ASS'Y		
CHKD BY	R.G.KIM	PROJEC'N	3rd Angle	REF. NO		Sheet No.	of
DSND BY	배승희	DATE	2024-01-18	DWG NO	3M-165278	Revision No.	0

