

Customer :  
Project Name :  
Project No. :  
Revision No. :

# SPECIFICATION for INDUCTION MOTOR



0		For Bidding			
No.	DATE	DESCRIPTION	PREPARED BY	CHECKED BY	APPROVED BY



# AC INDUCTION MOTOR DATA SHEET

## Explosion Proof type

Catalog No.	IXHHI50-12-365T	Item No.	Rev. No.	[      ]
Project Name		Project No.	Quantity	sets

GENERAL SPECIFICATION		PERFORMANCE DATA			
Frame Size	365T	Rated Output	37 kW      50 HP		
Type	XJP	Number of Poles	6		
Enclosure(Protection)	Totally Enclosed / IP55	Rotor Type	Squirrel Cage		
Method of Cooling	IC411(FC)	Starting Method*	D.O.L		
Rated Frequency	60 Hz	Rated Voltage	575 V	460 V	230 V
Number of Phases	3	Current	Full Load	48.1 A	60.2 A      120.4 A
Insulation Class	F		Locked-rotor**	680 %	680 %      680 %
Temp. Rise at full load (by resistance method)		Efficiency			
at 1.0 S.F	80 deg. C	50% Load		91.1 %	
Motor Location	<input type="checkbox"/> Indoor <input type="checkbox"/> Outdoor	75% Load		93.1 %	
Altitude	Less than 1,000 meter	100% Load		94.1 %	
Relative Humidity	Less than 80 %	Power Factor(p.u)			
Ambient Temp.	40 deg. C (Max.)	50% Load		0.670	
Duty Type	Continuous ( S1 )	75% Load		0.770	
Service Factor	1.15	100% Load		0.820	
Mounting	B3	Speed at Full Load	1185 r.p.m		
Bearing	Type	Anti-Friction	Torque		
	DE/N-DE	6314C3 / 6213C3	Full Load	220.0 lb.ft	
	Lubricant	Grease(Polyrex-EM)	Locked-rotor**	150 %	
External Thrust	Not applicable	Breakdown**	220 %		
Coupling Method	<input checked="" type="checkbox"/> Direct <input type="checkbox"/> V-belt	Moment of Inertia (J)			
Shaft Extension	Single	Load(Max.)	1,500.593 lb.ft2		
Terminal Box	Main	Cast Iron	Motor	32.000 lb.ft2	
	Aux.	No	Sound Pressure Level (No-load & mean value at 1m from motor)		
Location	Refer to Outline Drawing			73 dB(A)	
Application		Vibration		0.0 mm/sec (peak)	
Area classification	Hazardous	Permissible number of consecutive starts		Cold	0 times
Type of Ex-Protection	Class I, Division 1			Hot	0 times
Applicable Standard	NEMA MG1, CSA C390, UL674	Paint	Munsell No.	4.0PB5.4/5.5(VL-451)	

ACCESSORIES
*. W.T.D.(Thermostat, 145°C) : 1EA/Ph.

SUBMITTAL DRAWING		
Outline Dimension Drawing	Motor Weight(Approx.)	
B3	LM-U0365B3TL001	1173 lb.

SPARE PARTS

REMARK				
1. Premium efficiency according to NEMA MG1				
2. Inverter Duty @ 1.0 Service Factor & Ambient max 45°C				
-. 4:1 CT (10:1 CT at 1hour Duty)				
-. 10:1 VT (20:1 VT at 50% load)				
-. CHP up to 1.5 times base speed, NEMA MG1 Part31				
3. Temperature Code				
-. T3 at 40°C Ambient / T2D at 55°C Ambient				
-. T4 with Winding Temperature Detector				
Date	DSND	CHKD	CHKD	APPD
2024-07-14	S.H. Lee	I.K. Kim	R.G. Kim	S.W. Kim

[Note] Others not mentioned in this data sheet shall be in accordance with maker standard.  
 Above technical data are only design values and shall be guaranteed with tolerance of applicable standard.  
 Inspection and performance test shall be done according to maker standard, if not mentioned.  
 \* In case of Inverter-Fed Motor, performance data is based on sine wave tests. It may be different from test data of Inverter combined motor.  
 \*\* Data is based on rated voltage & frequency and is expressed as a percentage of full-load value.

1	2	3	4
REV	DATE	CONTENTS	REVD BY

4.72

**CROWN TRITON**  
Premium Efficiency AC 3 Phase Motor

**Explosion Proof**







50HP	6P	230/460V	Cat. No.	IXHHI50-12-365T	Amps	120.4/60.
Model	LATER		INS. Class	F HD-F1	Hertz	60Hz
Type	XJP	Duty	CONT	Code	H	NEMA Norm. Eff.
Frame	365T	Encl.	TEFC	S.F.	1.15	3/4 Eff.
Bearing	Drive	6314C3	S.F.	1.00	on sine wave power	NEMA Design
	Opp.	6213C3	RPM	1185	on PWM or IGBT power	B Torque
Usable at	50Hz 50HP 380V 72.5A 981rpm S.F.: 1.0 Eff.: 92.9% Code: F					
	50Hz 50HP 400/415V 69.6/68.1A 983/984rpm S.F.: 1.0 Eff.: 93.2/93.4% Code: G/H					
UL Certified for	Class I, Div. 1, Group C&D / Class I, Zone 1, Group IIA & IIB				Temp. Code	T3 at 40°C Amb. / T2D at 55°C Amb.
	10:1VT(20:1 at 50% load) 4:1CT(10:1 1hour duty at lowest RPM)					T4 With Thermostat
No.	-		Date	-		Weight
4M-136067 (NEMA 320~444Fr.)		Made in Korea H1				

2.36

APPD BY	S.Y.KIM	UNIT	INCH	SUBJECT	UL Class I, Division1 (IXHHI)	DWG SIZE
CHKD BY	I.K.KIM	SCALE	NONE			A4 ( 1:1 )
CHKD BY	R.G.KIM	PROJEC'N	3rd Angle	TITLE <b>NAMEPLATE DRAWING</b>		
DSND BY	S.H.LEE	DATE	2024.06.07			
				REF. NO	<b>4M-136067</b>	Sheet No. of
				DWG NO	<b>NP-IXHHI50-12-365T</b>	Revision No. <b>0</b>

Type :	XJP	
Full Load Torque :	220.0	lb.ft
Load moment of Inertia (J) :	1500.593	lb.ft <sup>2</sup>
Motor moment of Inertia (J) :	32.000	lb.ft <sup>2</sup>

37kW	50HP	6 P	60 Hz
Speed at Full Load :			1185 RPM
Rated Voltage	575V	460V	230V
Full Load Current	48.1A	60.2A	120.4A

SPEED VS TORQUE & CURRENT CURVE

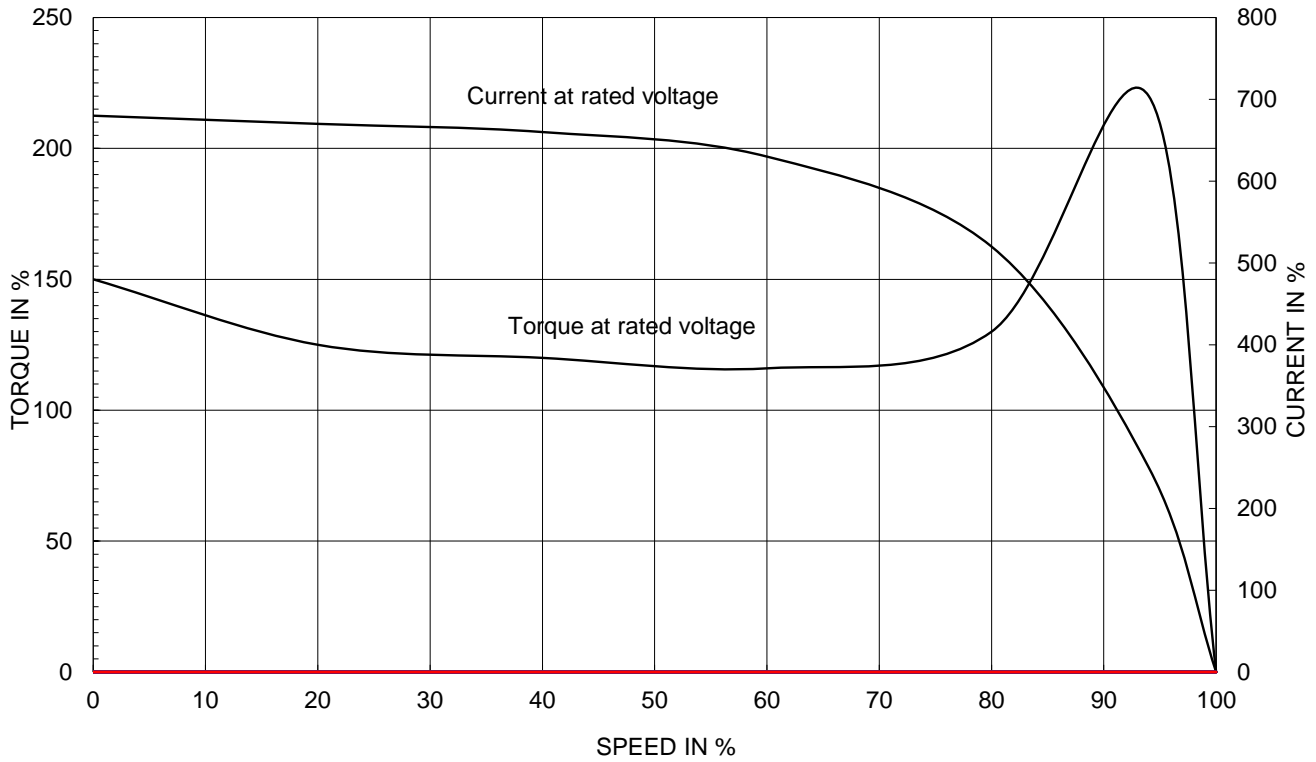

OUTPUT VS EFF., P.F & CURRENT CURVE

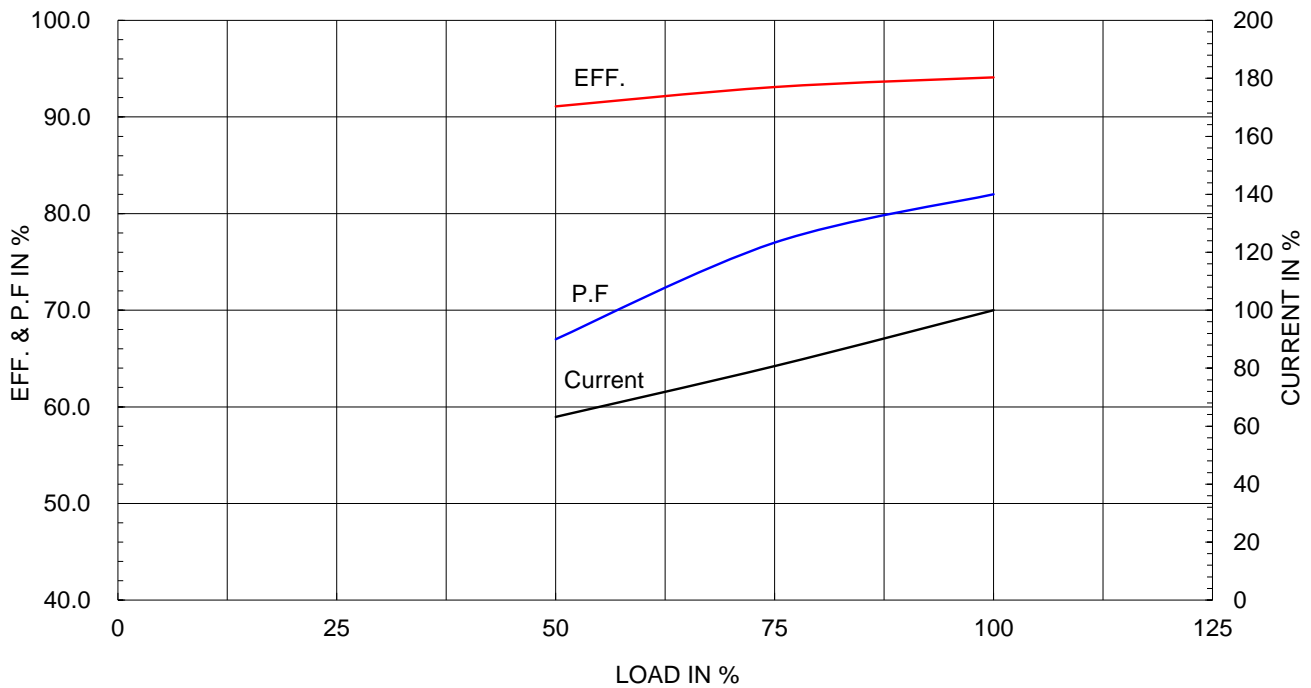

본 도면은 HD현대일렉트릭(주) 재산이며 허가없이 복사할 수 없음 (최급유위)

THIS DRAWING IS PROPRIETARY TO HYUNDAI ELECTRIC. NO PART OF THIS DRAWING MAYBE REPRODUCED WITHOUT THE PERMISSION OF HYUNDAI ELECTRIC.

▽	50S	REV	DATE	CONTENTS	REVD BY	CHKD BY	CHKD BY	APPD BY
▽▽	12.5S							
▽▽▽	3.2S							
▽▽▽▽	0.4S							

**Class I Division 1**

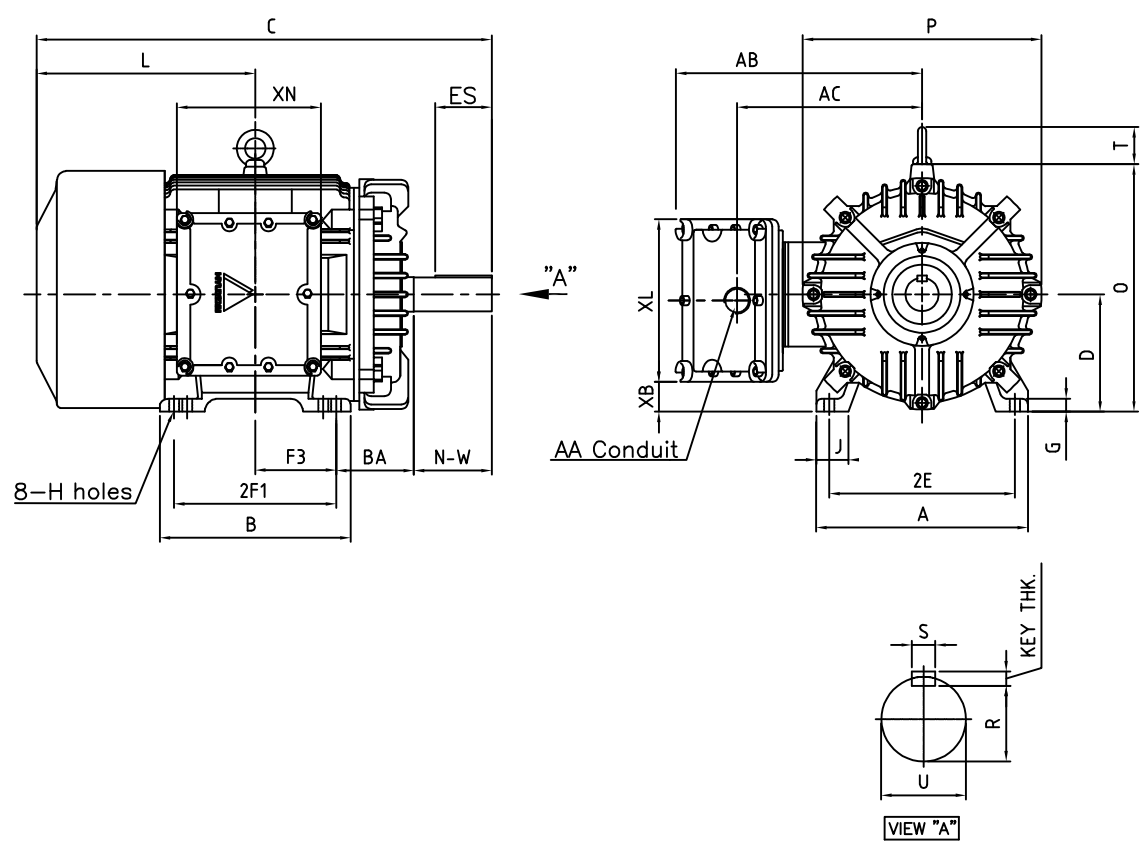

DIMENSIONS

MOUNTING									CONDUIT BOX						APPROX. WGT.(LB)
A	B	2E	2F1	2F2	F3	G	J	H	AA	AB	AC	XB	XL	XN	
15.98	14.41	14.00	12.25	-	6.122	0.98	2.44	0.66	3.00	18.89	14.37	2.24	12.28	10.86	

OVERALL							SHAFT					KEY	BEARING	
BA	C	D	L	O	P	T	U	N-W	KEYWAY			THK.	DRIVE END	OPP. DRIVE END
									R	ES	S			
5.88	34.38	9.00	16.51	18.70	18.03	2.80	2.375	5.88	2.021	4.28	0.625	0.625	6314C3	6213C3

NOTE

1. Dimension "D" tolerance : +0.00inch - 0.03inch (143T-365T) ; +0.000inch - 0.06inch (404T-449T)
2. Dimension "U" tolerance : +0.000inch - 0.005inch (143T-215T), +0.000inch - 0.001inch (254T-449T)
3. Dimension "R" tolerance : +0.000inch - 0.015inch

APPD BY	S.Y.KIM	UNIT	inch	SUBJECT	365T	DWG SIZE	A4 ( 1:15 )
CHKD BY	R.G.KIM	SCALE	1/15	TITLE	OUTLINE		
CHKD BY		PROJEC'N	3rd Angle				
DSND BY	J.H.JEON	DATE	2021-04-19				



REF. NO		Sheet No.	of
DWG NO	LM-U0365B3TL001	Revision No.	0



# Cls. I Div. 1

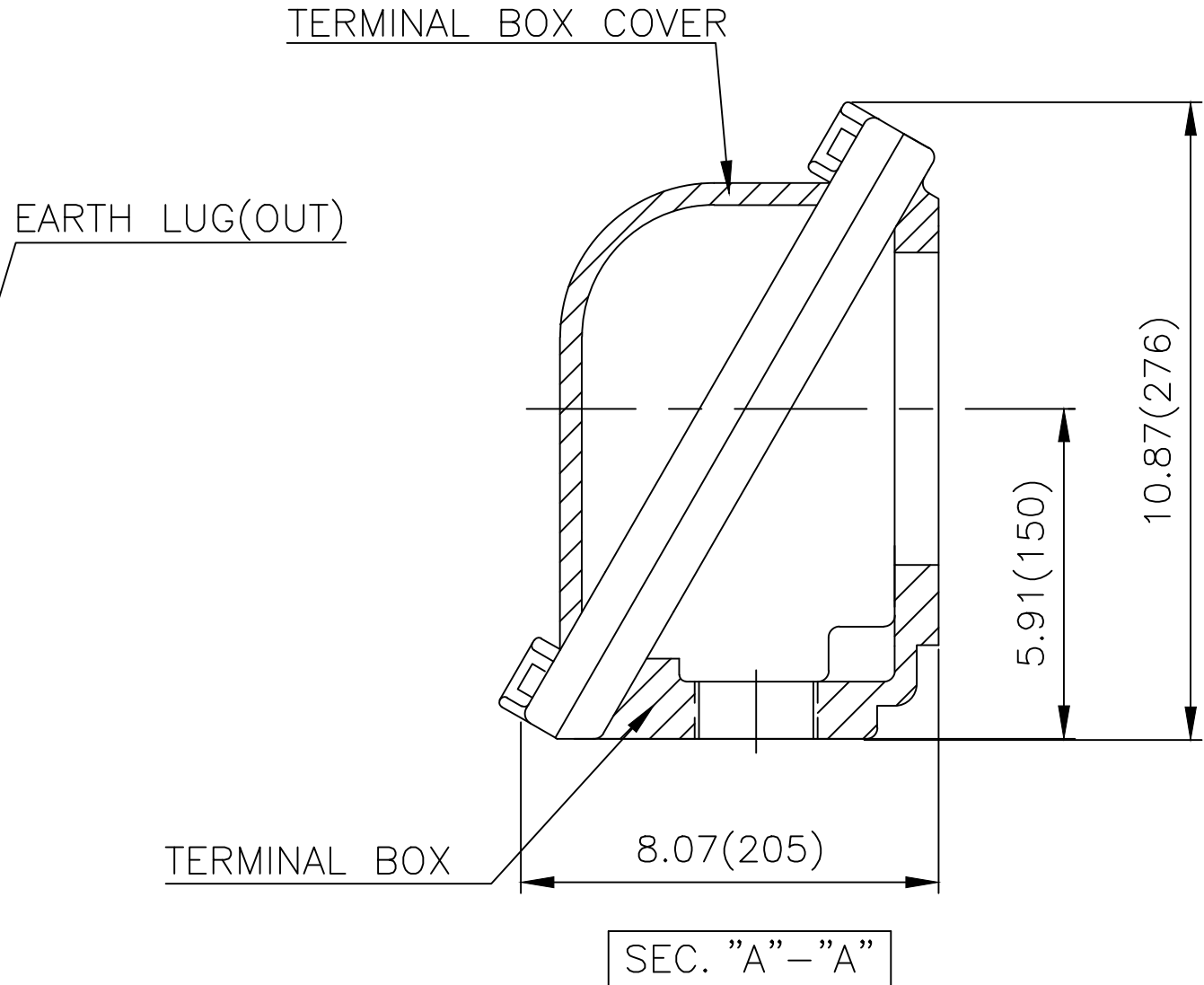
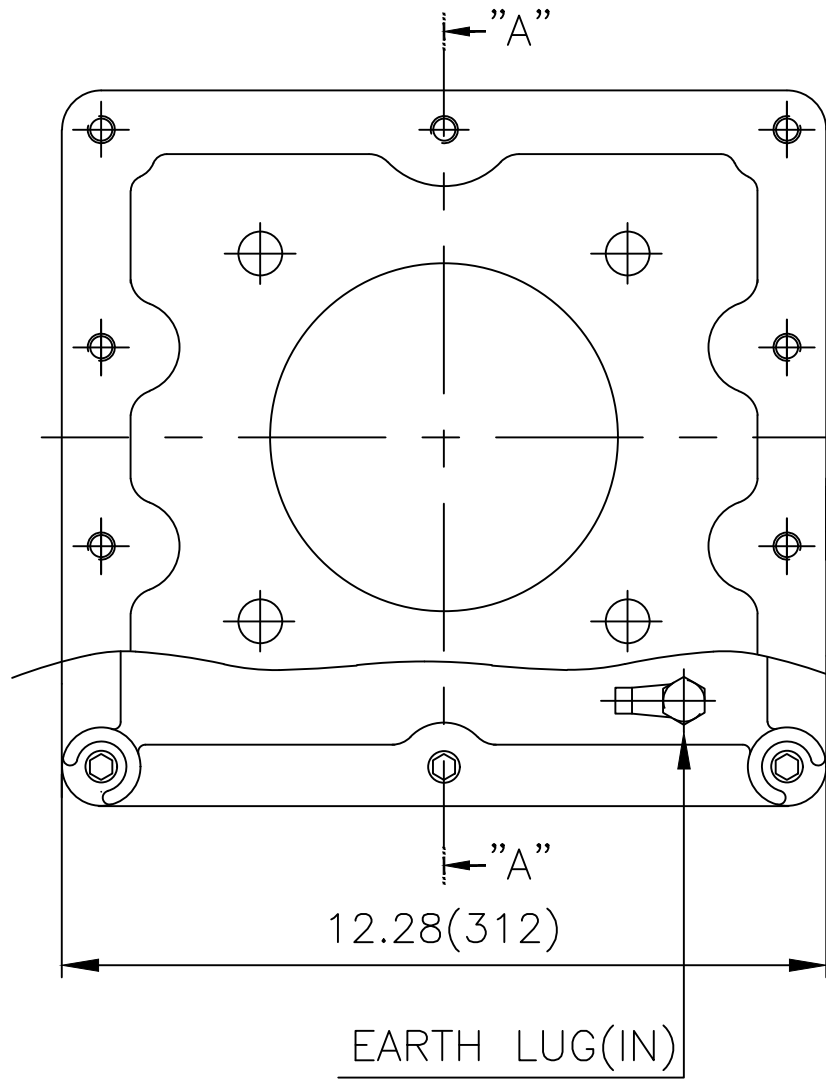

▽	50S
▽▽	12.5S
▽▽▽	3.2S
▽▽▽▽	0.4S

REV	DATE	CONTENTS	REVD BY	CHKD BY	CHKD BY	APPD BY

일반가공공차		일반제관공차	
1-4	±0.1	6-30	±0.5
4-18	±0.2	30-120	±0.8
18-63	±0.3	120-315	±1.2
63-250	±0.5	315-1000	±2.0
250-	±0.8	1000-	±3.0

Q'TY	DESCRIPTION	MATERIAL	DIMENSION	WEIGHT	PART NO.	REMARK	NO.
APPD BY	S.Y.KIM	UNIT	inch(mm)	SUBJECT	NEMA FR. 360(CAST IRON)	DWG SIZE	A3 ( 1:3 )
CHKD BY	R.G.KIM	SCALE	1/3	TITLE	MAIN TERMINAL BOX ASS'Y		
CHKD BY		PROJEC'N	3rd Angle	REF. NO		Sheet No.	of
DSND BY	김은진	DATE	2023-11-08	DWG NO	3M-248635	Revision No.	0

