

Customer :  
Project Name :  
Project No. :  
Revision No. :

# SPECIFICATION for INDUCTION MOTOR



0		For Bidding			
No.	DATE	DESCRIPTION	PREPARED BY	CHECKED BY	APPROVED BY



# AC INDUCTION MOTOR DATA SHEET

## Explosion Proof type

Catalog No.	IXHHI150-18-445T	Item No.		Rev. No.	[ ]
Project Name		Project No.		Quantity	sets

GENERAL SPECIFICATION			PERFORMANCE DATA			
Frame Size	445T		Rated Output	110 kW		150 HP
Type	XJP		Number of Poles	4		
Enclosure(Protection)	Totally Enclosed	/ IP55	Rotor Type	Squirrel Cage		
Method of Cooling	IC411(FC)		Starting Method*	D.O.L		
Rated Frequency	60 Hz		Rated Voltage	575 V	460 V	230 V
Number of Phases	3		Current	Full Load	131.0 A	163.8 A
Insulation Class	F			Locked-rotor**	700 %	700 %
Temp. Rise at full load (by resistance method)			Efficiency			
at 1.0 S.F	80 deg. C		50% Load		92.8 %	
Motor Location	<input type="checkbox"/> Indoor <input type="checkbox"/> Outdoor		75% Load		94.8 %	
Altitude	Less than 1,000 meter		100% Load		95.8 %	
Relative Humidity	Less than 80 %		Power Factor(p.u)			
Ambient Temp.	40 deg. C (Max.)		50% Load		0.730	
Duty Type	Continuous ( S1 )		75% Load		0.830	
Service Factor	1.15		100% Load		0.880	
Mounting	B3		Speed at Full Load	1785 r.p.m		
Bearing	Type	Anti-Friction	Torque			
	DE/N-DE	NU318 / 6314C3	Full Load		434.1 lb.ft	
	Lubricant	Grease(Polyrex-EM)	Locked-rotor**		140 %	
External Thrust	Not applicable		Breakdown**		220 %	
Coupling Method	<input checked="" type="checkbox"/> Direct <input type="checkbox"/> V-belt		Moment of Inertia (J)			
Shaft Extension	Single		Load(Max.)		1,855.724 lb.ft2	
Terminal Box	Main	Cast Iron	Motor		67.430 lb.ft2	
	Aux.	No	Sound Pressure Level (No-load & mean value at 1m from motor)			
	Location	Refer to Outline Drawing			85 dB(A)	
Application			Vibration			
Area classification	Hazardous				0.0 mm/sec (peak)	
Type of Ex-Protection	Class I, Division 1		Permissible number of consecutive starts		Cold 0 times	
Applicable Standard	NEMA MG1, CSA C390, UL674				Hot 0 times	
			Paint	Munsell No.	4.0PB5.4/5.5(VL-451)	

ACCESSORIES
*. W.T.D.(Thermostat, 145°C) : 1EA/Ph.

SPARE PARTS

SUBMITTAL DRAWING		
Outline Dimension Drawing	Motor Weight(Approx.)	
B3	LM-U0445B3TL001	2293 lb.

REMARK
1. Premium efficiency according to NEMA MG1
2. Inverter Duty @ 1.0 Service Factor & Ambient max 45°C
- . 4:1 CT (10:1 CT at 1hour Duty)
- . 10:1 VT (20:1 VT at 50% load)
- . CHP up to 1.5 times base speed, NEMA MG1 Part31
3. Temperature Code
- . T3 at 40°C Ambient / T2D at 55°C Ambient
- . T4 with Winding Temperature Detector @ 1.0 Service Factor

Date	DSND	CHKD	CHKD	APPD
2024-07-14	S.H. Lee	I.K. Kim	R.G. Kim	S.W. Kim

[Note] Others not mentioned in this data sheet shall be in accordance with maker standard.  
 Above technical data are only design values and shall be guaranteed with tolerance of applicable standard.  
 Inspection and performance test shall be done according to maker standard, if not mentioned.  
 \* In case of Inverter-Fed Motor, performance data is based on sine wave tests. It may be different from test data of Inverter combined motor.  
 \*\* Data is based on rated voltage & frequency and is expressed as a percentage of full-load value.

1	2	3	4
REV	DATE	CONTENTS	REVD BY

4.72

**CROWN TRITON** Explosion Proof

Premium Efficiency AC 3 Phase Motor

150HP	4P	460V	Cat. No.	IXHHI150-18-445T	Amps	163.8	
Model	LATER		INS. Class	F HD-F1	Hertz	60Hz	
Type	XJP	Duty	CONT	Code	G	NEMA Nom. Eff.	95.8%
Frame	445T	Encl.	TEFC	S.F.	1.15	on sine wave power	3/4 Eff. 94.8%
Bearing	Drive	NU318	S.F.	1.00	on PWM or IGBT power	NEMA Design	B
	Opp.	6314C3	RPM	1785		Amb.	40°C
Usable at	50Hz 150HP 380V 197.9A 1480rpm S.F.: 1.0 Eff.: 95.2% Code: E						
	50Hz 150HP 400/415V 189.1/184.4A 1482/1484rpm S.F.: 1.0 Eff.: 95.5/95.6% Code: F/G						
UL Certified for	Class I, Div. 1, Group C&D / Class I, Zone 1, Group II A & II B				Temp. Code (sine wave)	T3 at 40°C Amb. / T2D at 55°C Amb.	
	10:1VT(20:1 at 50% load) 4:1CT(10:1 1hour duty at lowest RPM) CHP upto 1.5 time base speed, NEMA MGI part 31. Amb max 45°C for inverter duty.					T4 (S.F.:1.0)  With Thermostat TH01 145°C TH02	
No.	-		Date	-		Weight	2292.807

4M-136016 (NEMA 445~449Fr.) Made in Korea H1

2.36

APPD BY	S.Y.KIM	UNIT	INCH	SUBJECT	UL Class I, Division1 (IXHHI)	DWG SIZE
CHKD BY	I.K.KIM	SCALE	NONE			A4 ( 1:1 )
CHKD BY	R.G.KIM	PROJEC'N	3rd Angle	TITLE <b>NAMEPLATE DRAWING</b>		
DSND BY	S.H.LEE	DATE	2024.06.07			



REF. NO	<b>4M-136016</b>	Sheet No.	of
DWG NO	<b>NP-IXHHI150-18-445T</b>	Revision No.	<b>0</b>

Type :	XJP
Full Load Torque :	434.1 lb.ft
Load moment of Inertia (J) :	1855.724 lb.ft2
Motor moment of Inertia (J) :	67.430 lb.ft2

110kW 150HP	4 P	60 Hz
Speed at Full Load :		1785 RPM
Rated Voltage	575V	460V 230V
Full Load Current	131.0A	163.8A 327.5A

SPEED VS TORQUE & CURRENT CURVE

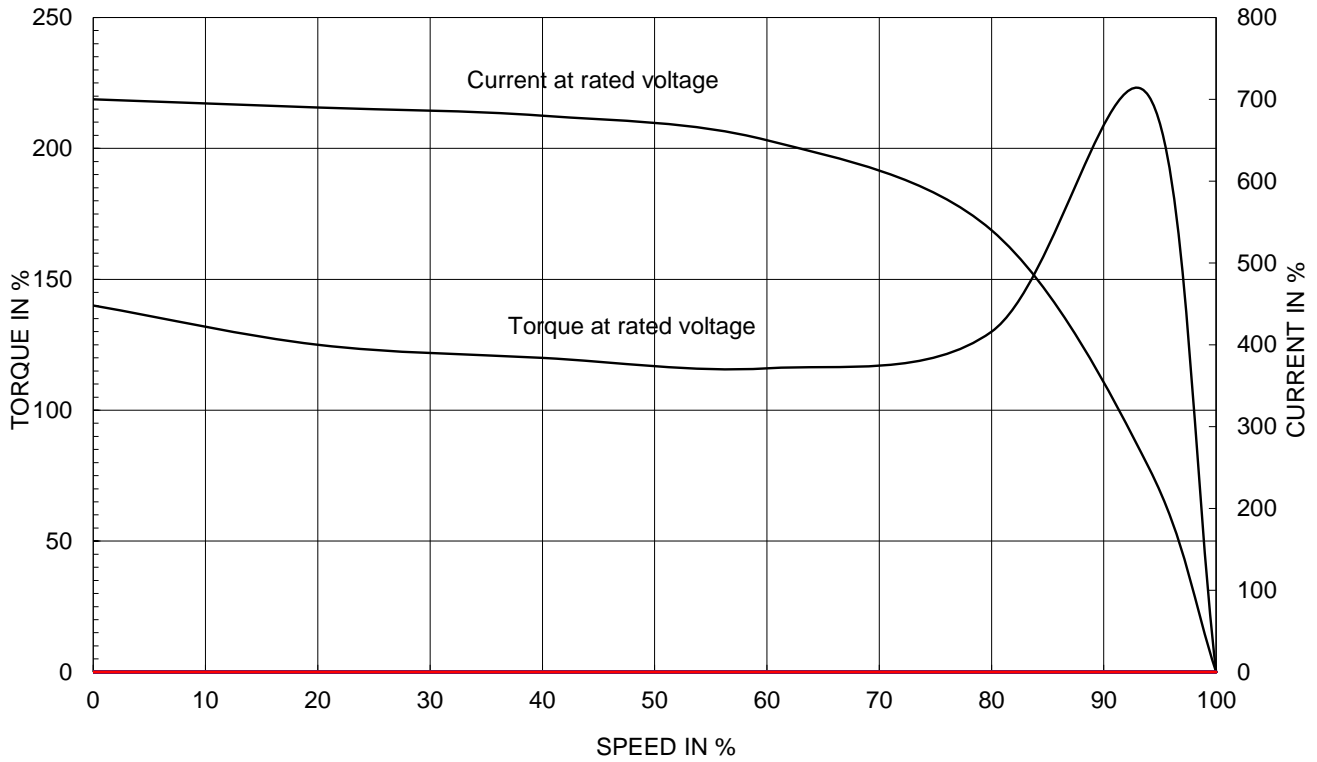

OUTPUT VS EFF., P.F & CURRENT CURVE

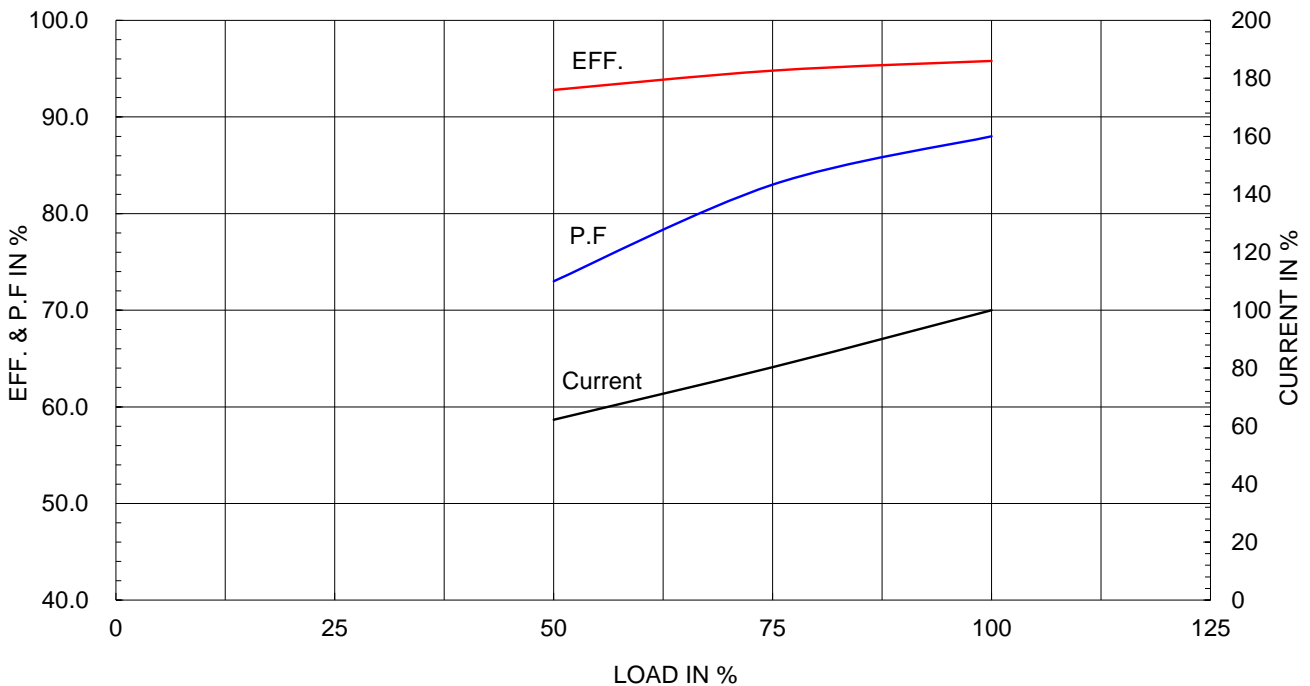

본 도면은 HD현대일렉트릭(주) 재산이며 허가없이 복사할 수 없음 (취급주의)

THIS DRAWING IS PROPRIETARY TO HYUNDAI ELECTRIC. NO PART OF THIS DRAWING MAYBE REPRODUCED WITHOUT THE PERMISSION OF HYUNDAI ELECTRIC.

▽	50S	REV	DATE	CONTENTS	REVD BY	CHKD BY	CHKD BY	APPD BY
▽▽	12.5S							
▽▽▽	3.2S							
▽▽▽▽	0.4S							

## Class I Division 1

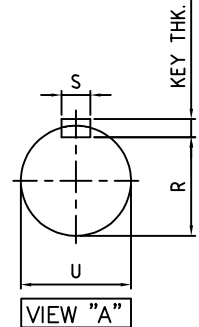
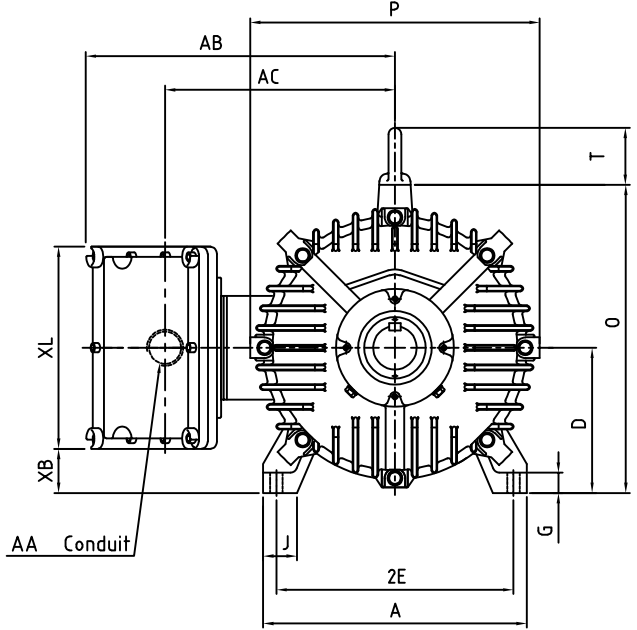
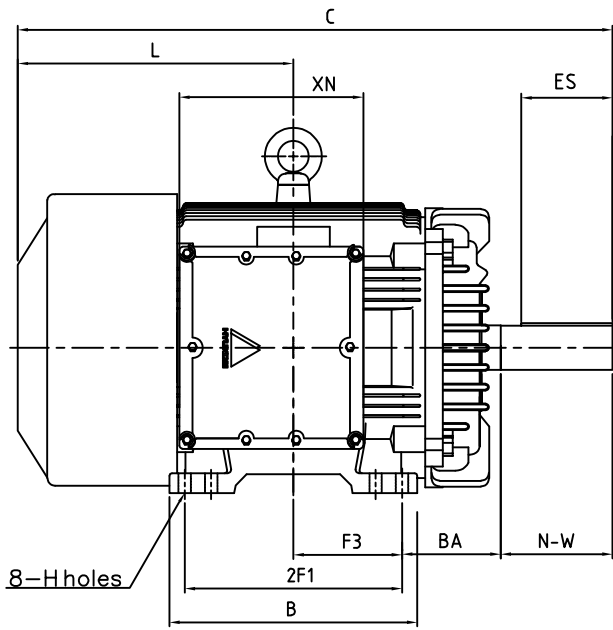

### DIMENSIONS

MOUNTING									CONDUIT BOX						APPROX. WGT.(LB)
A	B	2E	2F1	2F2	F3	G	J	H	AA	AB	AC	XB	XL	XN	
20.00	18.81	18.00	16.50	-	8.248	1.53	2.56	0.81	3.00	24.01	18.30	3.34	15.35	13.97	2P: 2249 or 4P: 2293 or 6P: 2293

OVERALL							SHAFT						KEY	BEARING	
BA	C	D	L	O	P	T	U	N-W	KEYWAY			THK.	DRIVE END	OPP. DRIVE END	
									R	ES	S				
7.50	45.15	11.00	20.92	23.38	21.97	4.33	3.375	8.50	2.880	6.93	0.875	0.875	NU318 or 6318C3	6314C3	

### NOTE

1. Dimension "D" tolerance : +0.00inch - 0.03inch (143T-365T) ; +0.000inch - 0.06inch (404T-449T)
2. Dimension "U" tolerance : +0.000inch - 0.005inch (143T-215T), +0.000inch - 0.001inch (254T-449T)
3. Dimension "R" tolerance : +0.000inch - 0.015inch

APPD BY	S.Y.KIM	UNIT	inch	SUBJECT	445T	DWG SIZE	A4 ( 1:15 )
CHKD BY	R.G.KIM	SCALE	1/15	TITLE	OUTLINE	REF. NO	Sheet No. of
CHKD BY		PROJEC'N	3rd Angle				
DSND BY	J.H.JEON	DATE	2021-04-19				
				DWG NO	LM-U0445B3TL001	Revision No.	0

**Cls. I Div. 1**

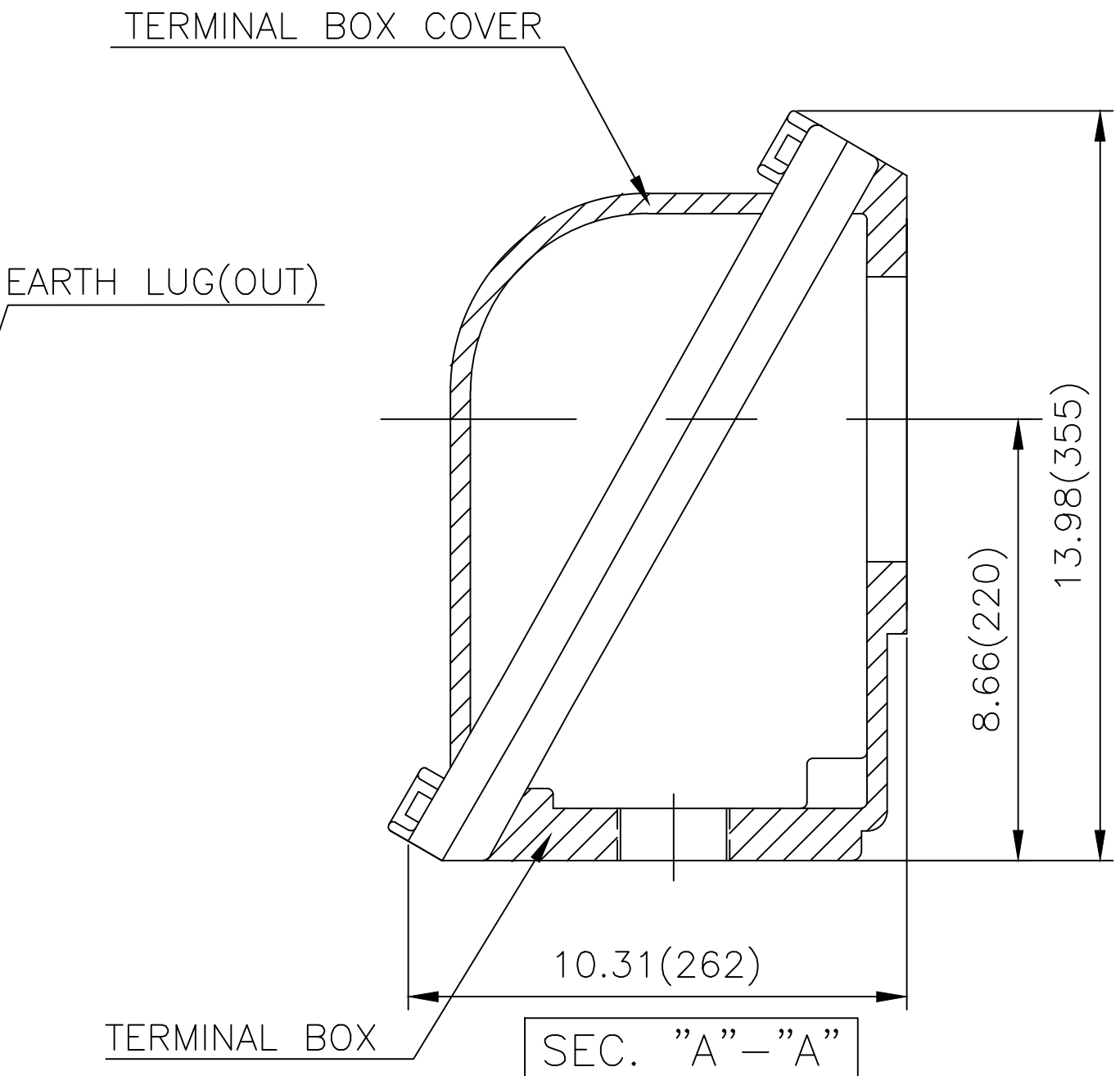
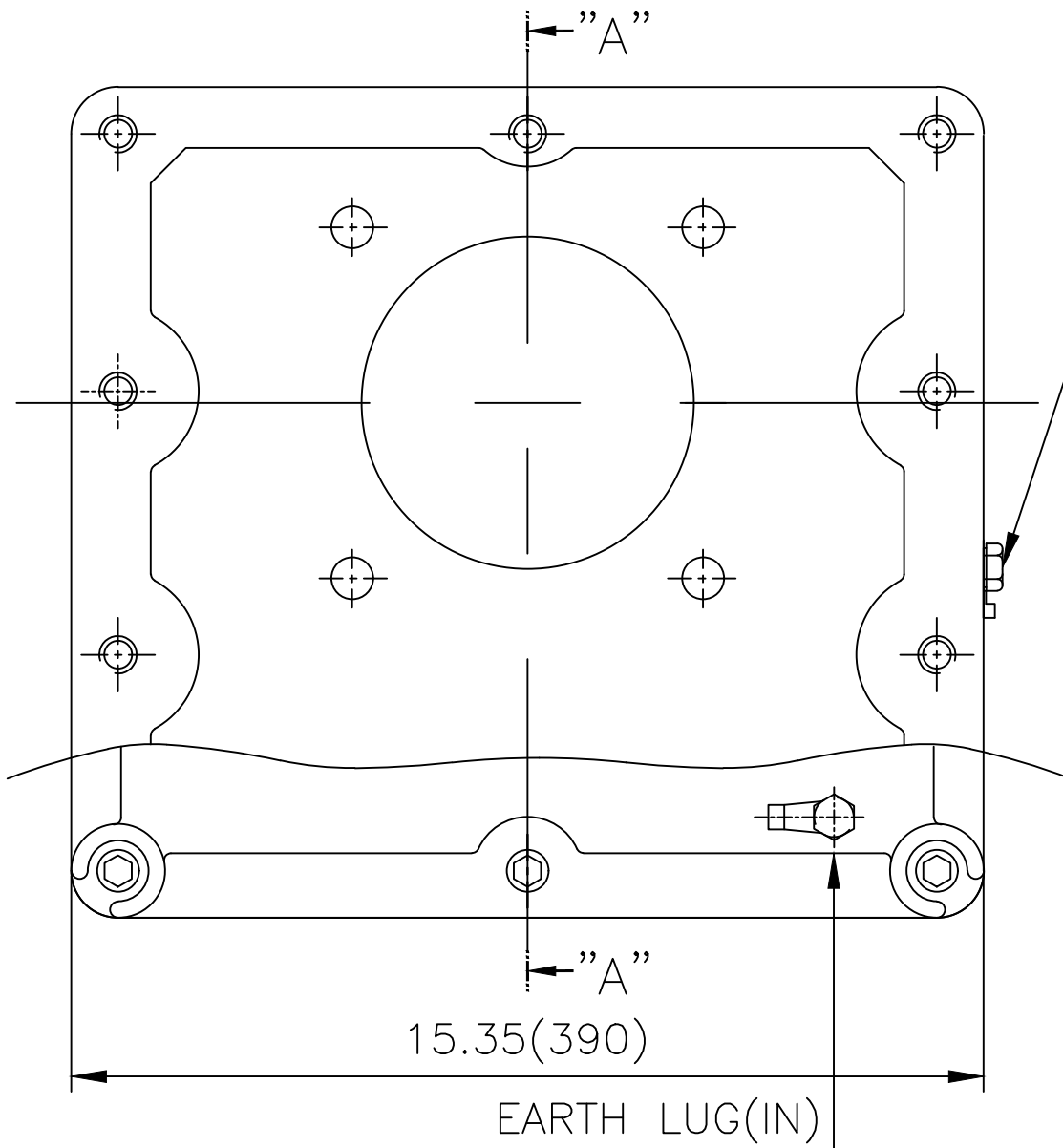

▽	50S
▽▽	12.5S
▽▽▽	3.2S
▽▽▽▽	0.4S

REV	DATE	CONTENTS	REVD BY	CHKD BY	CHKD BY	APPD BY

일반가공공차		일반제관공차	
1-4	±0.1	6-30	±0.5
4-18	±0.2	30-120	±0.8
18-63	±0.3	120-315	±1.2
63-250	±0.5	315-1000	±2.0
250-	±0.8	1000-	±3.0

Q'TY	DESCRIPTION	MATERIAL	DIMENSION	WEIGHT	PART NO.	REMARK	NO.
APPD BY	S.Y.KIM	UNIT	inch(mm)	SUBJECT	NEMA FR. 400~440(CAST IRON)	DWG SIZE	A3 ( 1:3 )
CHKD BY	R.G.KIM	SCALE	1/3	TITLE	MAIN TERMINAL BOX ASS'Y		
CHKD BY		PROJEC'N	3rd Angle	REF. NO		Sheet No.	of
DSND BY	김은진	DATE	2023-11-08	DWG NO	3M-248636	Revision No.	0

