

Customer :  
Project Name :  
Project No. :  
Revision No. :

# SPECIFICATION for INDUCTION MOTOR



0		For Bidding			
No.	DATE	DESCRIPTION	PREPARED BY	CHECKED BY	APPROVED BY



# AC INDUCTION MOTOR DATA SHEET

## IEEE841 TYPE

Catalog No.	IEEE60-36-364TSCRD	Item No.	Rev. No.	[      ]
Project Name		Project No.	Quantity	sets

GENERAL SPECIFICATION			PERFORMANCE DATA			
Frame Size	364TSC		Rated Output	45 kW		60 HP
Type	PJP		Number of Poles	2		
Enclosure(Protection)	Totally Enclosed / IP55		Rotor Type	Squirrel Cage		
Method of Cooling	IC411(FC)		Starting Method*	D.O.L		
Rated Frequency	60 Hz		Rated Voltage	575 V	460 V	230 V
Number of Phases	3		Current	Full Load	52.5 A	65.6 A
Insulation Class	F			Locked-rotor**	680 %	680 %
Temp. Rise at full load (by resistance method)			Efficiency			
at 1.0 S.F	80 deg. C		50% Load		91.1 %	
Motor Location	<input type="checkbox"/> Indoor <input type="checkbox"/> Outdoor		75% Load		93.1 %	
Altitude	Less than 1,000 meter		100% Load		94.1 %	
Relative Humidity	Less than 80 %		Power Factor(p.u)			
Ambient Temp.	40 deg. C (Max.)		50% Load		0.765	
Duty Type	Continuous ( S1 )		75% Load		0.865	
Service Factor	1.15		100% Load		0.915	
Mounting	B5		Speed at Full Load	3570 r.p.m		
Bearing	Type	Anti-Friction	Torque			
	DE/N-DE	6213C3 / 6213C3	Full Load		88.8 lb.ft	
	Lubricant	Grease(Polyrex-EM)	Locked-rotor**		140 %	
External Thrust	Not applicable		Breakdown**		220 %	
Coupling Method	<input checked="" type="checkbox"/> Direct <input type="checkbox"/> V-belt		Moment of Inertia (J)			
Shaft Extension	Single		Load(Max.)		112.720 lb.ft2	
Terminal Box	Main	Cast Iron	Motor		9.280 lb.ft2	
	Aux.	No	Sound Pressure Level (No-load & mean value at 1m from motor)			
	Location	Refer to Outline Drawing			82 dB(A)	
Application			Vibration		3.8 mm/sec (peak)	
Area classification	Hazardous		Permissible number of consecutive starts		Cold 3 times Hot 2 times	
Type of Ex-Protection	Class I&II, Division 2		Paint	Munsell No.	7.5BG6/1.5	
Applicable Standard	IEEE841, NEMA MG1, CSA C390					

ACCESSORIES

SUBMITTAL DRAWING		
Outline Dimension Drawing	Motor Weight(Approx.)	
B5	LM-I1364C5CL001	870 lb.

**REMARK**

1. Premium efficiency according to NEMA MG1
2. Inverter Duty @ 1.0 Service Factor & F Temperature rise
  - 10:1 VT (20:1 VT at 50% load)
  - 10:1 CT
  - CHP up to 1.5 times base speed, NEMA MG1 Part31
3. CSA Certification
  - Class I, Division 2, Group A, B, C & D
  - Class II, Division 2 Group E, F & G (Group E : up to 320Fr.)
4. Service Factor 1.15 and Temperature rise B are applicable under the condition of sine wave power.
5. Service Factor 1.25 is applicable to motors of 100HP or less with temperature rise F & Non-Hazardous.

SPARE PARTS

Date	DSND	CHKD	CHKD	APPD
2024-07-13	S.H. Lee	I.K. Kim	R.G. Kim	S.W. Kim

[Note] Others not mentioned in this data sheet shall be in accordance with maker standard.  
 Above technical data are only design values and shall be guaranteed with tolerance of applicable standard.  
 Inspection and performance test shall be done according to maker standard, if not mentioned.  
 \* In case of Inverter-Fed Motor, performance data is based on sine wave tests. It may be different from test data of Inverter combined motor.  
 \*\* Data is based on rated voltage & frequency and is expressed as a percentage of full-load value.

1	2	3	4
REV	DATE	CONTENTS	REVD BY   CHKD BY   CHKD BY   APPD BY

4.72

## CROWN TRITON

Premium Efficiency AC 3 Phase Motor



60HP	2P	460V	Cat. No.	IEEE60-36-364TSCRD				
Model	HLS364PR02		INS. Class	F	HD-F1	Amps	65.6	
Type	HLS	Duty	CONT	Code	G	Amb.	40°C	
Frame	364TSC	Encl.	TEFC	S.F.	1.15	RPM	3570	
Bearing	Drive	6213C3		S.F.1.00 (10:1 C.T., 20:1 V.T., NEMA-MG1 Part31)		3/4 Eff.	93.1%	
	Opp.	6213C3				NEMA Design	B	
Usable at	50Hz 50HP 380V 65.6A 2968rpm S.F.: 1.0 Eff.: 93.7% Code: G							
	50Hz 50HP 400/415V 62.3/60.1A 2972/2975rpm S.F.: 1.0 Eff.: 93.9/94.1% Code: G/H							
CSA Certified for	Model	LATER		Type	PJP	Temp. Code		
	CLASS I, Div. 2, Gr. A, B, C & D		CLASS II, Div. 2, Gr. E, F & G (Gr. E : Up to 320FR)		Frame	140~320FR	360~400FR	440FR
	CLASS I, Zone 2, Gr. IIA, IIB, & IIC				Amb. 40°C	T3C (160°C)	T3B (165°C)	T3A (180°C)
					Amb. 55°C	T3A (180°C)	T3A (180°C)	T3 (200°C)
No.	-		Date	-		Weight	870 lb	

**IEEE Std 841-2021**

4M-135701

**MARINE DUTY IEEE45**

Made in Korea H1



2.36

APPD BY	S.Y.KIM	UNIT	INCH	SUBJECT	CSA Class I, Division2 IEEE841 (HL)	DWG SIZE
CHKD BY	I.K.KIM	SCALE	NONE			A4 ( 1:1 )
CHKD BY	R.G.KIM	PROJEC'N	3rd Angle	TITLE <b>NAMEPLATE DRAWING</b>		
DSND BY	S.H.LEE	DATE	2024.06.07			
				REF. NO	<b>4M-135701</b>	Sheet No. of
				DWG NO	<b>NP-IEEE60-36-364TSCRD</b>	Revision No. <b>0</b>

Type :	PJP
Full Load Torque :	88.8 lb.ft
Load moment of Inertia (J) :	112.720 lb.ft2
Motor moment of Inertia (J) :	9.280 lb.ft2

45kW 60HP	2 P	60 Hz
Speed at Full Load : 3570 RPM		
Rated Voltage	575V	460V 230V
Full Load Current	52.5A	65.6A 131.2A

SPEED VS TORQUE & CURRENT CURVE

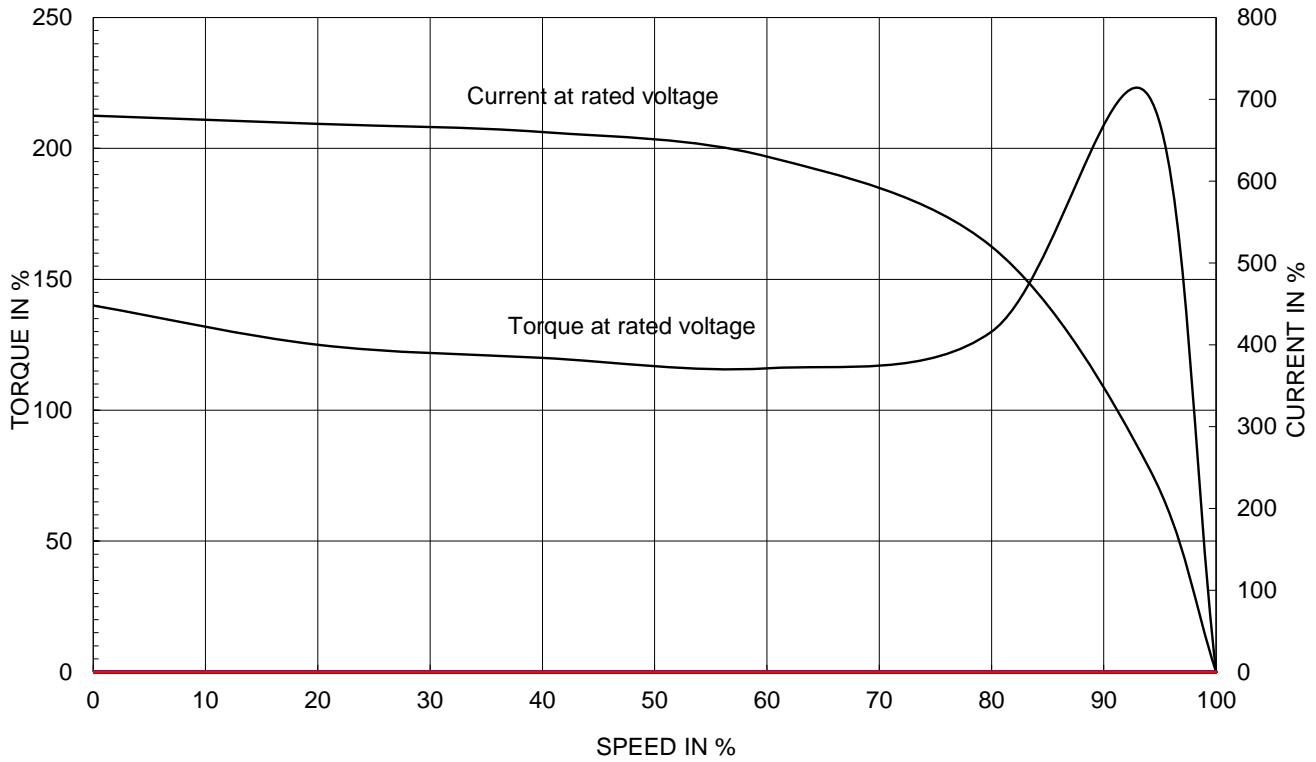

OUTPUT VS EFF., P.F & CURRENT CURVE

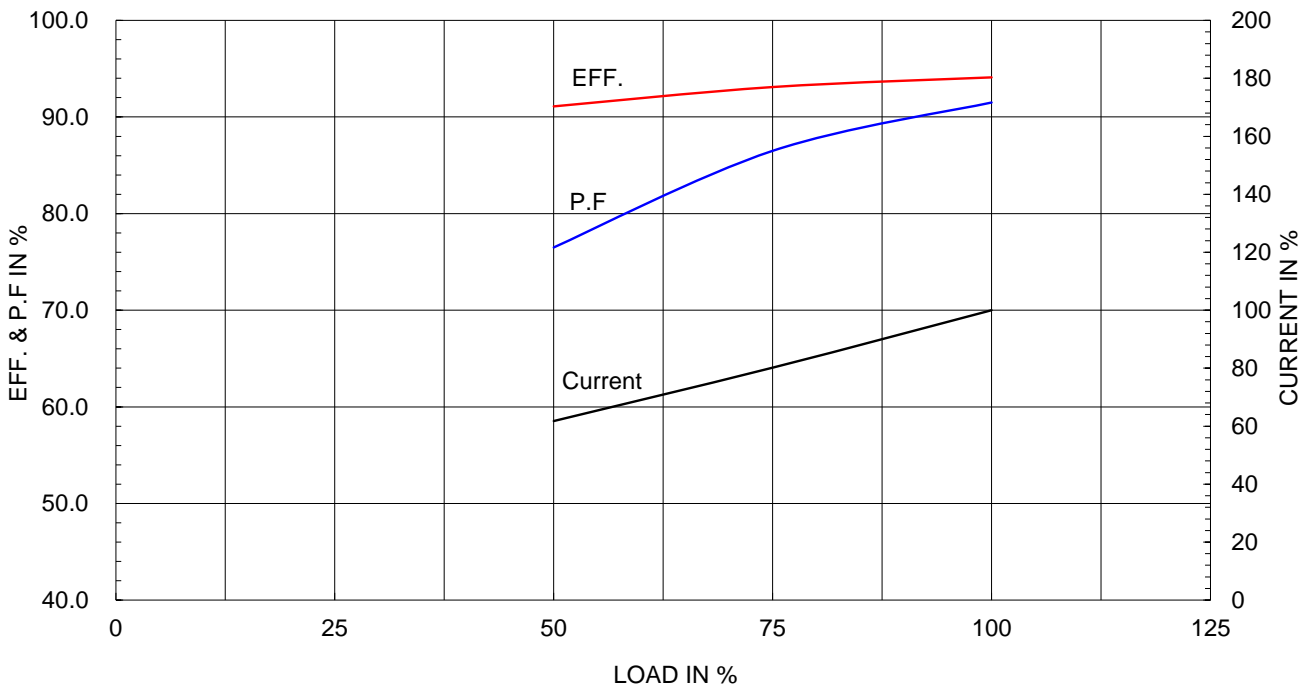

본 도면은 HD현대일렉트릭(주) 재산이며 허가없이 복사할 수 없음 (취급주의)

THIS DRAWING IS PROPRIETARY TO HYUNDAI ELECTRIC. NO PART OF THIS DRAWING MAYBE REPRODUCED WITHOUT THE PERMISSION OF HYUNDAI ELECTRIC.

▽	50S	REV	DATE	CONTENTS	REVD BY	CHKD BY	CHKD BY	APPD BY
▽▽	12.5S							
▽▽▽	3.2S							
▽▽▽▽	0.4S							

**IEEE841**

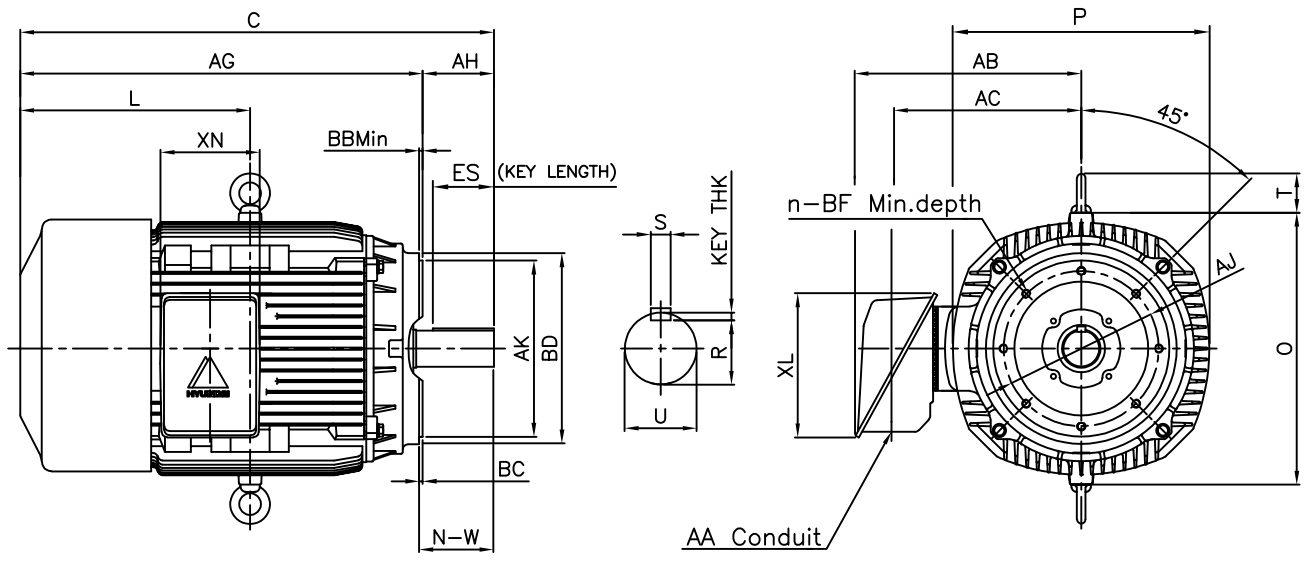

DIMENSIONS

Unit : inch

C - F A C E									CONDUIT BOX					APPROX. WGT.(LB)
AJ	AK	BB Min	BC	BD	BF	BF depth	n	AH	AA	AB	AC	XL	XN	
11.00	12.50	0.25	0.25	13.54	5/8-11	0.94	8	3.50	3.00	17.13	13.82	10.24	7.09	870

O V E R A L L					S H A F T						KEY	BEARING	
C	L	O	P	T	AG	U	N-W	KEYWAY			THK.	DRIVE END	OPP. DRIVE END
								R	ES	S			
33.06	17.32	19.29	17.75	2.80	29.56	1.875	3.75	1.591	2.03	0.500	0.500	6213C3	6213C3

**NOTE**

- 1.Dimension "U" tolerance : +0.000inch ~ -0.0005inch (143TC-215TC): +0.000inch ~ -0.001inch (254TC-449TC)
- 2.Dimension "R" tolerance : +0.000inch ~ - 0.015inch
- 3.Dimension "AK" tolerance : +0.000inch ~ -0.003inch (143TC-286TC): +0.000inch ~ -0.005inch (324TC-449TC)

APPD BY	S.Y.KIM	UNIT	INCH	SUBJECT	NEMA 364TSC	DWG SIZE	A4 ( 1:1 )		
CHKD BY	R.G.KIM	SCALE	NONE	TITLE	OUTLINE	REF. NO	350A8513BA		
CHKD BY	Y.H.BAE	PROJEC'N	3각법(3rd Angle)					Sheet No.	of
DSND BY	H.K.LEE	DATE	2021-04-30						
				DWG NO	LM-I1364C5CL001	Revision No.	0		



HD HYUNDAI ELECTRIC

본 도면은 HD현대일렉트릭(주) 재산이며 허가없이 복사할 수 없음 (취급주의)

THIS DRAWING IS PROPRIETARY TO HYUNDAI ELECTRIC. NO PART OF THIS DRAWING MAY BE REPRODUCED WITHOUT THE PERMISSION OF HYUNDAI ELECTRIC.

# Cls. I&II, Div. 2 IEEE 841

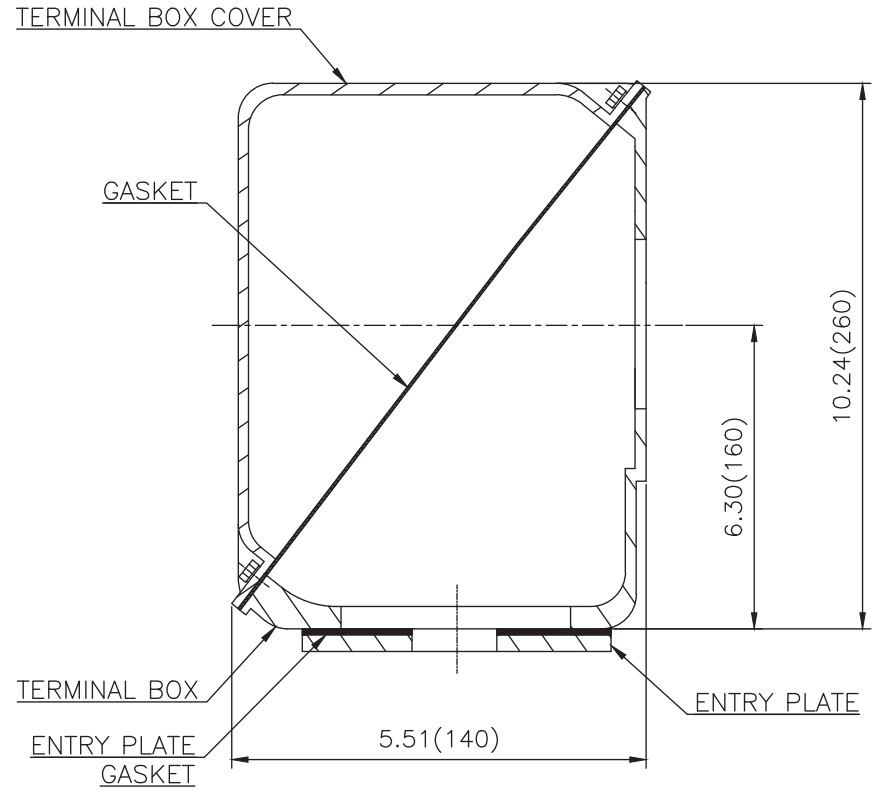
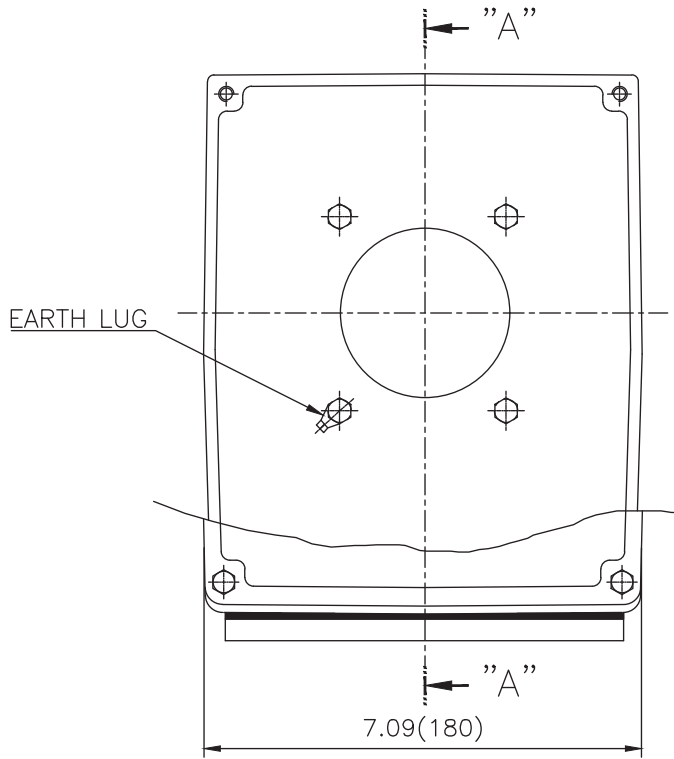

SEC. "A" - "A"

▽	50S
▽▽	12.5S
▽▽▽	3.2S
▽▽▽▽	0.4S

REV	DATE	CONTENTS	REVD BY	CHKD BY	CHKD BY	APPD BY

일반가공공차		일반재공공차	
1-4	±0.1	6-30	±0.5
4-18	±0.2	30-120	±0.8
18-63	±0.3	120-315	±1.2
63-250	±0.5	315-1000	±2.0
250-	±0.8	1000-	±3.0

Q'TY	DESCRIPTION	MATERIAL	DIMENSION	WEIGHT	PART NO.	REMARK	NO.
APPD BY	S.Y.KIM	UNIT	inch(mm)	SUBJECT	FR.360 (CAST IRON)	DWG SIZE	A3 (1:1.2)
CHKD BY		SCALE	1/1.2	TITLE			
CHKD BY	R.G.KIM	PROJEC'N	3rd Angle	MAIN TERMINAL BOX ASS'Y			
DSND BY	내승희	DATE	2023-10-19	REF. NO		Sheet No.	of
				DWG NO	3M-248450	Revision No.	0