

Customer :
Project Name :
Project No. :
Revision No. :

SPECIFICATION for INDUCTION MOTOR



0		For Bidding			
No.	DATE	DESCRIPTION	PREPARED BY	CHECKED BY	APPROVED BY



AC INDUCTION MOTOR DATA SHEET

IEEE841 TYPE

Catalog No.	IEEE500-36-5010SC-IBSHSP	Item No.	Rev. No. []
Project Name		Project No.	Quantity sets

GENERAL SPECIFICATION		PERFORMANCE DATA			
Frame Size	5010SC	Rated Output	375 kW 500 HP		
Type	PJP	Number of Poles	2		
Enclosure(Protection)	Totally Enclosed / IP55	Rotor Type	Squirrel Cage		
Method of Cooling	IC411(FC)	Starting Method*	D.O.L		
Rated Frequency	60 Hz	Rated Voltage	575 V	460 V	230 V
Number of Phases	3	Current	Full Load	436.7 A	545.9 A
Insulation Class	F		Locked-rotor**	725 %	725 %
Temp. Rise at full load (by resistance method)		Efficiency			
at 1.0 S.F	80 deg. C	50% Load		92.8 %	
Motor Location	<input type="checkbox"/> Indoor <input type="checkbox"/> Outdoor	75% Load		94.8 %	
Altitude	Less than 1,000 meter	100% Load		95.8 %	
Relative Humidity	Less than 80 %	Power Factor(p.u)			
Ambient Temp.	40 deg. C (Max.)	50% Load		0.750	
Duty Type	Continuous (S1)	75% Load		0.850	
Service Factor	1.15	100% Load		0.900	
Mounting	B35	Speed at Full Load	3570 r.p.m		
Bearing	Type	Anti-Friction	Torque		
	DE/N-DE	6315C3 / 6315C3-INS.	Full Load	740.0 lb.ft	
	Lubricant	Grease(Polyrex-EM)	Locked-rotor**	145 %	
External Thrust	Not applicable	Breakdown**	240 %		
Coupling Method	<input checked="" type="checkbox"/> Direct <input type="checkbox"/> V-belt	Moment of Inertia (J)			
Shaft Extension	Single	Load(Max.)	381.000 lb.ft2		
Terminal Box	Main	Cast Iron	Motor	76.418 lb.ft2	
	Aux.	Yes	Sound Pressure Level (No-load & mean value at 1m from motor)		
Location	Refer to Outline Drawing	87 dB(A)			
Application		Vibration			
Area classification	Hazardous	3.8 mm/sec (peak)			
Type of Ex-Protection	Class I&II, Division 2	Permissible number of consecutive starts	Cold	2 times	
Applicable Standard	IEEE841, NEMA MG1, CSA C390	Hot	1 time		
		Paint	Munsell No.	7.5BG6/1.5	

ACCESSORIES
*. Space Heater : 1EA/Motor

SPARE PARTS
1. Spare Axial Fan (C.W Direction)

SUBMITTAL DRAWING		
Outline Dimension Drawing	Motor Weight(Approx.)	
B35	LM-I0511C4CE001	4940 lb.

REMARK

1. Premium efficiency according to NEMA MG1
2. Inverter Duty @ 1.0 Service Factor & F Temperature rise
 - . 10:1 VT (20:1 VT at 50% load)
 - . 10:1 CT
 - . CHp up to 1.5 times base speed, NEMA MG1 Part31
3. NDE side : Insulated bearing
4. CSA Certification
 - . Class I, Division 2, Group A, B, C & D; Temp code : T3
 - . Class II, Division 2 Group F & G; Temp code : T3
5. Shaft material : AISI4140
6. Uni-directional CCW viewed from drive end.

Date	DSND	CHKD	CHKD	APPD
2024-07-13	S.H. Lee	I.K. Kim	R.G. Kim	S.W. Kim

[Note] Others not mentioned in this data sheet shall be in accordance with maker standard.
 Above technical data are only design values and shall be guaranteed with tolerance of applicable standard.
 Inspection and performance test shall be done according to maker standard, if not mentioned.
 * In case of Inverter-Fed Motor, performance data is based on sine wave tests. It may be different from test data of Inverter combined motor.
 ** Data is based on rated voltage & frequency and is expressed as a percentage of full-load value.

1	2	3	4
REV	DATE	CONTENTS	REVD BY

4.72

CROWN TRITON

Premium Efficiency AC 3 Phase Motor



500HP	2P	460V	Cat. No.	IEEE500-36-5010SC-IBSHSP			
Model	LATER		INS. Class	F	Amps	545.9	
Type	PJP	Duty	CONT	Code	H	Amb.	40°C
Frame	5010SC	Encl.	TEFC	S.F.	1.15	RPM	3570
Bearing	Drive	6315C3		S.F.1.00 (10:1 C.T., 20:1 V.T., NEMA-MG1 Part31)		3/4 Eff.	94.8%
	Opp.	6315C3-INS.				NEMA Design	B Torque
Usable at							
CSA Certified for	CLASS I, Div. 2, Gr. A, B, C & D		CLASS II, Div. 2, Gr. F & G		Temp. Code (sine wave)	Frame	L440FR - 500FR
	CLASS I, Zone 2, Gr. IIA, IIB, & IIC					Amb. 40°C	T3 (200°C)
						Amb. 55°C	T3 (200°C)
No.	-		Date	-		Weight	4940 lb

IEEE Std 841-2021

4M-136054

MARINE DUTY IEEE45

Made in Korea H1



2.36

APPD BY	S.Y.KIM	UNIT	INCH	SUBJECT	CSA Class I, Division2 IEEE841 (XL)	DWG SIZE
CHKD BY	I.K.KIM	SCALE	NONE			A4 (1:1)
CHKD BY	R.G.KIM	PROJEC'N	3rd Angle	TITLE NAMEPLATE DRAWING		
DSND BY	S.H.LEE	DATE	2024.06.07			
				REF. NO	4M-136054	Sheet No. of
				DWG NO	NP-IEEE500-36-5010SC-IBSHSP	Revision No. 0



PERFORMANCE CURVE

CURVE NO.
PC-IEEE500-36-5010SC-IBSHSP

Type :	PJP
Full Load Torque :	740.0 lb.ft
Load moment of Inertia (J) :	381.000 lb.ft2
Motor moment of Inertia (J) :	76.418 lb.ft2

375kW	500HP	2 P	60 Hz
Speed at Full Load :			3570 RPM
Rated Voltage	575V	460V	230V
Full Load Current	436.7A	545.9A	#####

SPEED VS TORQUE & CURRENT CURVE

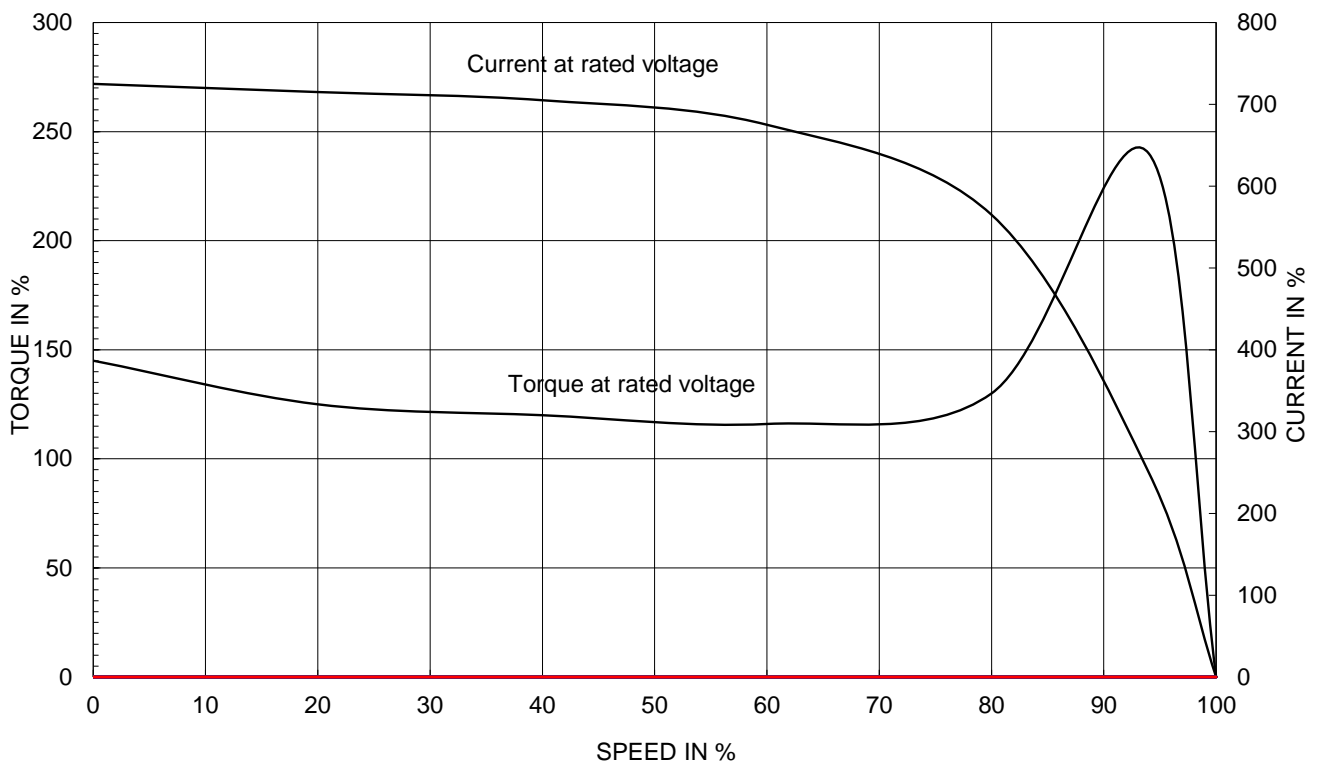

OUTPUT VS EFF., P.F & CURRENT CURVE

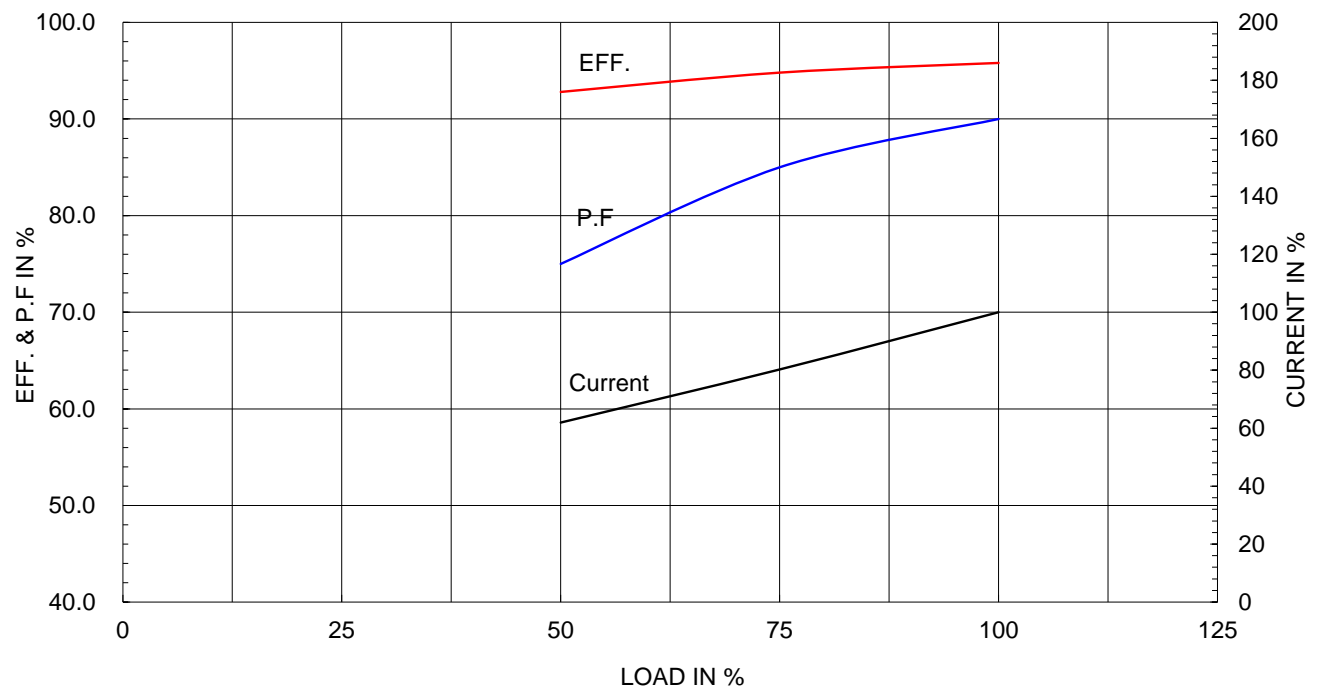

본 도면은 HD현대일렉트릭(주) 재산이며 허가없이 복사할 수 없음 (취급유의)

THIS DRAWING IS PROPRIETARY TO HYUNDAI ELECTRIC. NO PART OF THIS DRAWING MAYBE REPRODUCED WITHOUT THE PERMISSION OF HYUNDAI ELECTRIC.

1	2	3	4
▽	50S	REV	DATE
▽▽	12.5S		
▽▽▽	3.2S		
▽▽▽▽	0.4S		

IEEE841

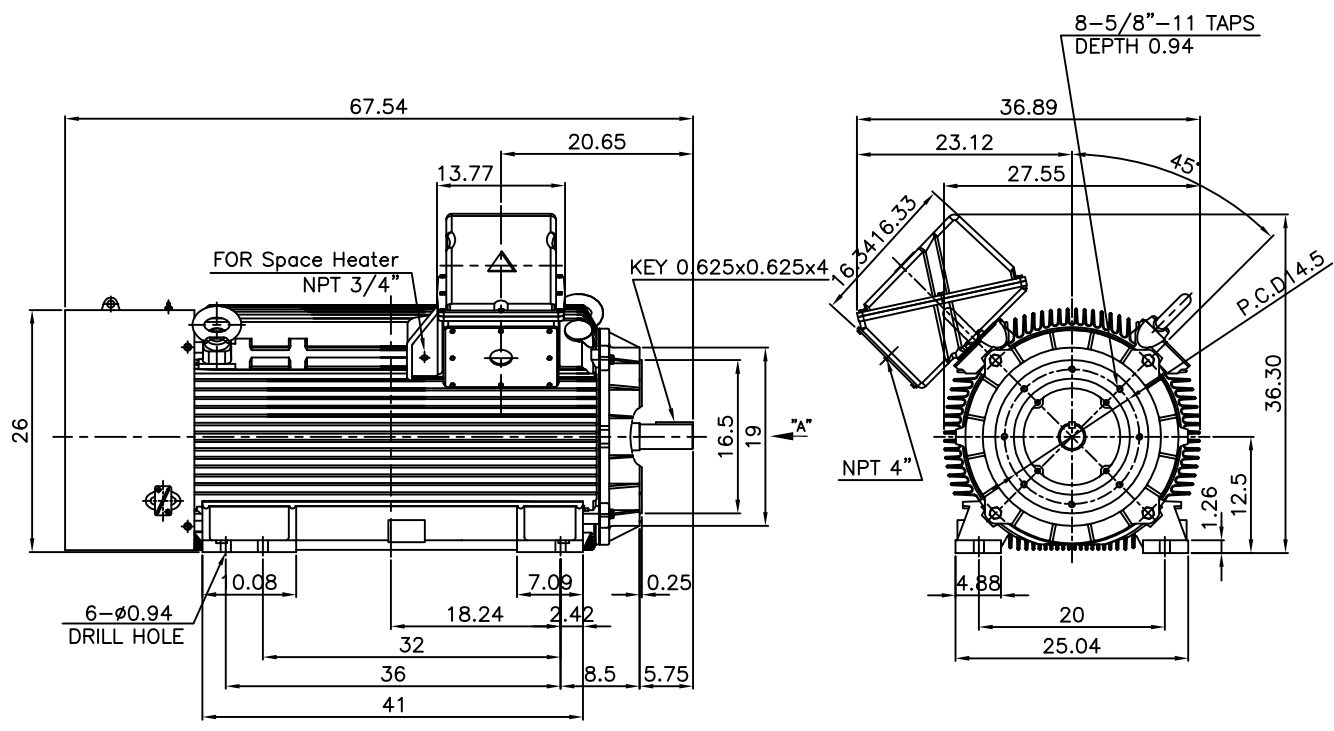

NOTE

1.TOLERANCE :

CENTER HEIGHT	12.5	+0.000	-0.060
RABBET DIAMETER	∅16.5	+0.000	-0.005
SHAFT DIAMETER	∅2.625	+0.000	-0.001
KEYWAY WIDTH	0.625	+0.002	-0.000

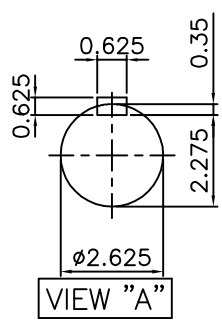

APPD BY	S.Y.KIM	UNIT	INCH	SUBJECT	Fr.5010/5011TSC	DWG SIZE	A4 (1:20)
CHKD BY	O.J.KIM	SCALE	1/20	TITLE	CAST IRON T-BOX OUTLINE	Sheet No. of	
CHKD BY	R.G.KIM	PROJEC'N	3각법 (3rd Angle)	REF. NO		Revision No. 0	
DSND BY	H.K.LEE	DATE	2021-04-27	DWG NO	LM-I0511C4CE001	Revision No. 0	

**Cls. I&II, Div. 2
IEEE 841**



SEC. "A" - "A"

REV	DATE	CONTENTS	REVD BY	CHKD BY	CHKD BY	APPD BY

APPD BY	S.Y.KIM	UNIT	inch(mm)	SUBJECT	FR. L440 (CAST IRON)	DWG SIZE
CHKD BY		SCALE	1/3.5	TITLE	MAIN TERMINAL BOX ASS'Y	A3 (1:3.5)
CHKD BY	R.G.KIM	PROJEC'N	3rd Angle			
DSND BY	최승희	DATE	2023-10-19			
				REF. NO		Sheet No. of
				DWG NO	3M-248452	Revision No. 0

**Cls. I&II, Div. 2
IEEE 841**

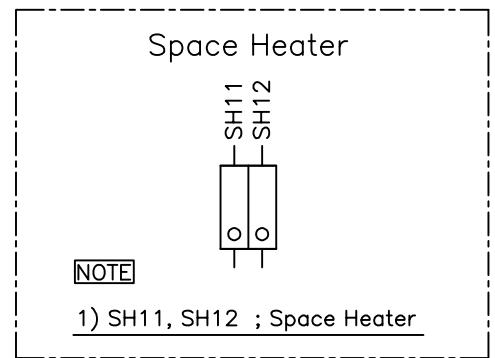
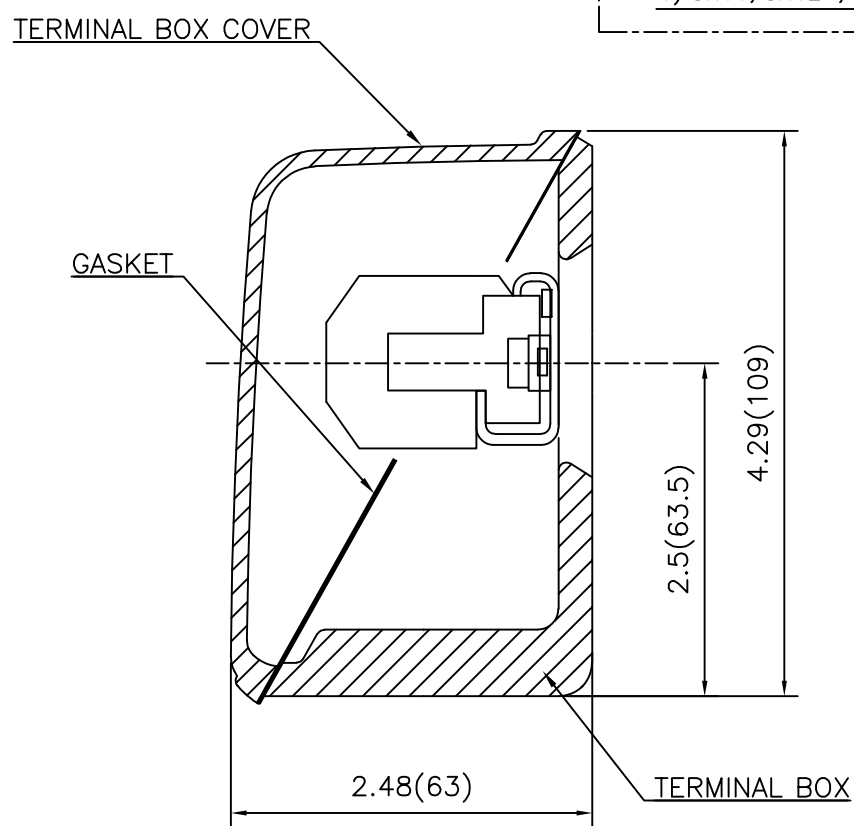
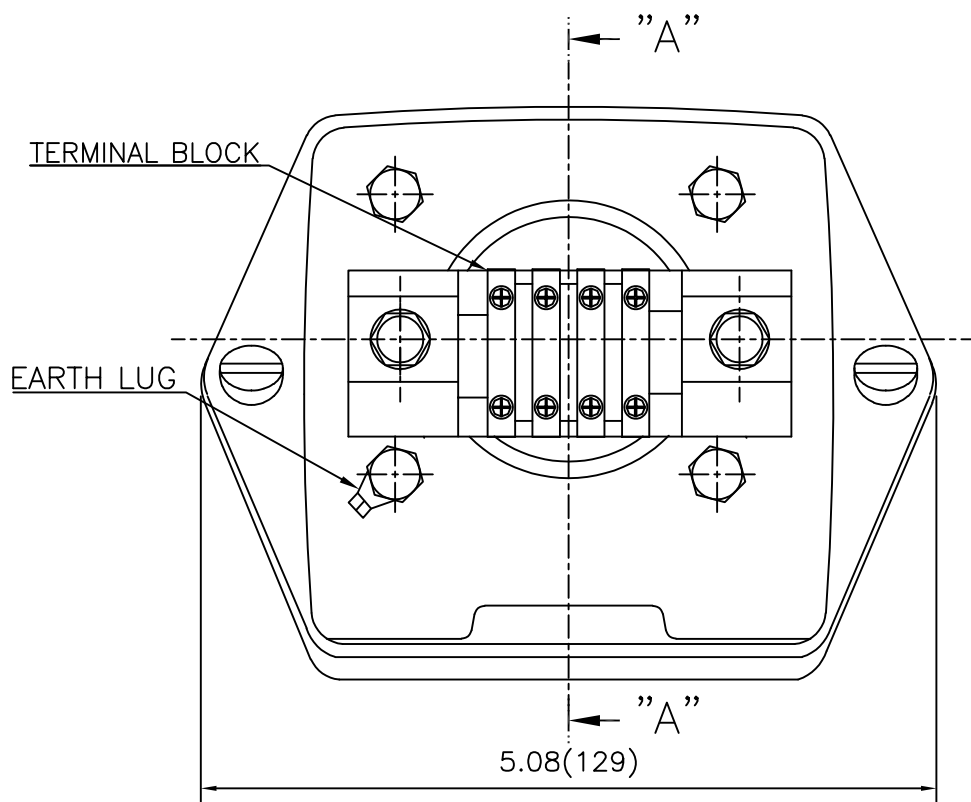

REV	DATE	CONTENTS	REVD BY	CHKD BY	CHKD BY	APPD BY

APPD BY	S.Y.KIM	UNIT	inch(mm)	SUBJECT	FR.180 (CAST IRON)	DWG SIZE	A3 (1:1.1)
CHKD BY		SCALE	1/1	TITLE	SUB. TERMINAL BOX ASS'Y		
CHKD BY	R.G.KIM	PROJEC'N	3rd Angle	REF. NO		Sheet No.	of
DSND BY	배승희	DATE	2024-01-18	DWG NO	3M-165278	Revision No.	0

