

Customer :  
Project Name :  
Project No. :  
Revision No. :

# SPECIFICATION for INDUCTION MOTOR



0		For Bidding			
No.	DATE	DESCRIPTION	PREPARED BY	CHECKED BY	APPROVED BY



# AC INDUCTION MOTOR DATA SHEET

## IEEE841 TYPE

Catalog No.	IEEE500-36-5010S-IBBRSRSHSP	Item No.		Rev. No.	[ ]
Project Name		Project No.		Quantity	sets

GENERAL SPECIFICATION			PERFORMANCE DATA			
Frame Size	5010S		Rated Output	375 kW 500 HP		
Type	PJP		Number of Poles	2		
Enclosure(Protection)	Totally Enclosed	/ IP55	Rotor Type	Squirrel Cage		
Method of Cooling	IC411(FC)		Starting Method*	D.O.L		
Rated Frequency	60 Hz		Rated Voltage	575 V	460 V	230 V
Number of Phases	3		Current	Full Load	436.7 A	545.9 A 1,091.8 A
Insulation Class	F			Locked-rotor**	725 %	725 % 725 %
Temp. Rise at full load (by resistance method)			Efficiency			
at 1.0 S.F	80 deg. C		50% Load		92.8 %	
Motor Location	<input type="checkbox"/> Indoor <input type="checkbox"/> Outdoor		75% Load		94.8 %	
Altitude	Less than 1,000 meter		100% Load		95.8 %	
Relative Humidity	Less than 80 %		Power Factor(p.u)			
Ambient Temp.	40 deg. C (Max.)		50% Load		0.750	
Duty Type	Continuous ( S1 )		75% Load		0.850	
Service Factor	1.15		100% Load		0.900	
Mounting	B3		Speed at Full Load	3570 r.p.m		
Bearing	Type	Anti-Friction	Torque			
	DE/N-DE	6315C3 / 6315C3-INS.	Full Load		740.0 lb.ft	
	Lubricant	Grease(Polyrex-EM)	Locked-rotor**		145 %	
External Thrust	Not applicable		Breakdown**		240 %	
Coupling Method	<input checked="" type="checkbox"/> Direct <input type="checkbox"/> V-belt		Moment of Inertia (J)			
Shaft Extension	Single		Load(Max.)		381.000 lb.ft2	
Terminal Box	Main	Cast Iron	Motor		76.418 lb.ft2	
	Aux.	Yes	Sound Pressure Level (No-load & mean value at 1m from motor)			
	Location	Refer to Outline Drawing			87 dB(A)	
Application			Vibration		3.8 mm/sec (peak)	
Area classification	Hazardous		Permissible number of consecutive starts		Cold 2 times Hot 1 time	
Type of Ex-Protection	Class I&II, Division 2		Paint	Munsell No.	7.5BG6/1.5	
Applicable Standard	IEEE841, NEMA MG1, CSA C390					

ACCESSORIES
*. B.T.D.(Pt 100 Ω at 0°C,Single) : 2EA/Motor
*. W.T.D.(Pt 100 Ω at 0°C) : 2EA/Ph.
*. Space Heater : 1EA/Motor

SPARE PARTS
1. Spare Axial Fan (C.W Direction)

SUBMITTAL DRAWING			
Outline Dimension Drawing		Motor Weight(Approx.)	
B3	LM-I0511B3C7001	4800 lb.	

REMARK
1. Premium efficiency according to NEMA MG1
2. Inverter Duty @ 1.0 Service Factor & F Temperature rise
- . 10:1 VT (20:1 VT at 50% load)
- . 10:1 CT
- . CHp up to 1.5 times base speed, NEMA MG1 Part31
3. NDE side : Insulated bearing
4. CSA Certification
- . Class I, Division 2, Group A, B, C & D; Temp code : T3
- . Class II, Division 2 Group F & G; Temp code : T3
5. Shaft material : AISI4140
6. Uni-directional CCW viewed from drive end.

Date	DSND	CHKD	CHKD	APPD
2024-07-13	S.H. Lee	I.K. Kim	R.G. Kim	S.W. Kim





[Note] Others not mentioned in this data sheet shall be in accordance with maker standard.  
 Above technical data are only design values and shall be guaranteed with tolerance of applicable standard.  
 Inspection and performance test shall be done according to maker standard, if not mentioned.  
 \* In case of Inverter-Fed Motor, performance data is based on sine wave tests. It may be different from test data of Inverter combined motor.  
 \*\* Data is based on rated voltage & frequency and is expressed as a percentage of full-load value.

1	2	3	4
REV	DATE	CONTENTS	REVD BY   CHKD BY   CHKD BY   APPD BY

4.72



**CROWN TRITON**  
Premium Efficiency AC 3 Phase Motor

500HP	2P	460V	Cat. No.	IEEE500-36-5010S-IBBRSRSHSP			
Model	LATER		INS. Class	F	Amps	545.9	
Type	PJP	Duty	CONT	Code	H	Amb.	40°C
Frame	5010S	Encl.	TEFC	S.F.	1.15	RPM	3570
Bearing	Drive	6315C3		S.F.1.00 (10:1 C.T., 20:1 V.T., NEMA-MG1 Part31)		3/4 Eff.	94.8%
	Opp.	6315C3-INS.				NEMA Design	B Torque
Usable at							
CSA Certified for	CLASS I, Div. 2, Gr. A, B, C & D		CLASS II, Div. 2, Gr. F & G		Temp. Code (sine wave)	Frame	L440FR - 500FR
	CLASS I, Zone 2, Gr. IIA, IIB, & IIC					Amb. 40°C	T3 (200°C)
						Amb. 55°C	T3 (200°C)
No.	-	Date	-	Weight	4800 lb		

**IEEE Std 841-2021**  
4M-136054

**MARINE DUTY IEEE45**  
Made in Korea H1



2.36

APPD BY	S.Y.KIM	UNIT	INCH	SUBJECT	CSA Class I, Division2 IEEE841 (XL)	DWG SIZE
CHKD BY	I.K.KIM	SCALE	NONE			A4 ( 1:1 )
CHKD BY	R.G.KIM	PROJEC'N	3rd Angle	TITLE <b>NAMEPLATE DRAWING</b>		
DSND BY	S.H.LEE	DATE	2024.06.07			
				REF. NO	<b>4M-136054</b>	Sheet No. of
				DWG NO	NP-IEEE500-36-5010S-IBBRSRSHSP	Revision No.



# PERFORMANCE CURVE

CURVE NO.

PC-IEEE500-36-5010S-IBBRSRSHSP

Type :	PJP	
Full Load Torque :	740.0	lb.ft
Load moment of Inertia (J) :	381.000	lb.ft2
Motor moment of Inertia (J) :	76.418	lb.ft2

375kW	500HP	2 P	60 Hz
Speed at Full Load :			3570 RPM
Rated Voltage	575V	460V	230V
Full Load Current	436.7A	545.9A	#####

SPEED VS TORQUE & CURRENT CURVE

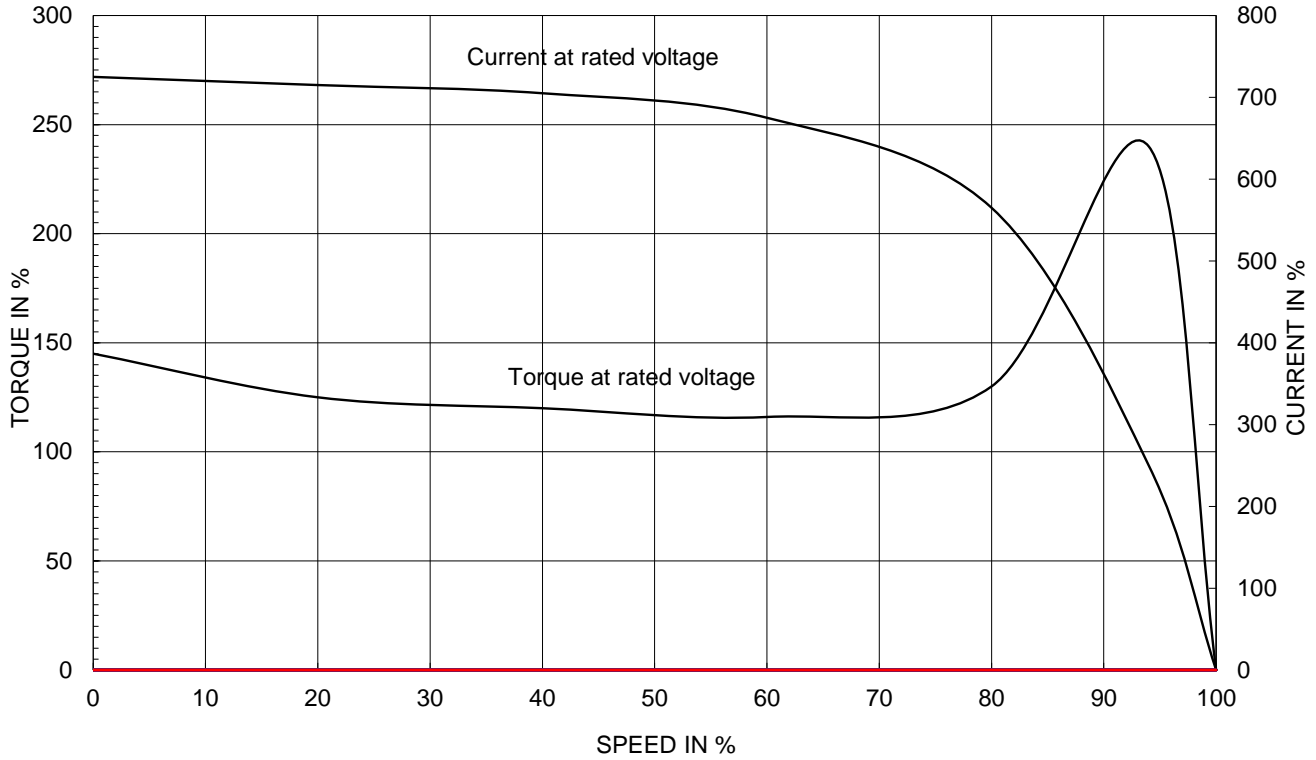

OUTPUT VS EFF., P.F & CURRENT CURVE

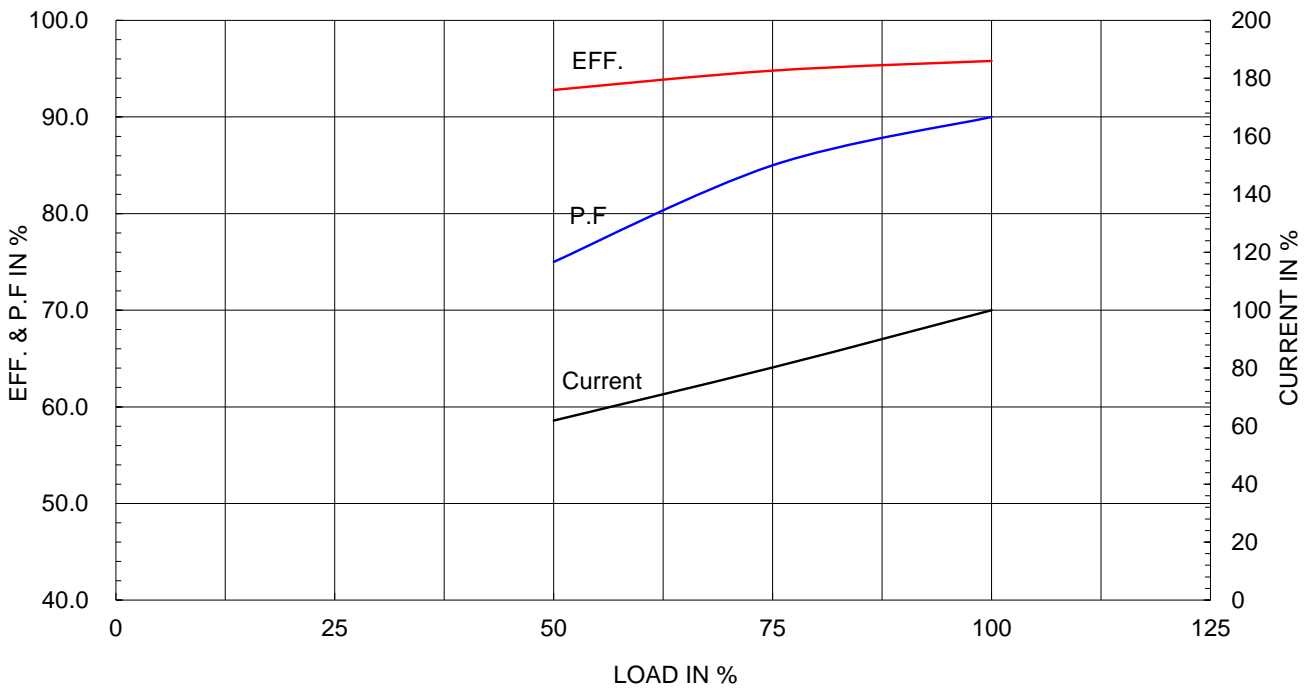

▽	50S	REV	DATE	CONTENTS	REVD BY	CHKD BY	CHKD BY	APPD BY
▽▽	12.5S							
▽▽▽	3.2S							
▽▽▽▽	0.4S							

**IEEE841**

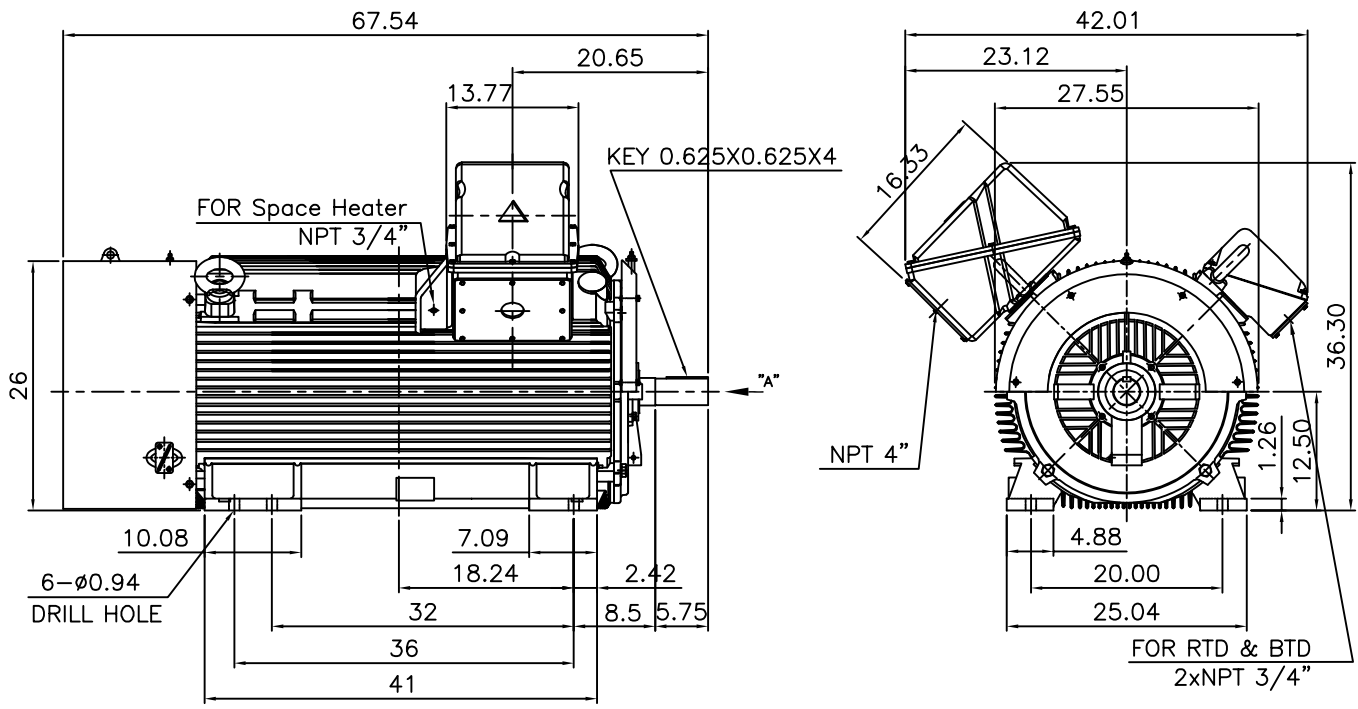

NOTE

1.TOLERANCE :

CENTER HEIGHT	12.5	+0.000	-0.060
SHAFT DIAMETER	ø2.625	+0.000	-0.001
KEYWAY WIDTH	0.625	+0.002	-0.000

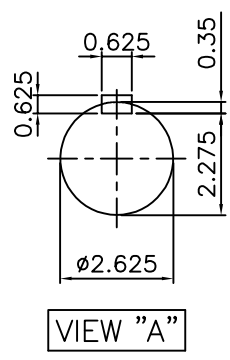

APPD BY	S.Y.KIM	UNIT	INCH	SUBJECT	Fr.5010/5011TS	DWG SIZE	A4 (1:20)
CHKD BY	O.J.KIM	SCALE	1/20	TITLE	CAST IRON T-BOX		
CHKD BY	R.G.KIM	PROJEC'N	3각법(3rd Angle)	<b>OUTLINE</b>			
DSND BY	H.K.LEE	DATE	2021-04-27				
				REF. NO		Sheet No.	of
				DWG NO	LM-I0511B3C7001	Revision No.	0

**Cls. I&II, Div. 2  
IEEE 841**

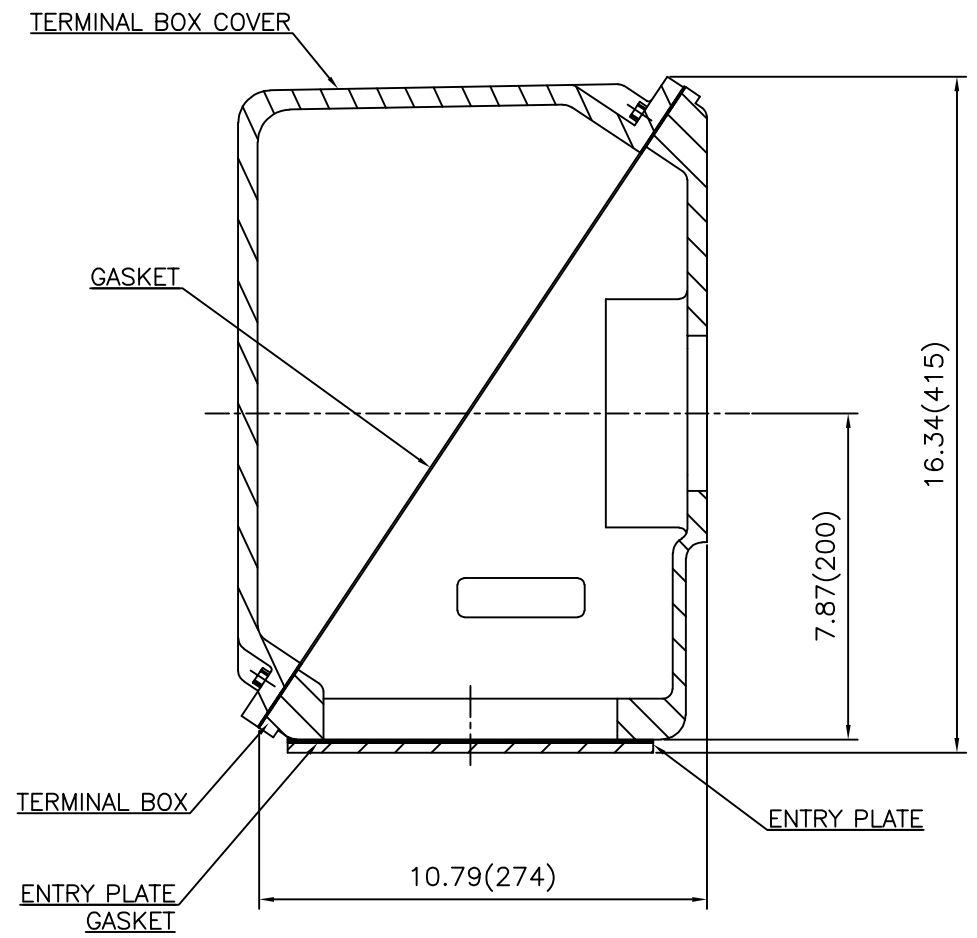
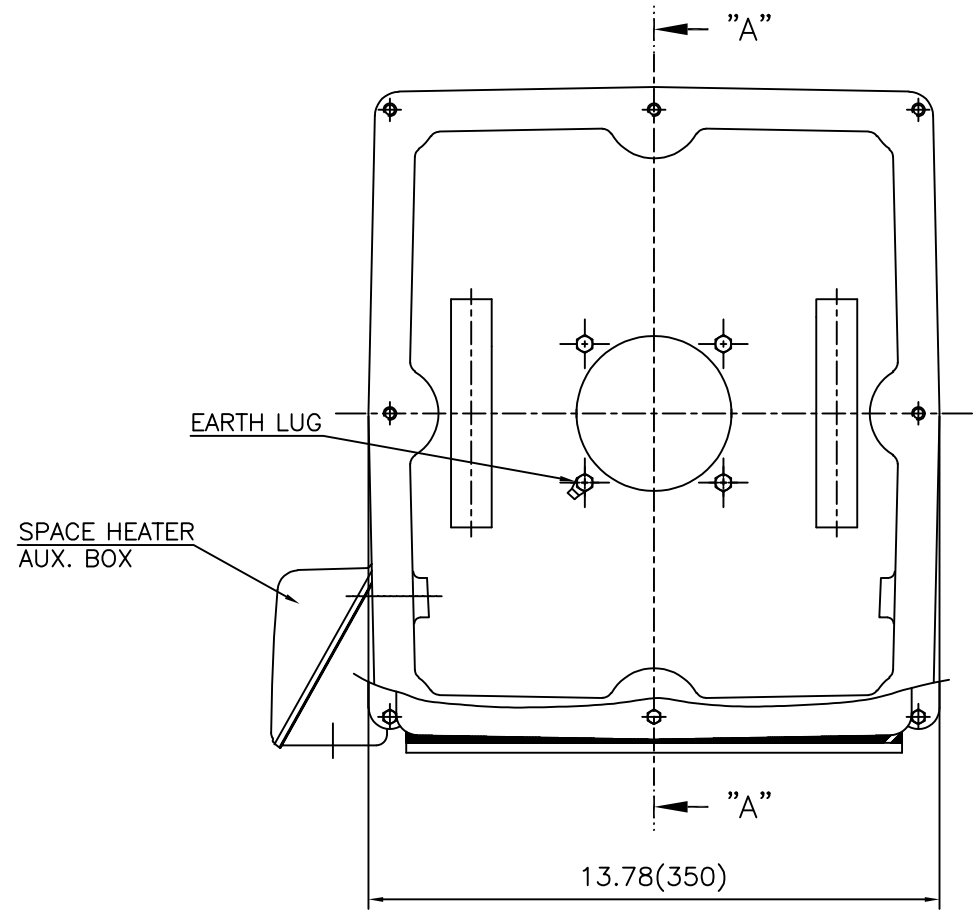

SEC. "A" - "A"

REV	DATE	CONTENTS	REVD BY	CHKD BY	CHKD BY	APPD BY

APPD BY	S.Y.KIM	UNIT	inch(mm)	SUBJECT	FR. L440 (CAST IRON)	DWG SIZE
CHKD BY		SCALE	1/3.5	TITLE	MAIN TERMINAL BOX ASS'Y	A3 (1:3.5)
CHKD BY	R.G.KIM	PROJEC'N	3rd Angle			
DSND BY	최승희	DATE	2023-10-19			
				REF. NO		Sheet No. of
				DWG NO	3M-248452	Revision No. 0

# Cls. I&II, Div. 2 IEEE 841

본 도면은 HD현대일렉트릭(주) 재산이며  
허가없이 복사할 수 없음 (취급주의)

THIS DRAWING IS PROPRIETARY TO HYUNDAI ELECTRIC. NO PART OF THIS DRAWING  
MAY BE REPRODUCED WITHOUT THE PERMISSION OF HYUNDAI ELECTRIC.

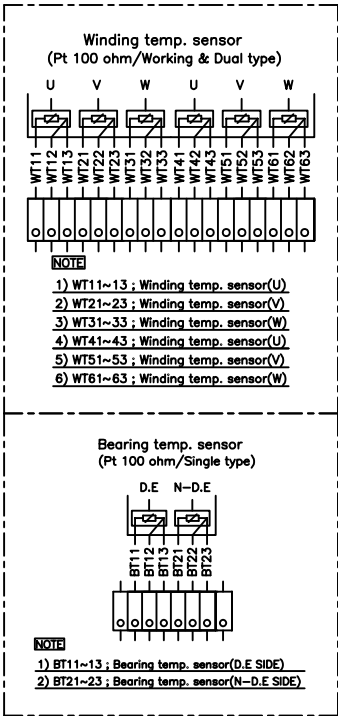
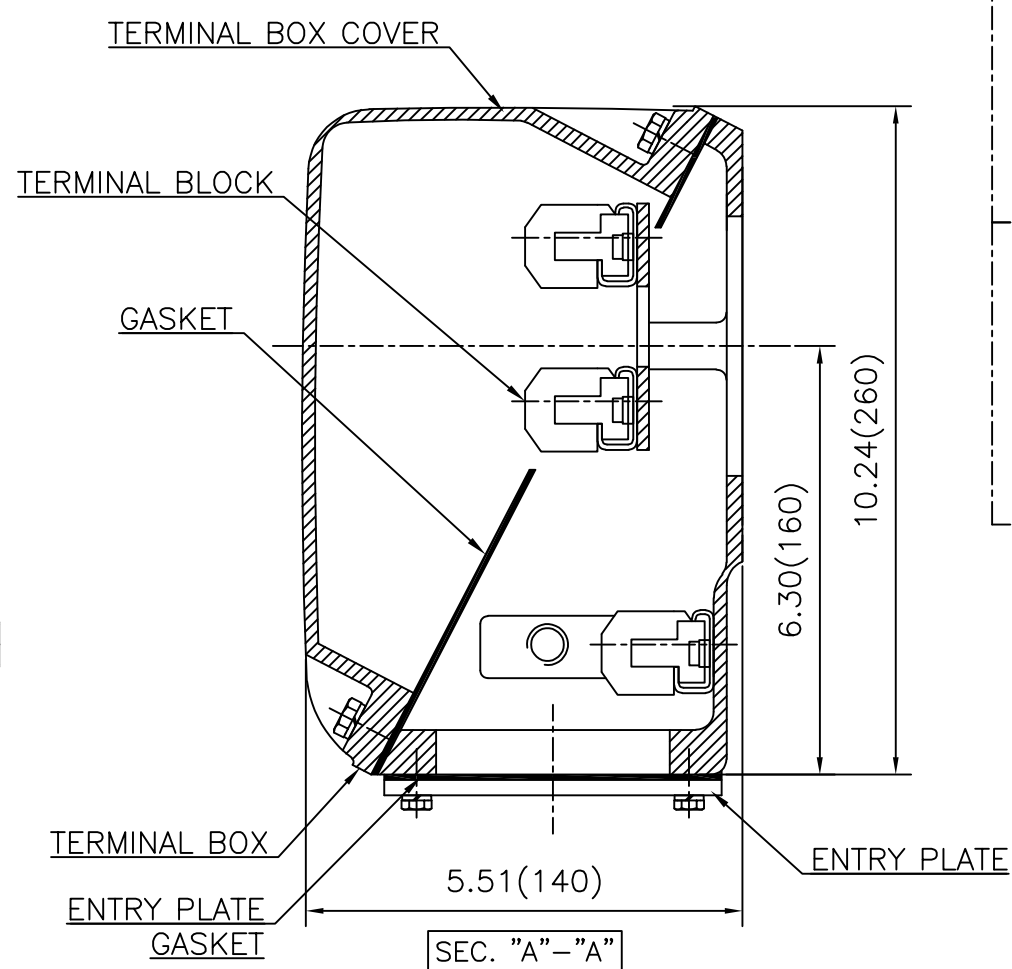
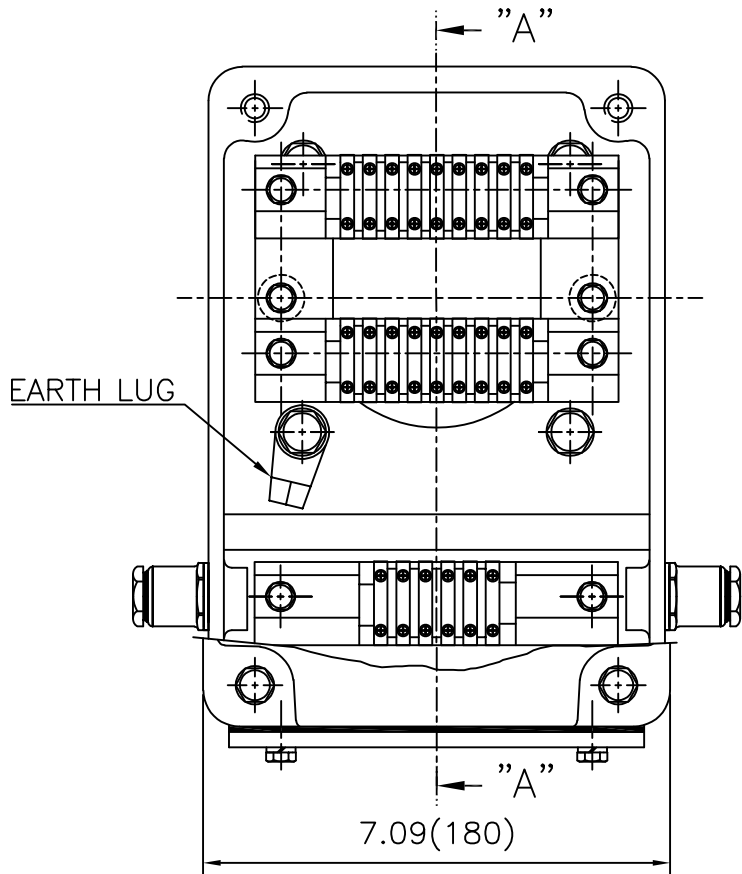

REV	DATE	CONTENTS	REVD BY	CHKD BY	CHKD BY	APPD BY

APPD BY	S.Y.KIM	UNIT	inch(mm)	SUBJECT	FR.360 (CAST IRON)	DWG SIZE	A3 (1:2.2)	
CHKD BY		SCALE	1/1	TITLE	AUX. TERMINAL BOX ASS'Y	REF. NO		
CHKD BY	R.G.KIM	PROJEC'N	3rd Angle	DWG NO		3M-165277	Sheet No.	of
DSND BY	배승희	DATE	2024-01-18			DWG NO	3M-165277	
							Revision No.	0



**Cls. I&II, Div. 2  
IEEE 841**

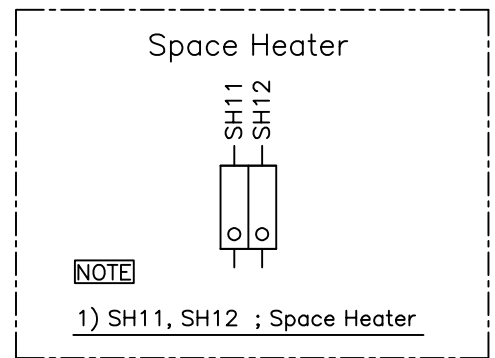
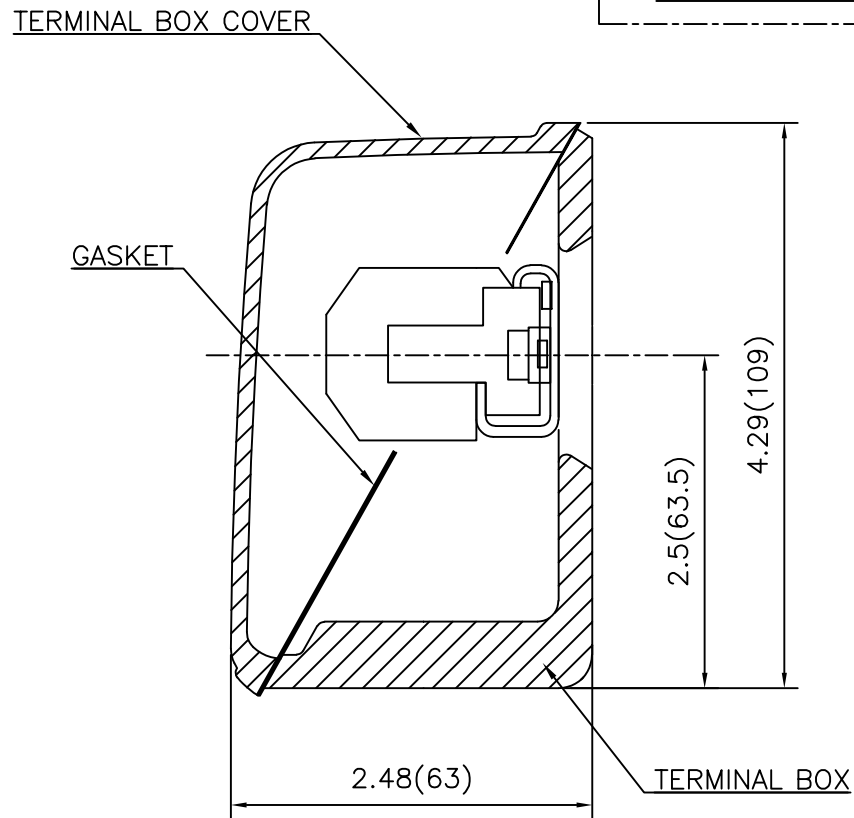
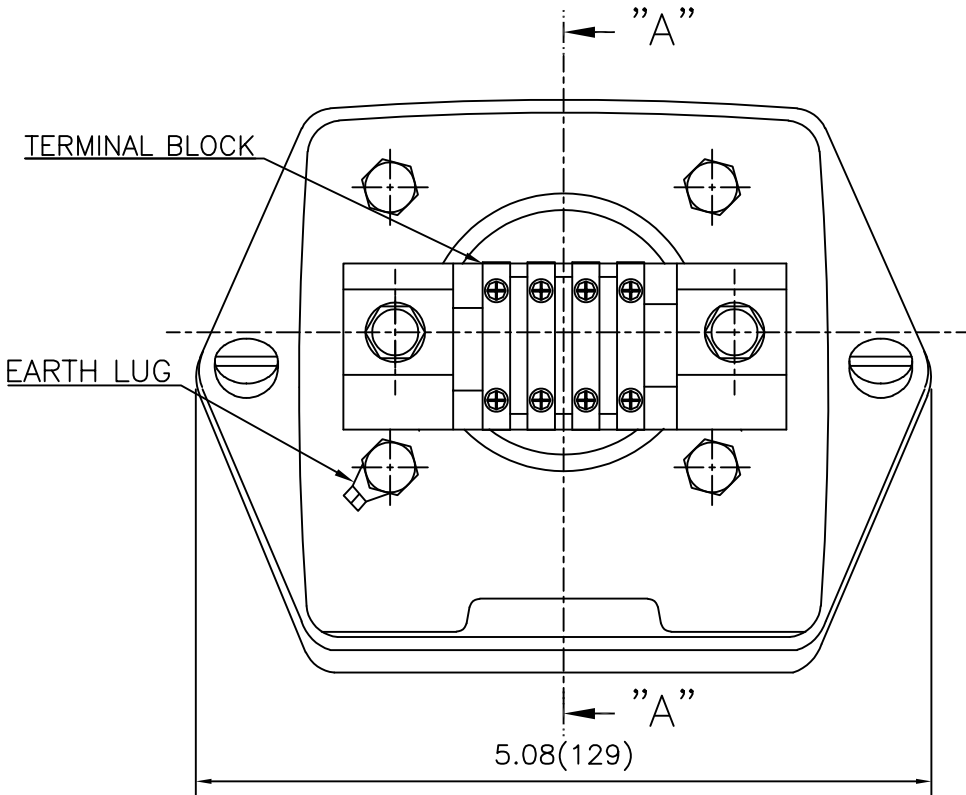

REV	DATE	CONTENTS	REVD BY	CHKD BY	CHKD BY	APPD BY

APPD BY	S.Y.KIM	UNIT	inch(mm)	SUBJECT	FR.180 (CAST IRON)	DWG SIZE
CHKD BY		SCALE	1/1	TITLE	SUB. TERMINAL BOX ASS'Y	A3 (1:1.1)
CHKD BY	R.G.KIM	PROJEC'N	3rd Angle			
DSND BY	배승희	DATE	2024-01-18			
				REF. NO		Sheet No. of
				DWG NO	3M-165278	Revision No. 0