

Customer :
Project Name :
Project No. :
Revision No. :

SPECIFICATION for INDUCTION MOTOR



0		For Bidding			
No.	DATE	DESCRIPTION	PREPARED BY	CHECKED BY	APPROVED BY



AC INDUCTION MOTOR DATA SHEET

IEEE841 TYPE

Catalog No.	IEEE500-18-5010-IBSH	Item No.	Rev. No. []
Project Name		Project No.	Quantity sets

GENERAL SPECIFICATION		PERFORMANCE DATA				
Frame Size	5010	Rated Output	375 kW 500 HP			
Type	PJP	Number of Poles	4			
Enclosure(Protection)	Totally Enclosed / IP55	Rotor Type	Squirrel Cage			
Method of Cooling	IC411(FC)	Starting Method*	D.O.L			
Rated Frequency	60 Hz	Rated Voltage	575 V	460 V	230 V	
Number of Phases	3	Current	Full Load	439.8 A	549.7 A 1,099.5 A	
Insulation Class	F		Locked-rotor**	720 %	720 % 720 %	
Temp. Rise at full load (by resistance method)		Efficiency				
at 1.0 S.F	80 deg. C	50% Load		93.2 %		
Motor Location	<input type="checkbox"/> Indoor <input type="checkbox"/> Outdoor	75% Load		95.2 %		
Altitude	Less than 1,000 meter	100% Load		96.2 %		
Relative Humidity	Less than 80 %	Power Factor(p.u)				
Ambient Temp.	40 deg. C (Max.)	50% Load		0.740		
Duty Type	Continuous (S1)	75% Load		0.840		
Service Factor	1.15	100% Load		0.890		
Mounting	B3	Speed at Full Load		1785 r.p.m		
Bearing	Type	Anti-Friction				
	DE/N-DE	NU324 / 6320C3-INS.				
	Lubricant	Grease(Polyrex-EM)				
External Thrust	Not applicable					
Coupling Method	<input type="checkbox"/> Direct <input type="checkbox"/> V-belt	Torque				
Shaft Extension	Single	Full Load		1,480.0 lb.ft		
Terminal Box	Main	Locked-rotor**		135 %		
	Aux.	Breakdown**		220 %		
Location	Refer to Outline Drawing	Moment of Inertia (J)				
Application		Load(Max.)		1,880.000 lb.ft2		
Area classification	Hazardous	Motor		176.332 lb.ft2		
Type of Ex-Protection	Class I&II, Division 2	Sound Pressure Level (No-load & mean value at 1m from motor)				
Applicable Standard	IEEE841, NEMA MG1, CSA C390			85 dB(A)		
ACCESSORIES *. Space Heater : 1EA/Motor		Vibration				3.8 mm/sec (peak)
		Permissible number of consecutive starts		Cold	2 times	
				Hot	1 time	
		Paint	Munsell No.	7.5BG6/1.5		
SPARE PARTS		SUBMITTAL DRAWING				
		Outline Dimension Drawing		Motor Weight(Approx.)		
		B3	LM-I0511B3PE001	4820 lb.		
REMARK 1. Premium efficiency according to NEMA MG1 2. Inverter Duty @ 1.0 Service Factor & F Temperature rise -. 10:1 VT (20:1 VT at 50% load) -. 10:1 CT -. CHp up to 1.5 times base speed, NEMA MG1 Part31 3. NDE side : Insulated bearing 4. CSA Certification -. Class I, Division 2, Group A, B, C & D; Temp code : T3 -. Class II, Division 2 Group F & G; Temp code : T3 5. Shaft material : AISI4140		Date	DSND	CHKD	CHKD	APPD
		2024-07-13	S.H. Lee	I.K. Kim	R.G. Kim	S.W. Kim

[Note] Others not mentioned in this data sheet shall be in accordance with maker standard.
 Above technical data are only design values and shall be guaranteed with tolerance of applicable standard.
 Inspection and performance test shall be done according to maker standard, if not mentioned.
 * In case of Inverter-Fed Motor, performance data is based on sine wave tests. It may be different from test data of Inverter combined motor.
 ** Data is based on rated voltage & frequency and is expressed as a percentage of full-load value.



1	2	3	4
REV	DATE	CONTENTS	REVD BY CHKD BY CHKD BY APPD BY

4.72



CROWN TRITON
Premium Efficiency AC 3 Phase Motor





500HP	4P	460V	Cat. No.	IEEE500-18-5010-IBSH			
Model	LATER		INS. Class	F	Amps	549.7	
Type	PJP	Duty	CONT	Code	H	Amb. 40°C	
Frame	5010	Encl.	TEFC	S.F.	1.15	RPM 1785	
Bearing	Drive	NU324	S.F.1.00 (10:1 C.T., 20:1 V.T., NEMA-MG1 Part31)			3/4 Eff.	95.2%
	Opp.	6320C3-INS.				NEMA Design	B Torque
Usable at							
CSA Certified for	CLASS I, Div. 2, Gr. A, B, C & D		CLASS II, Div. 2, Gr. F & G		Temp. Code (sine wave)	Frame	L440FR - 500FR
	CLASS I, Zone 2, Gr. IIA, IIB, & IIC					Amb. 40°C	T3 (200°C)
						Amb. 55°C	T3 (200°C)
No.	-	Date	-	Weight	4820 lb		

IEEE Std 841-2021
4M-136054

MARINE DUTY IEEE45
Made in Korea H1



2.36

APPD BY	S.Y.KIM	UNIT	INCH	SUBJECT	CSA Class I, Division2 IEEE841 (XL)	DWG SIZE
CHKD BY	I.K.KIM	SCALE	NONE			A4 (1:1)
CHKD BY	R.G.KIM	PROJEC'N	3rd Angle	TITLE NAMEPLATE DRAWING		
DSND BY	S.H.LEE	DATE	2024.06.07			
				REF. NO	4M-136054	Sheet No. of
				DWG NO	NP-IEEE500-18-5010-IBSH	Revision No. 0

Type :	PJP
Full Load Torque :	1480.0 lb.ft
Load moment of Inertia (J) :	1880.000 lb.ft2
Motor moment of Inertia (J) :	176.332 lb.ft2

375kW	500HP	4 P	60 Hz
Speed at Full Load :			1785 RPM
Rated Voltage	575V	460V	230V
Full Load Current	439.8A	549.7A	#####

SPEED VS TORQUE & CURRENT CURVE

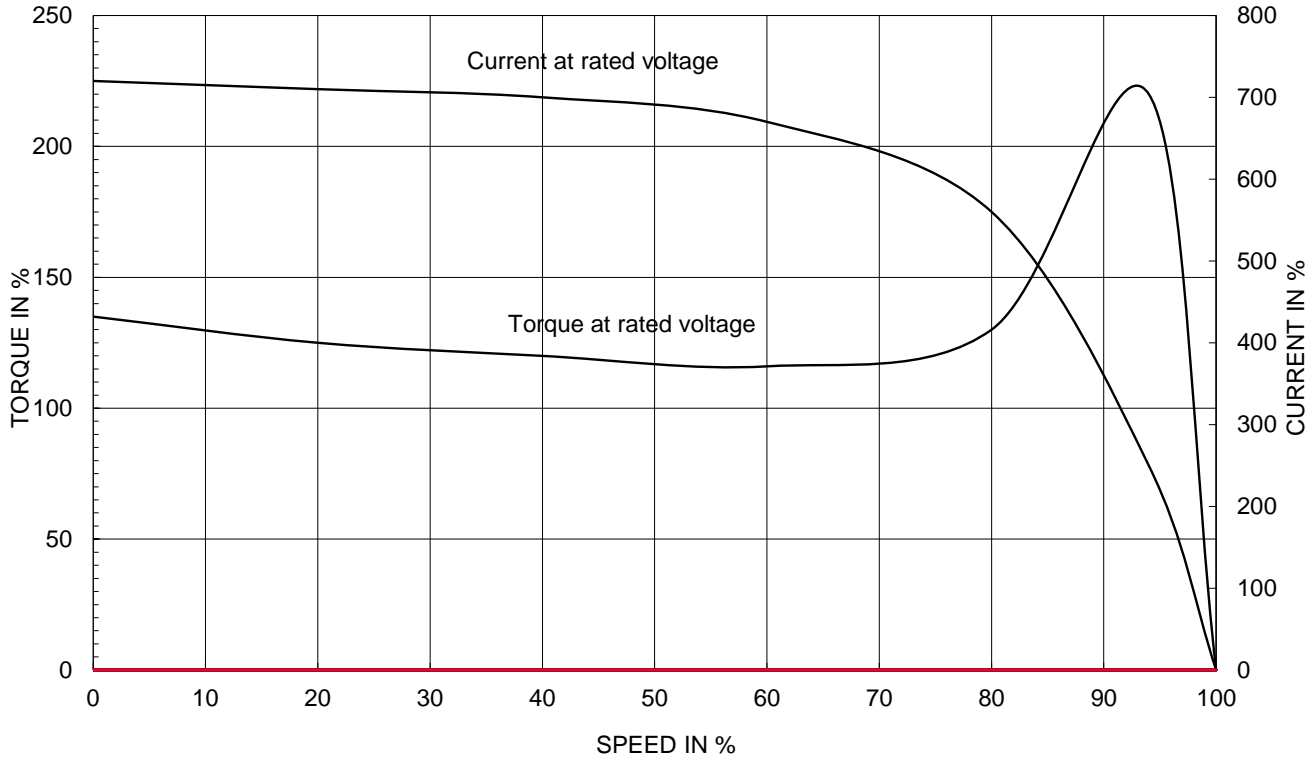

OUTPUT VS EFF., P.F & CURRENT CURVE

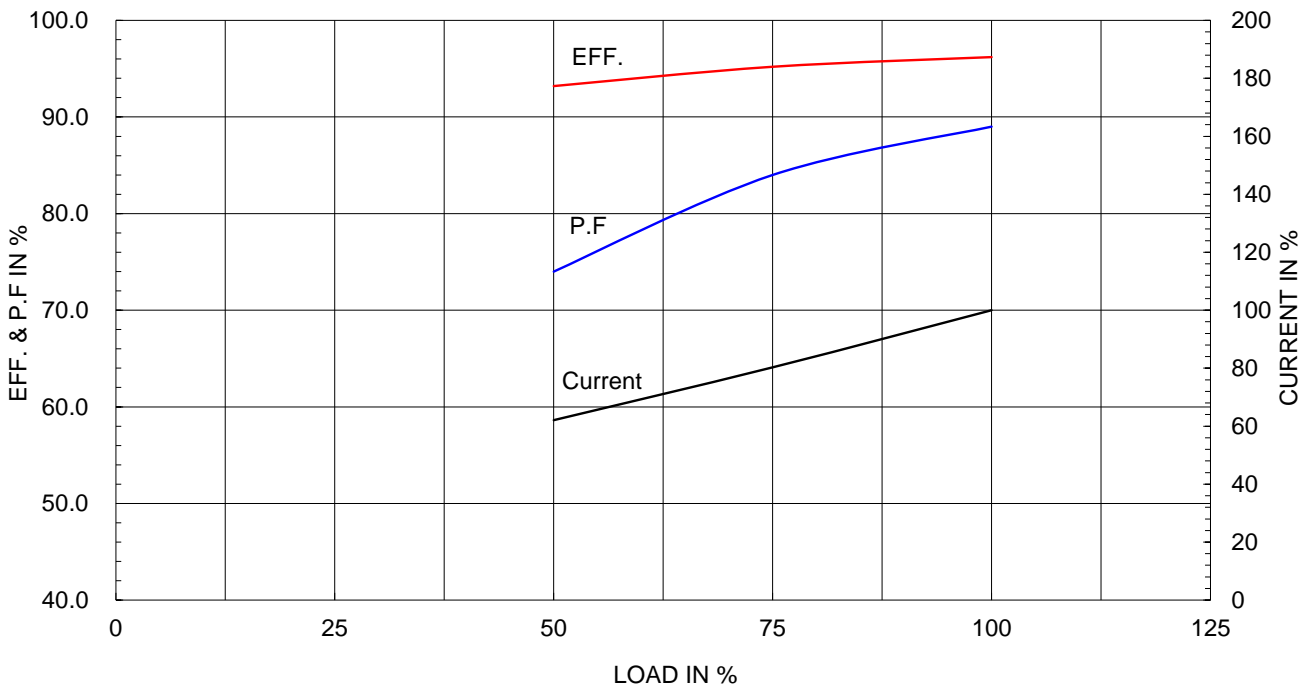

▽	50S	REV	DATE	CONTENTS	REVD BY	CHKD BY	CHKD BY	APPD BY
▽▽	12.5S							
▽▽▽	3.2S							
▽▽▽▽	0.4S							

IEEE841

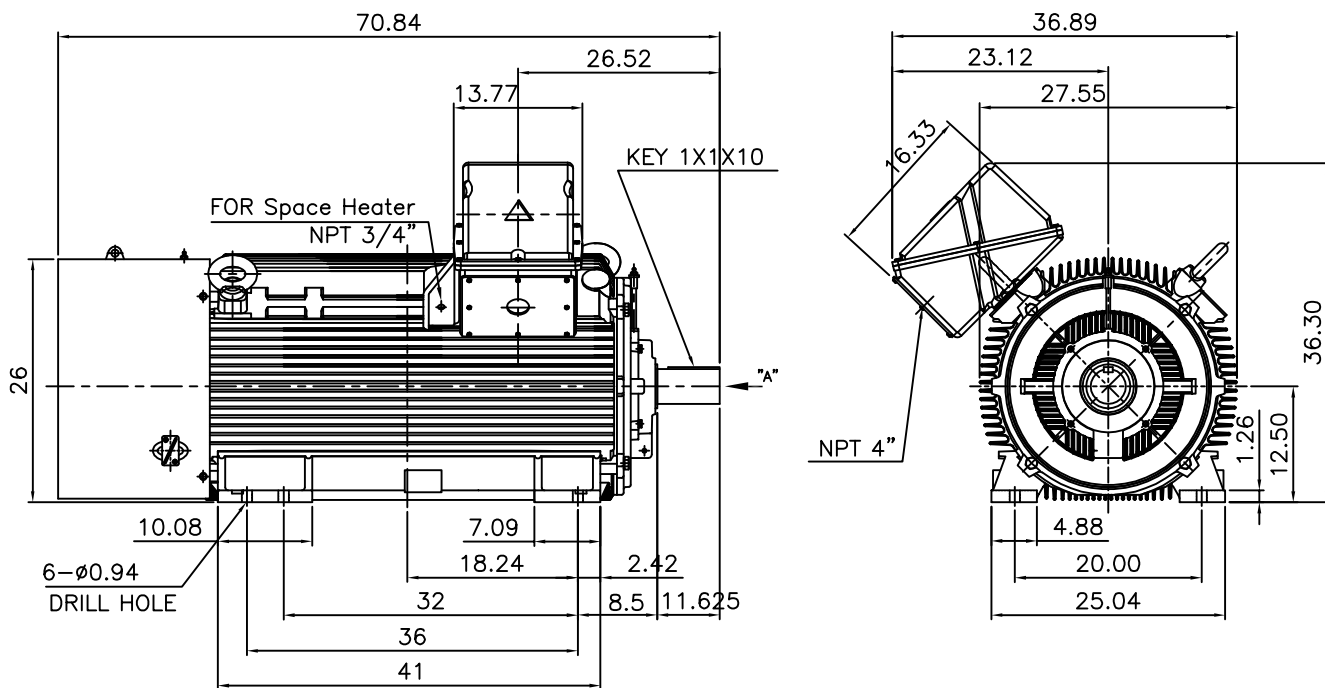

NOTE

1.TOLERANCE :

CENTER HEIGHT	12.5	+0.000	-0.060
SHAFT DIAMETER	ø3.875	+0.000	-0.001
KEYWAY WIDTH	1	+0.003	-0.000

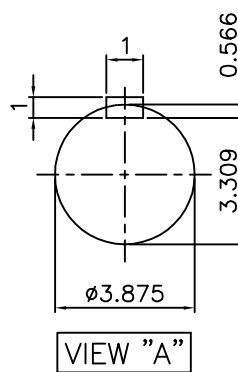

APPD BY	S.Y.KIM	UNIT	INCH	SUBJECT	Fr.5010/5011T	DWG SIZE	A4 (1:20)
CHKD BY	O.J.KIM	SCALE	1/20	TITLE	CAST IRON T-BOX		
CHKD BY	R.G.KIM	PROJEC'N	3각법 (3rd Angle)	OUTLINE			
DSND BY	H.K.LEE	DATE	2021-04-27				
				REF. NO		Sheet No.	of
				DWG NO	LM-I0511B3PE001	Revision No.	0

**Cls. I&II, Div. 2
IEEE 841**

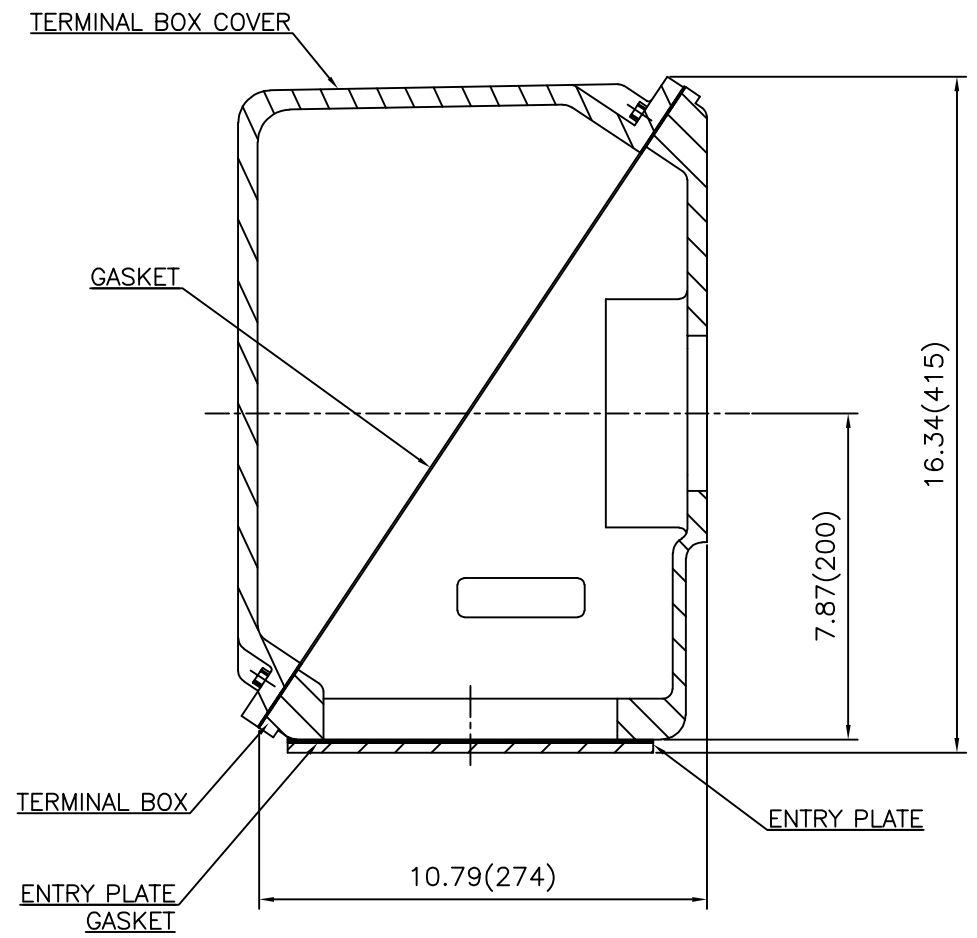
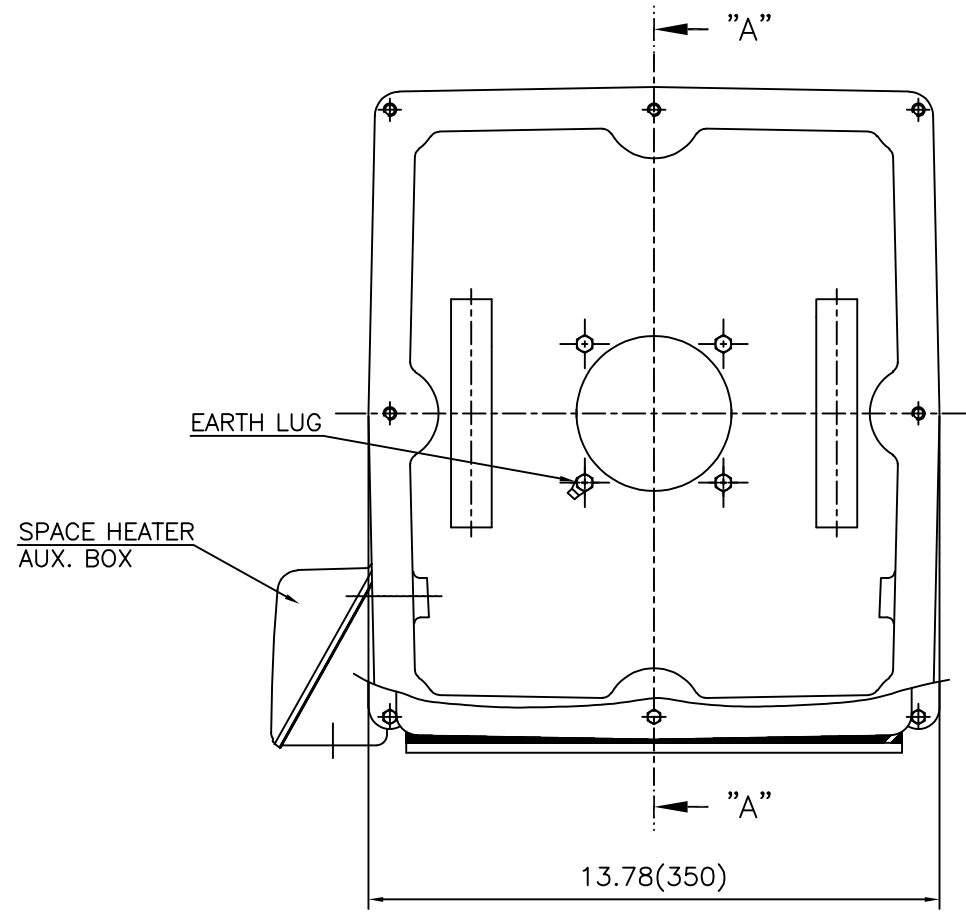

SEC. "A" - "A"

REV	DATE	CONTENTS	REVD BY	CHKD BY	CHKD BY	APPD BY
1						
2						
3						
4						

APPD BY	S.Y.KIM	UNIT	inch(mm)	SUBJECT	FR. L440 (CAST IRON)	DWG SIZE
CHKD BY		SCALE	1/3.5	TITLE	MAIN TERMINAL BOX ASS'Y	A3 (1:3.5)
CHKD BY	R.G.KIM	PROJEC'N	3rd Angle			
DSND BY	최승희	DATE	2023-10-19			
				REF. NO		Sheet No. of
				DWG NO	3M-248452	Revision No. 0

**Cls. I&II, Div. 2
IEEE 841**

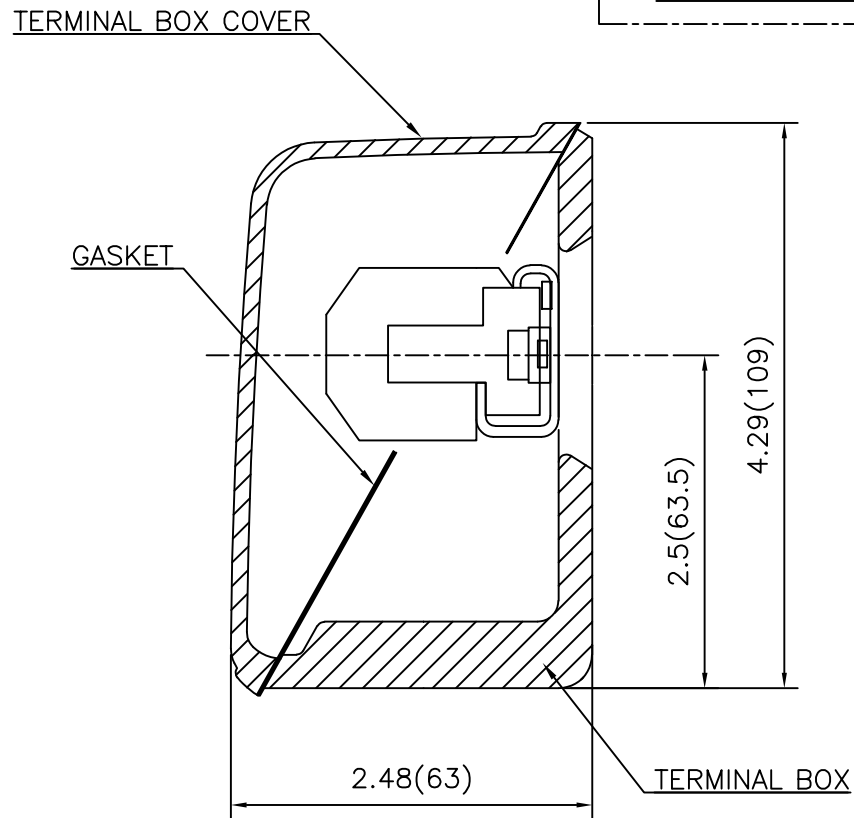
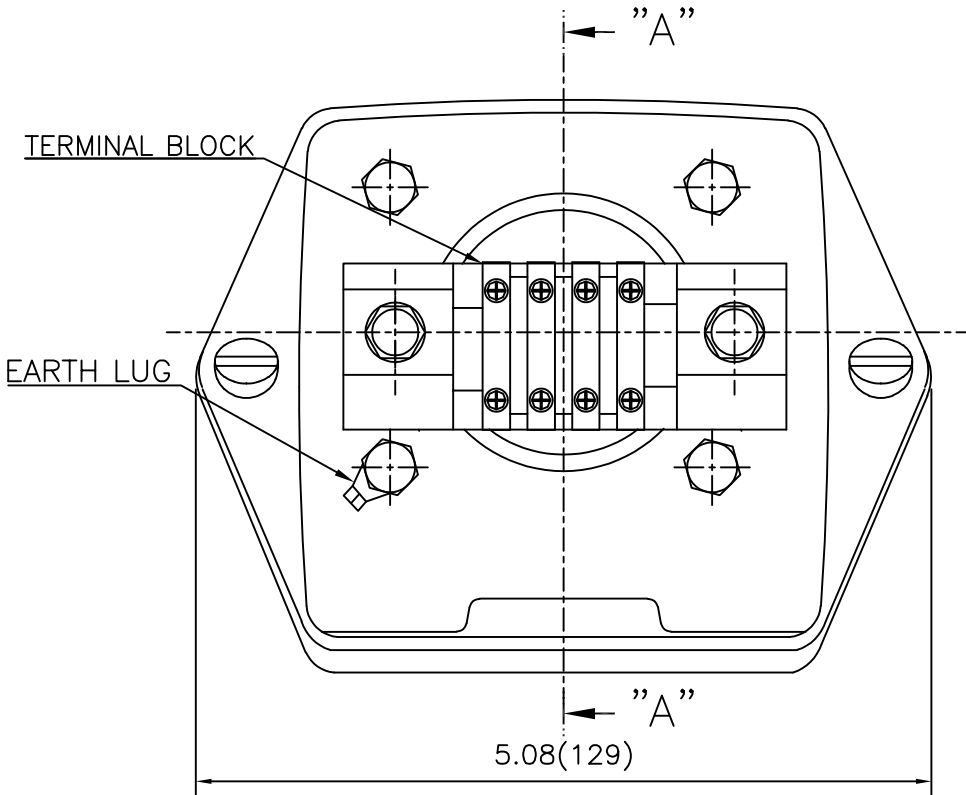

SEC. "A" - "A"

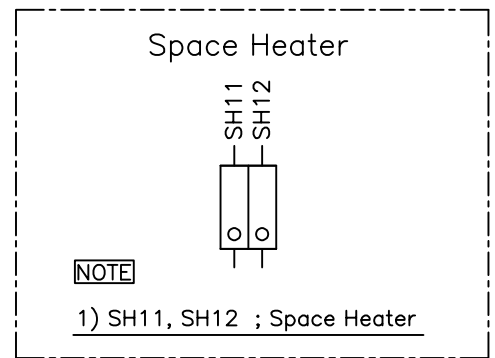

REV	DATE	CONTENTS	REVD BY	CHKD BY	CHKD BY	APPD BY

APPD BY	S.Y.KIM	UNIT	inch(mm)	SUBJECT	FR.180 (CAST IRON)	DWG SIZE
CHKD BY		SCALE	1/1	TITLE	SUB. TERMINAL BOX ASS'Y	A3 (1:1.1)
CHKD BY	R.G.KIM	PROJEC'N	3rd Angle			
DSND BY	배승희	DATE	2024-01-18			
				REF. NO		Sheet No. of
				DWG NO	3M-165278	Revision No. 0