

Customer :
Project Name :
Project No. :
Revision No. :

SPECIFICATION for INDUCTION MOTOR



0		For Bidding			
No.	DATE	DESCRIPTION	PREPARED BY	CHECKED BY	APPROVED BY



AC INDUCTION MOTOR DATA SHEET

IEEE841 TYPE

Catalog No.	IEEE50-36-326TS	Item No.	Rev. No.	[]
Project Name		Project No.	Quantity	sets

GENERAL SPECIFICATION			PERFORMANCE DATA			
Frame Size	326TS		Rated Output	37 kW 50 HP		
Type	PJP		Number of Poles	2		
Enclosure(Protection)	Totally Enclosed / IP55		Rotor Type	Squirrel Cage		
Method of Cooling	IC411(FC)		Starting Method*	D.O.L		
Rated Frequency	60 Hz		Rated Voltage	575 V	460 V	230 V
Number of Phases	3		Current	Full Load	43.7 A	54.6 A 109.1 A
Insulation Class	F			Locked-rotor**	850 %	850 % 850 %
Temp. Rise at full load (by resistance method)			Efficiency			
at 1.0 S.F	80 deg. C		50% Load 90.0 %			
Motor Location	<input type="checkbox"/> Indoor <input type="checkbox"/> Outdoor		75% Load 92.0 %			
Altitude	Less than 1,000 meter		100% Load 93.0 %			
Relative Humidity	Less than 80 %		Power Factor(p.u)			
Ambient Temp.	40 deg. C (Max.)		50% Load 0.765			
Duty Type	Continuous (S1)		75% Load 0.865			
Service Factor	1.15		100% Load 0.915			
Mounting	B3		Speed at Full Load	3560 r.p.m		
Bearing	Type	Anti-Friction	Torque			
	DE/N-DE	6212ZC3 / 6212ZC3	Full Load 73.2 lb.ft			
	Lubricant	Grease(Polyrex-EM)	Locked-rotor** 150 %			
External Thrust	Not applicable		Breakdown** 230 %			
Coupling Method	<input checked="" type="checkbox"/> Direct <input type="checkbox"/> V-belt		Moment of Inertia (J)			
Shaft Extension	Single		Load(Max.) 49.240 lb.ft2			
Terminal Box	Main	Cast Iron	Motor 4.272 lb.ft2			
	Aux.	No	Sound Pressure Level (No-load & mean value at 1m from motor)			
Location	Refer to Outline Drawing		82 dB(A)			
Application			Vibration 3.8 mm/sec (peak)			
Area classification	Hazardous		Permissible number of consecutive starts			
Type of Ex-Protection	Class I&II, Division 2		Cold 3 times			
Applicable Standard	IEEE841, NEMA MG1, CSA C390		Hot 2 times			
			Paint	Munsell No.	7.5BG6/1.5	

ACCESSORIES

SUBMITTAL DRAWING
Outline Dimension Drawing \ Motor Weight(Approx.)
B3 LM-I1326B3CL001 540 lb.

REMARK

1. Premium efficiency according to NEMA MG1
2. Inverter Duty @ 1.0 Service Factor & F Temperature rise
 - 10:1 VT (20:1 VT at 50% load)
 - 10:1 CT
 - CHP up to 1.5 times base speed, NEMA MG1 Part31
3. CSA Certification
 - Class I, Division 2, Group A, B, C & D
 - Class II, Division 2 Group E, F & G (Group E : up to 320Fr.)
4. Service Factor 1.15 and Temperature rise B are applicable under the condition of sine wave power.
5. Service Factor 1.25 is applicable to motors of 100HP or less with temperature rise F & Non-Hazardous.

Date	DSND	CHKD	CHKD	APPD
2024-07-13	S.H. Lee	I.K. Kim	R.G. Kim	S.W. Kim

[Note] Others not mentioned in this data sheet shall be in accordance with maker standard.
 Above technical data are only design values and shall be guaranteed with tolerance of applicable standard.
 Inspection and performance test shall be done according to maker standard, if not mentioned.
 * In case of Inverter-Fed Motor, performance data is based on sine wave tests. It may be different from test data of Inverter combined motor.
 ** Data is based on rated voltage & frequency and is expressed as a percentage of full-load value.

1	2	3	4
REV	DATE	CONTENTS	REVD BY

4.72

CROWN TRITON
Premium Efficiency AC 3 Phase Motor



50HP	2P	460V	Cat. No.	IEEE50-36-326TS				
Model	HLS326SR13		INS. Class	F	HD-F1	Amps	54.6	
Type	HLS	Duty	CONT	Code	J	Amb.	40°C	
Frame	326TS	Encl.	TEFC	S.F.	1.15	RPM	3560	
Bearing	Drive	6212ZC3		S.F.1.00 (10:1 C.T., 20:1 V.T., NEMA-MG1 Part31)		3/4 Eff.	92%	
	Opp.	6212ZC3				NEMA Design	B Torque	
Usable at	50Hz 40HP 380V 59.1A 2960rpm S.F.: 1.0 Eff.: 92% Code: J							
	50Hz 40HP 400/415V 56.4/54.7A 2965/2965rpm S.F.: 1.0 Eff.: 92/92% Code: K/L							
CSA Certified for	Model	LATER		Type	PJP			
	CLASS I, Div. 2, Gr. A, B, C & D CLASS I, Zone 2, Gr. IIA, IIB, & IIC	CLASS II, Div. 2, Gr. E, F & G (Gr. E : Up to 320FR)		Temp. Code (sine wave)	Frame	140~320FR	360~400FR	440FR
		Amb. 40°C	T3C (160°C)		T3B (165°C)	T3A (180°C)		
Amb. 55°C	T3A (180°C)	T3A (180°C)	T3 (200°C)					
No.	-		Date	-		Weight	540 lb	

IEEE Std 841-2021
4M-135701

MARINE DUTY IEEE45
Made in Korea H1



2.36

APPD BY	S.Y.KIM	UNIT	INCH	SUBJECT	CSA Class I, Division2 IEEE841 (HL)	DWG SIZE	A4 (1:1)
CHKD BY	I.K.KIM	SCALE	NONE				
CHKD BY	R.G.KIM	PROJEC'N	3rd Angle	TITLE NAMEPLATE DRAWING			
DSND BY	S.H.LEE	DATE	2024.06.07				
				REF. NO	4M-135701	Sheet No. of	
				DWG NO	NP-IEEE50-36-326TS	Revision No. 0	

Type :	PJP
Full Load Torque :	73.2 lb.ft
Load moment of Inertia (J) :	49.240 lb.ft2
Motor moment of Inertia (J) :	4.272 lb.ft2

37kW	50HP	2 P	60 Hz
Speed at Full Load :			3560 RPM
Rated Voltage	575V	460V	230V
Full Load Current	43.7A	54.6A	109.1A

SPEED VS TORQUE & CURRENT CURVE

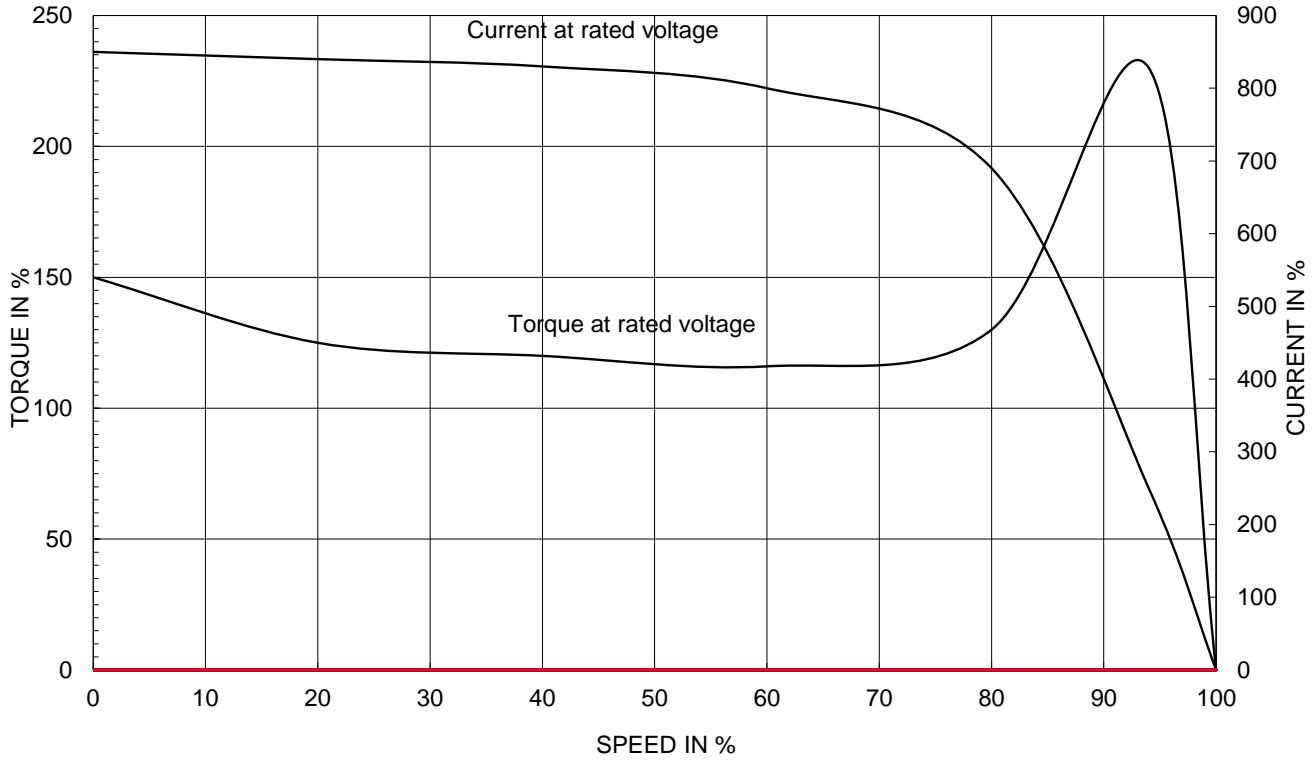

OUTPUT VS EFF., P.F & CURRENT CURVE

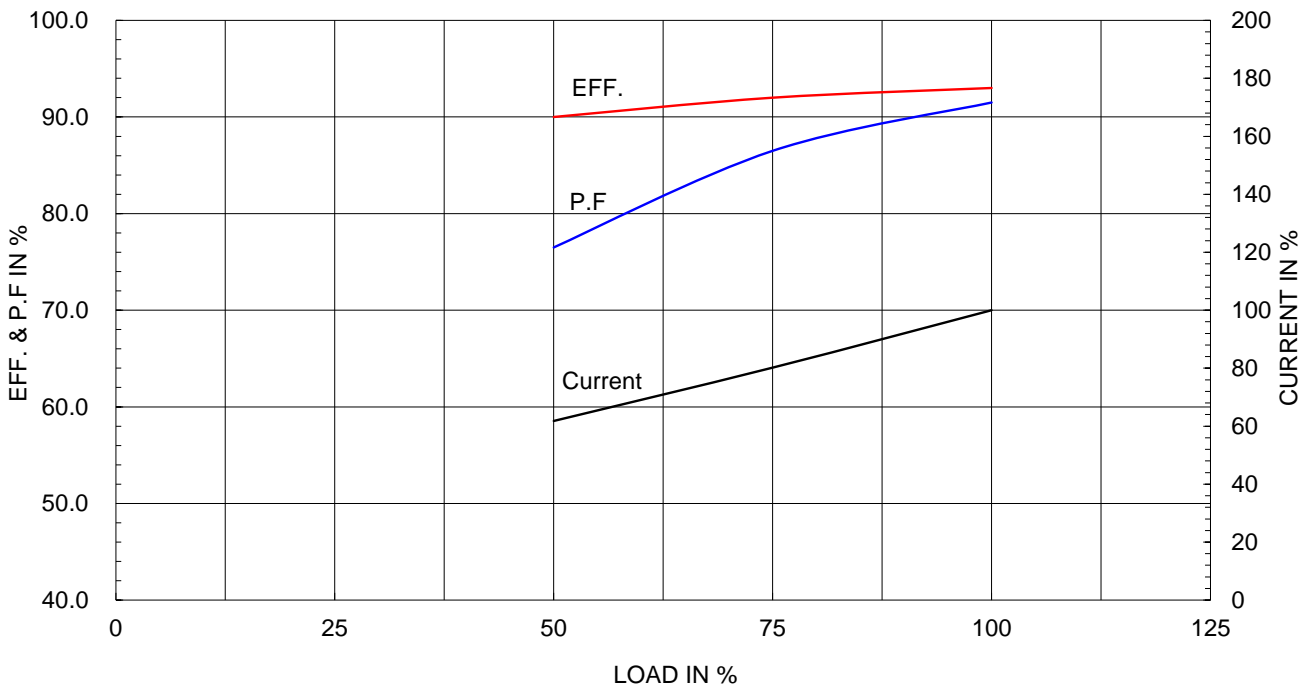

본 도면은 HD현대일렉트릭(주) 재산이며 허가없이 복사할 수 없음 (취급유의)

THIS DRAWING IS PROPRIETARY TO HYUNDAI ELECTRIC. NO PART OF THIS DRAWING MAYBE REPRODUCED WITHOUT THE PERMISSION OF HYUNDAI ELECTRIC.

▽	50S	REV	DATE	CONTENTS	REVD BY	CHKD BY	CHKD BY	APPD BY
▽▽	12.5S							
▽▽▽	3.2S							
▽▽▽▽	0.4S							

IEEE841

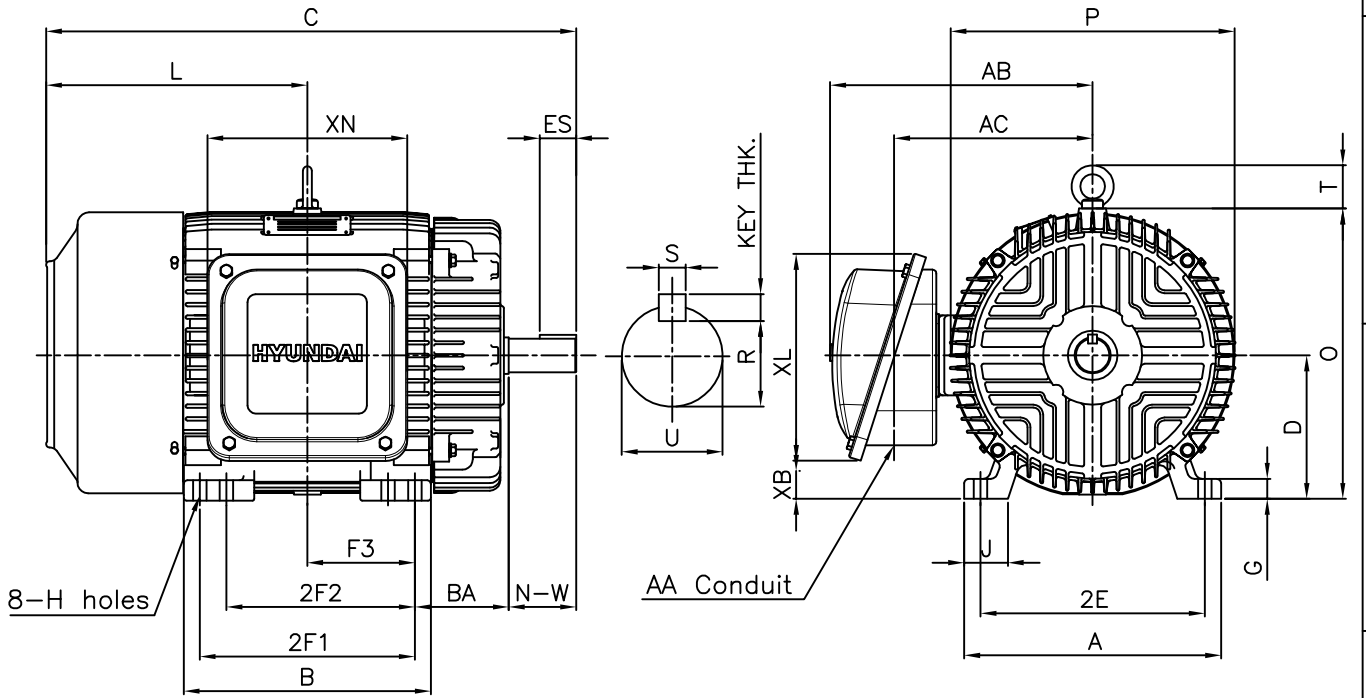

DIMENSIONS

Unit : inch

MOUNTING										CONDUIT BOX					APPROX. WGT.(LB)	
A	B	2E	2F1 ⁵⁾	2F2 ⁴⁾	F3	G	J	H	AA	AB	AC	XB	XL	XN	324T	326T
14.33	13.78	12.50	12.00	10.50	6.00	1.11	2.36	0.66	2.00	16.31	11.41	2.13	11.38	11.14	550	560

OVERALL									SHAFT			KEY THK.	BEARING	
BA	C	D	L	O	P	T	U	N-W	KEYWAY		DRIVE END		OPP. DRIVE END	
									R	ES	S			
5.25	29.96	8.00	14.96	16.19	15.84	2.41	1.875	3.75	1.591	2.03	0.500	0.500	6313ZC3	6211ZC3

NOTE

- 1.Dimension "D" tolerance : +0.00inch - 0.03inch
- 2.Dimension "U" tolerance : +0.000inch - 0.001inch
- 3.Dimension "R" tolerance : +0.000inch - 0.015inch
- 4.Location of holes for 324TS frame

APPD BY	S.Y.KIM	UNIT	INCH	SUBJECT	NEMA 324TS/326TS	DWG SIZE	A4 (1:1)	
CHKD BY	R.G.KIM	SCALE	NONE	TITLE	OUTLINE	REF. NO	350A8111BA	
CHKD BY	Y.H.BAE	PROJEC'N	3각법(3rd Angle)	DWG NO		LM-I1326B3CL001	Sheet No.	of
DSND BY	H.K.LEE	DATE	2021-04-30				Revision No.	0





Cls. I&II, Div. 2
IEEE 841

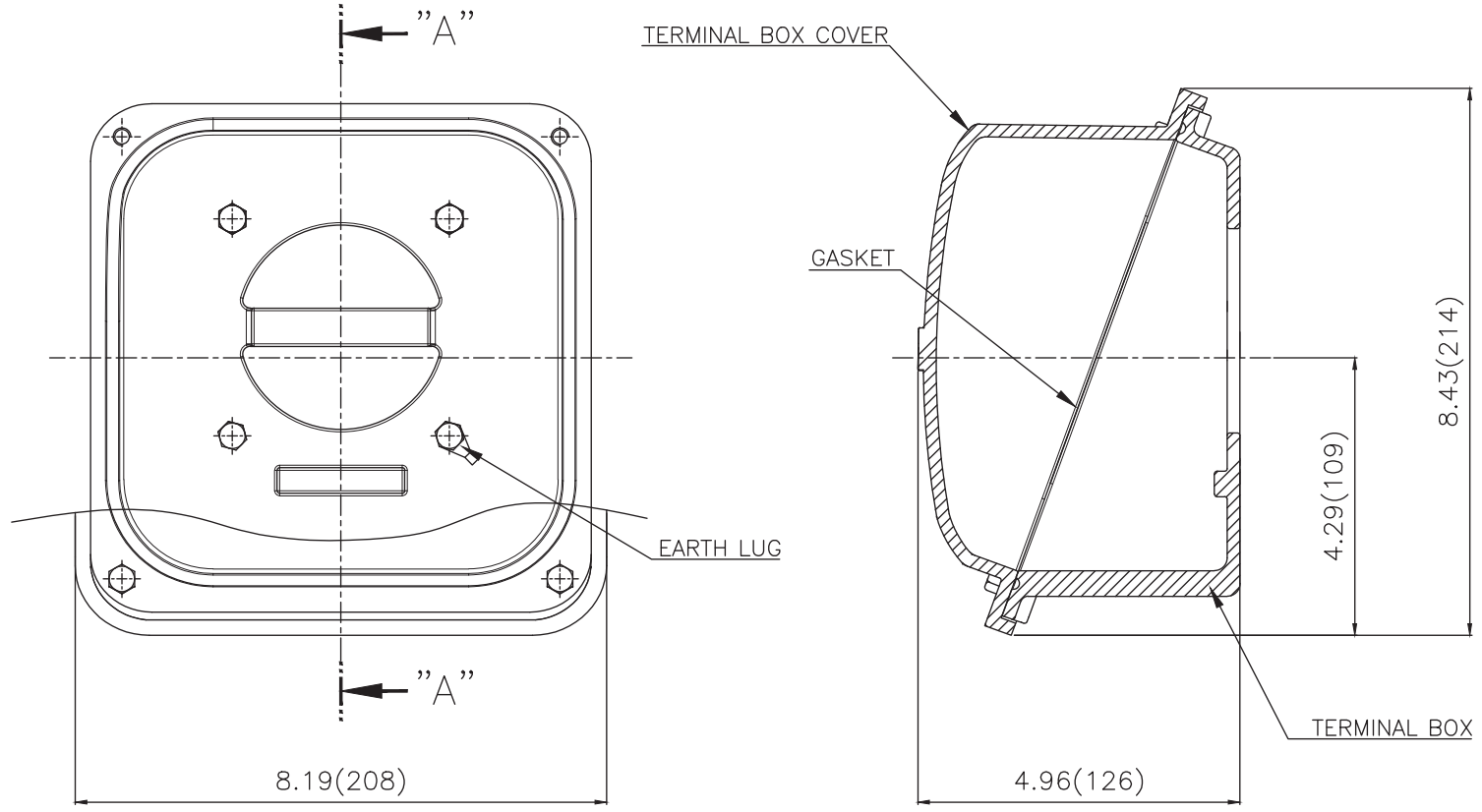

▽	50S
▽▽	12.5S
▽▽▽	3.2S
▽▽▽▽	0.4S

REV	DATE	CONTENTS	REVD BY	CHKD BY	CHKD BY	APPD BY

일반가공공차		일반제관공차	
1-4	±0.1	6-30	±0.5
4-18	±0.2	30-120	±0.8
18-63	±0.3	120-315	±1.2
63-250	±0.5	315-1000	±2.0
250-	±0.8	1000-	±3.0

Q'TY	DESCRIPTION	MATERIAL	DIMENSION	WEIGHT	PART NO.	REMARK	NO.
APPD BY	S.Y.KIM	UNIT	inch(mm)	SUBJECT	FR. 250-280 (CAST IRON)	DWG SIZE	
CHKD BY		SCALE	1/2	TITLE	TERMINAL BOX ASS'Y		
CHKD BY	R.G.KIM	PROJEC'N	3rd Angle	DATE	2023-10-19		
DSND BY	배승희						
REF. NO		Sheet No.	of				
DWG NO	3M-248458	Revision No.	0				

