

Customer :
Project Name :
Project No. :
Revision No. :

SPECIFICATION for INDUCTION MOTOR



0		For Bidding			
No.	DATE	DESCRIPTION	PREPARED BY	CHECKED BY	APPROVED BY



AC INDUCTION MOTOR DATA SHEET

IEEE841 TYPE

Catalog No.	IEEE5-12-215T	Item No.	Rev. No.	[]
Project Name		Project No.	Quantity	sets

GENERAL SPECIFICATION			PERFORMANCE DATA			
Frame Size	215T		Rated Output	3.7 kW 5 HP		
Type	PJP		Number of Poles	6		
Enclosure(Protection)	Totally Enclosed	/ IP55	Rotor Type	Squirrel Cage		
Method of Cooling	IC411(FC)		Starting Method*	D.O.L		
Rated Frequency	60 Hz		Rated Voltage	575 V	460 V	230 V
Number of Phases	3		Current	Full Load	6.10 A	7.63 A 15.26 A
Insulation Class	F			Locked-rotor**	680 %	680 % 680 %
Temp. Rise at full load (by resistance method)			Efficiency			
at 1.0 S.F	80 deg. C		50% Load		86.5 %	
Motor Location	<input type="checkbox"/> Indoor <input type="checkbox"/> Outdoor		75% Load		88.5 %	
Altitude	Less than 1,000 meter		100% Load		89.5 %	
Relative Humidity	Less than 80 %		Power Factor(p.u)			
Ambient Temp.	40 deg. C (Max.)		50% Load		0.530	
Duty Type	Continuous (S1)		75% Load		0.630	
Service Factor	1.15		100% Load		0.680	
Mounting	B3		Speed at Full Load	1180 r.p.m		
Bearing	Type	Anti-Friction	Torque			
	DE/N-DE	6208ZC3 / 6208ZC3	Full Load		22.1 lb.ft	
	Lubricant	Grease(Polyrex-EM)	Locked-rotor**		170 %	
External Thrust	Not applicable		Breakdown**		220 %	
Coupling Method	<input checked="" type="checkbox"/> Direct <input type="checkbox"/> V-belt		Moment of Inertia (J)			
Shaft Extension	Single		Load(Max.)		96.700 lb.ft2	
Terminal Box	Main	Cast Iron	Motor		1.234 lb.ft2	
	Aux.	No	Sound Pressure Level (No-load & mean value at 1m from motor)			
	Location	Refer to Outline Drawing			57 dB(A)	
Application			Vibration		3.8 mm/sec (peak)	
Area classification	Hazardous		Permissible number of consecutive starts		Cold 3 times Hot 2 times	
Type of Ex-Protection	Class I&II, Division 2		Paint	Munsell No.	7.5BG6/1.5	
Applicable Standard	IEEE841, NEMA MG1, CSA C390					

ACCESSORIES

SUBMITTAL DRAWING		
Outline Dimension Drawing	Motor Weight(Approx.)	
B3	LM-I2215B3PLV23	175 lb.

SPARE PARTS

REMARK				
1. Premium efficiency according to NEMA MG1 2. Inverter Duty @ 1.0 Service Factor & F Temperature rise -. 10:1 VT (20:1 VT at 50% load) -. 10:1 CT -. CHP up to 1.5 times base speed, NEMA MG1 Part31 3. CSA Certification -. Class I, Division 2, Group A, B, C & D -. Class II, Division 2 Group E, F & G (Group E : up to 320Fr.) 4. Service Factor 1.15 and Temperature rise B are applicable under the condition of sine wave power. 5. Service Factor 1.25 is applicable to motors of 100HP or less with temperature rise F & Non-Hazardous.				
Date	DSND	CHKD	CHKD	APPD
2024-07-13	S.H. Lee	I.K. Kim	R.G. Kim	S.W. Kim

[Note] Others not mentioned in this data sheet shall be in accordance with maker standard.
 Above technical data are only design values and shall be guaranteed with tolerance of applicable standard.
 Inspection and performance test shall be done according to maker standard, if not mentioned.
 * In case of Inverter-Fed Motor, performance data is based on sine wave tests. It may be different from test data of Inverter combined motor.
 ** Data is based on rated voltage & frequency and is expressed as a percentage of full-load value.

1	2	3	4
REV	DATE	CONTENTS	REVD BY

3.94

CROWN TRITON G2 Premium Efficiency AC 3 Phase Motor Cat. No. IEEE5-12-215T

5HP	6P	460V	Amps	7.63	Type	HLS	Amb.	40°C	
Frame	215T	Duty	CONT	Encl.	TEFC	Model	HLS215SR338	NEMA Nom. Eff. 89.5%	
RPM	1180	Hertz	60Hz	S.F.	1.15	INS. Class	F HD-F1	3/4 Eff. 88.5%	
Bearing	Drive	6208ZC3	S.F.1.25 (When 100HP or less, Temp Rise F & Non-Hazardous)				NEMA Design	B Torque	
	Opp.	6208ZC3	S.F.1.00 (10:1 C.T., 20:1 V.T., NEMA-MG1 Part31)				Code	K	
Usable at	50Hz 3HP 380V 8.1A 980rpm S.F.: 1.0 Eff.: 81.8% Code: L								
	50Hz 3HP 400/415V 9.1/10.2A 980/985rpm S.F.: 1.0 Eff.: 81.8/81.8% Code: L/L								
CSA Certified for	Model	LATER			Type	PJP	Temp. Code	Frame	140-320FR
	CLASS I, Div. 2, Gr. A, B, C & D		CLASS II, Div. 2, Gr. E, F & G (Gr. E : up to 320FR)			(Sine Wave)	Amb.40°C	T3C (160°C)	
	CLASS I, Zone 2, Gr. IIA, IIB & IIC						Amb.55°C	T3A (180°C)	
No.	-		Date	-		Weight	175 lb		

1.57

APPD BY	S.Y.KIM	UNIT	INCH	SUBJECT	CSA Class I, Division2 IEEE841 (HL)	DWG SIZE
CHKD BY	I.K.KIM	SCALE	NONE			A4 (1:1)
CHKD BY	R.G.KIM	PROJEC'N	3rd Angle	TITLE NAMEPLATE DRAWING		
DSND BY	S.H.LEE	DATE	2024.06.07			



REF. NO	4M-135733	Sheet No.	of
DWG NO	NP-IEEE5-12-215T	Revision No.	0

Type :	PJP
Full Load Torque :	22.1 lb.ft
Load moment of Inertia (J) :	96.700 lb.ft2
Motor moment of Inertia (J) :	1.234 lb.ft2

3.7kW 5HP	6 P	60 Hz
Speed at Full Load :		1180 RPM
Rated Voltage	575V	460V 230V
Full Load Current	6.1A	7.6A 15.3A

SPEED VS TORQUE & CURRENT CURVE

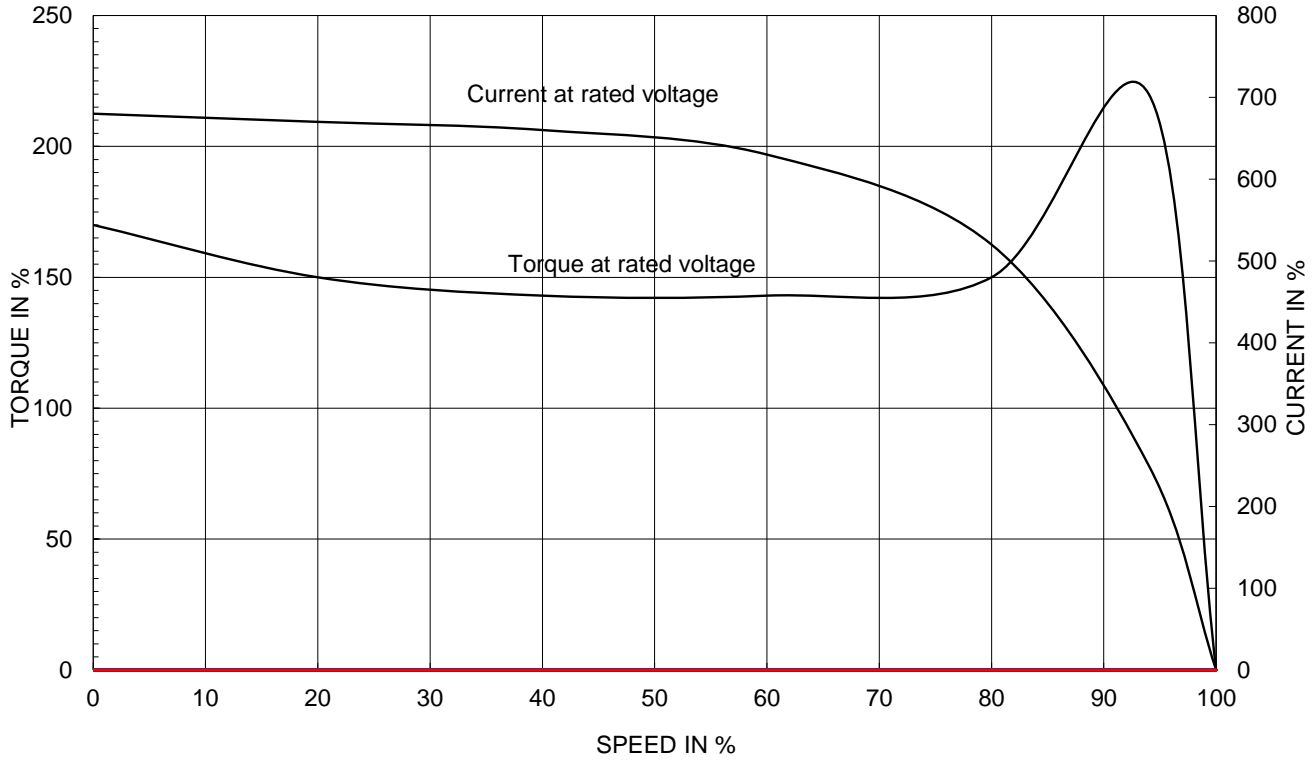

OUTPUT VS EFF., P.F & CURRENT CURVE

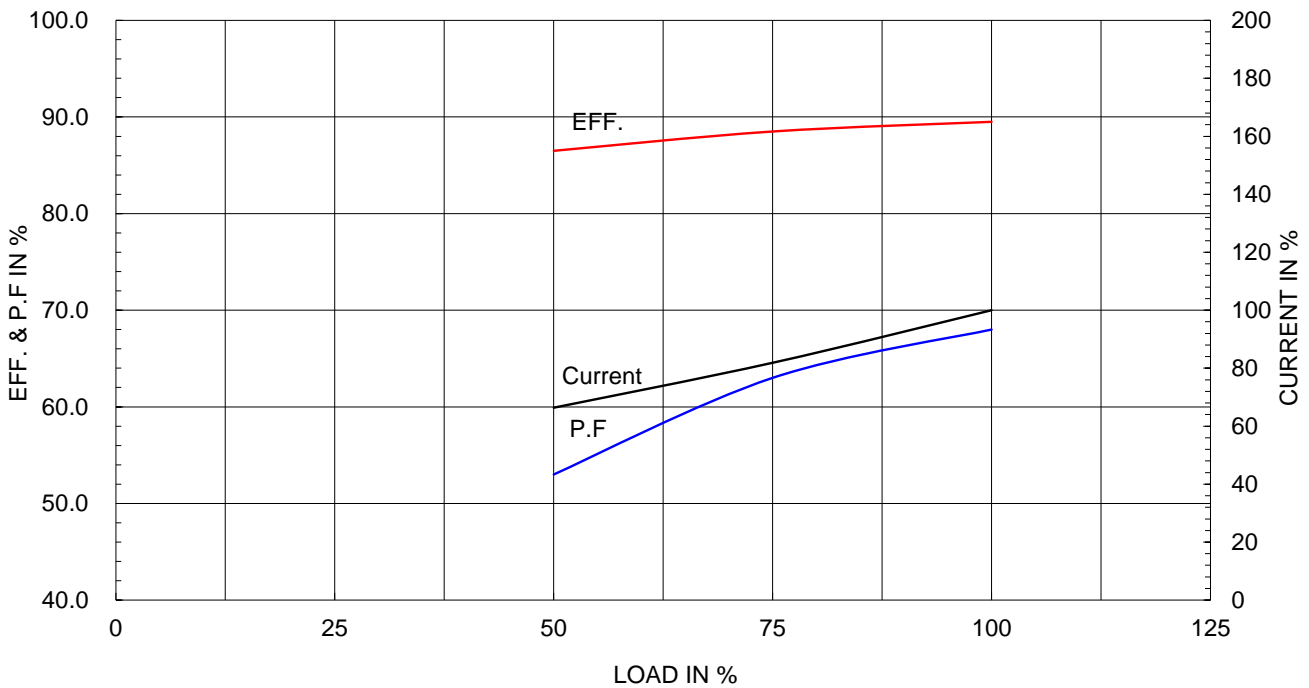

본 도면은 HD현대일렉트릭(주) 재산이며 허가없이 복사할 수 없음 (취급유의)

THIS DRAWING IS PROPRIETARY TO HYUNDAI ELECTRIC. NO PART OF THIS DRAWING MAYBE REPRODUCED WITHOUT THE PERMISSION OF HYUNDAI ELECTRIC.

▽	50S	REV	DATE	CONTENTS	REVD BY	CHKD BY	CHKD BY	APPD BY
▽▽	12.5S							
▽▽▽	3.2S							
▽▽▽▽	0.4S							

IEEE841

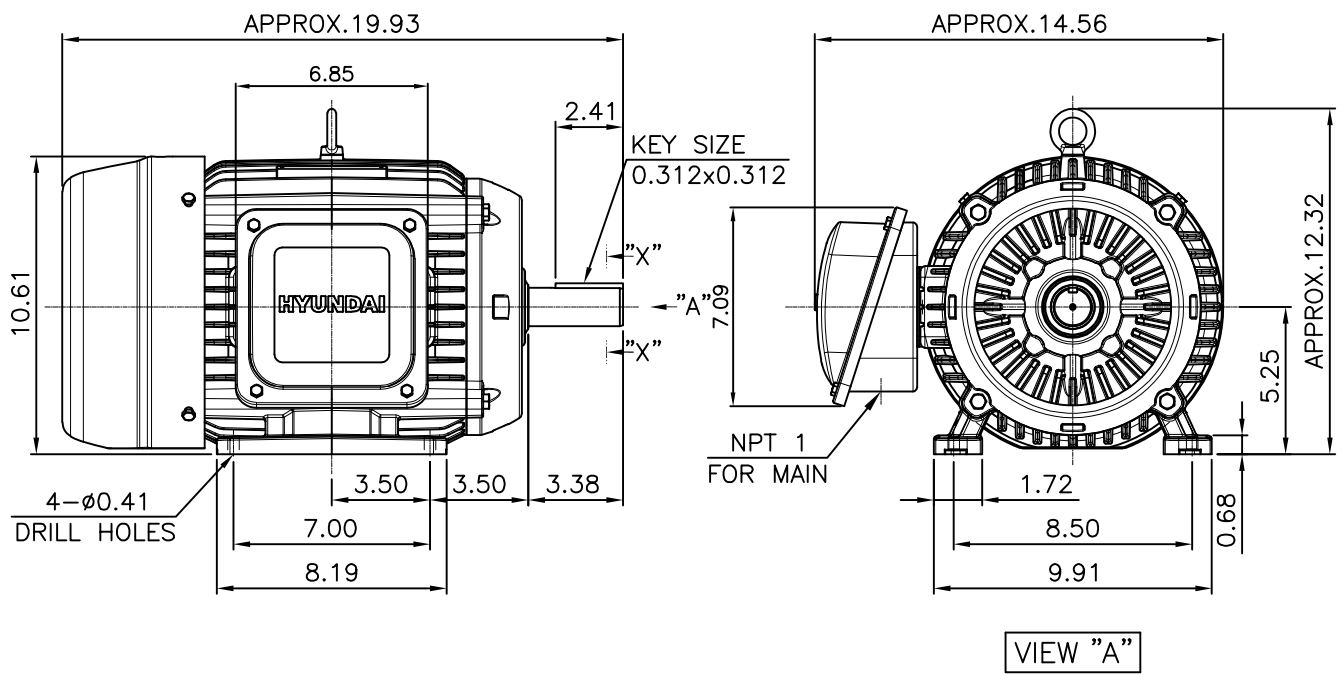

NOTE
[TOLERANCE]

- 1. CENTER HEIGHT : +0.00inch - 0.03inch
- 2. SHAFT DIAMETER : +0.000inch - 0.0005inch
- 3. KEYWAY DEPTH : +0.000inch - 0.015inch

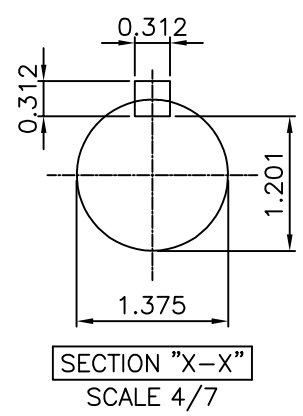

SECTION "X-X"
SCALE 4/7

APPD BY	S.Y.KIM	UNIT	mm	SUBJECT	NEMA 215T	DWG SIZE	
CHKD BY	R.G.KIM	SCALE	1/7	TITLE	OUTLINE	A4 (1:7)	
CHKD BY		PROJEC'N	3rd Angle				
DSND BY	J.H.JEON	DATE	2023.01.18				
				REF. NO	.	Sheet No.	of
				DWG NO	LM-I2215B3PLV23	Revision No.	0

**Cls. I&II, Div. 2
IEEE 841**

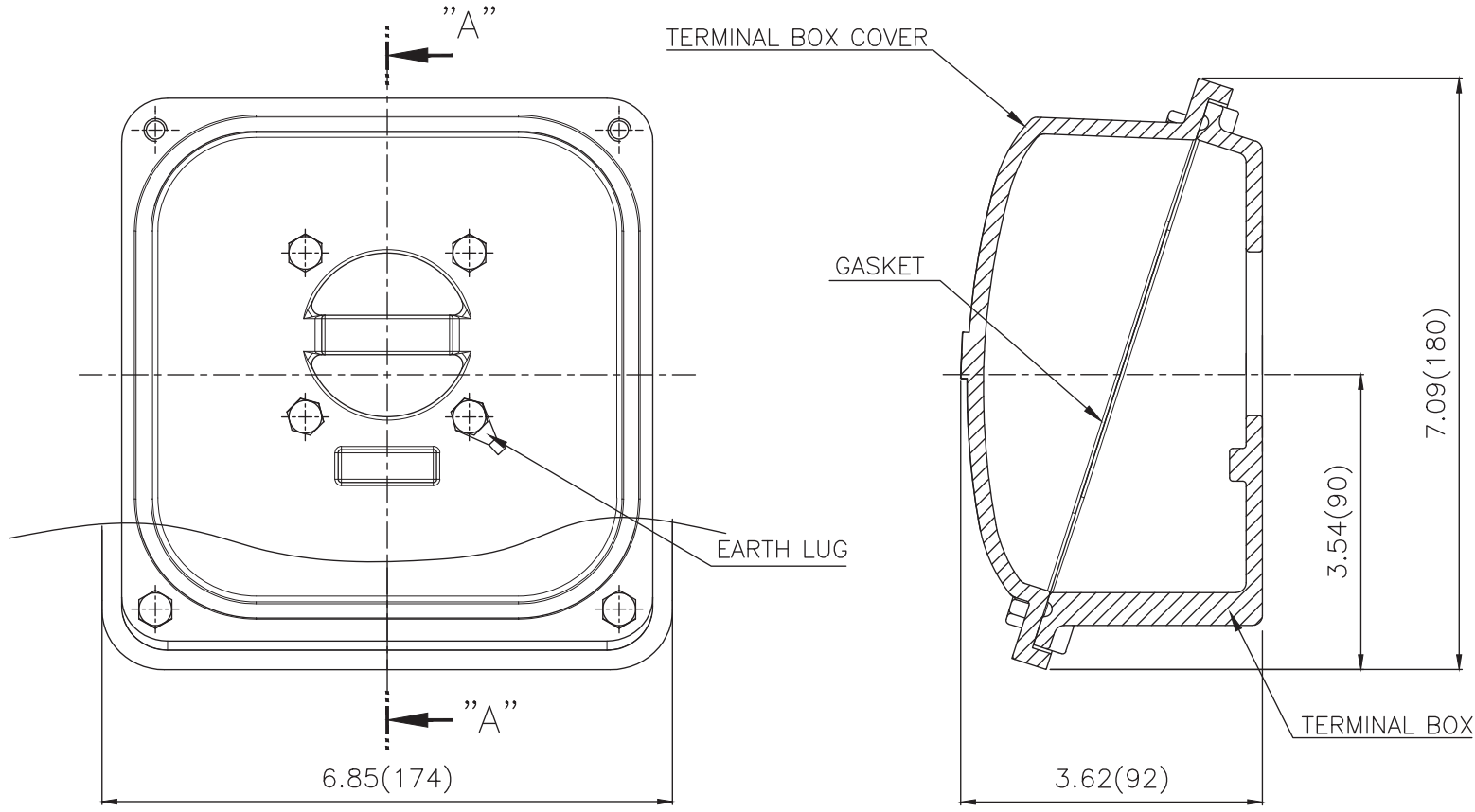

SEC. "A" - "A"

▽	50S
▽▽	12.5S
▽▽▽	3.2S
▽▽▽▽	0.4S

REV	DATE	CONTENTS	REVD BY	CHKD BY	CHKD BY	APPD BY

일반기준공차		일반계관공차	
1-4	±0.1	6-30	±0.5
4-18	±0.2	30-120	±0.8
18-63	±0.3	120-315	±1.2
63-250	±0.5	315-1000	±2.0
250-	±0.8	1000-	±3.0

Q'TY	DESCRIPTION	MATERIAL	DIMENSION	WEIGHT	PART NO.	REMARK	NO.
APPD BY	S.Y.KIM	UNIT	inch(mm)	SUBJECT	FR. 210 (CAST IRON)	DWG SIZE	
CHKD BY		SCALE	1/1.5	TITLE	TERMINAL BOX ASS'Y		
CHKD BY	R.G.KIM	PROJEC'N	3rd Angle	DATE	2023-10-19		
DSND BY	배승희						
REF. NO		Sheet No.	of				
DWG NO	3M-248457	Revision No.	0				

