

Customer :  
Project Name :  
Project No. :  
Revision No. :

# SPECIFICATION for INDUCTION MOTOR



0		For Bidding			
No.	DATE	DESCRIPTION	PREPARED BY	CHECKED BY	APPROVED BY



# AC INDUCTION MOTOR DATA SHEET

## IEEE841 TYPE

Catalog No.	IEEE40-18-324TC	Item No.	Rev. No. [      ]
Project Name		Project No.	Quantity                      sets

GENERAL SPECIFICATION		PERFORMANCE DATA				
Frame Size	324TC	Rated Output	30 kW                      40 HP			
Type	PJP	Number of Poles	4			
Enclosure(Protection)	Totally Enclosed / IP55	Rotor Type	Squirrel Cage			
Method of Cooling	IC411(FC)	Starting Method*	D.O.L			
Rated Frequency	60 Hz	Rated Voltage	575 V	460 V	230 V	
Number of Phases	3	Current	Full Load	39.0 A	48.8 A	97.6 A
Insulation Class	F		Locked-rotor**	850 %	850 %	850 %
Temp. Rise at full load (by resistance method)		Efficiency				
at 1.0 S.F	80 deg. C	50% Load		91.1 %		
Motor Location	<input type="checkbox"/> Indoor <input type="checkbox"/> Outdoor	75% Load		93.1 %		
Altitude	Less than 1,000 meter	100% Load		94.1 %		
Relative Humidity	Less than 80 %	Power Factor(p.u)				
Ambient Temp.	40 deg. C (Max.)	50% Load		0.670		
Duty Type	Continuous ( S1 )	75% Load		0.770		
Service Factor	1.15	100% Load		0.820		
Mounting	B35	Speed at Full Load	1780 r.p.m			
Bearing	Type	Anti-Friction	Torque			
	DE/N-DE	6313ZC3 / 6212ZC3	Full Load	118.7 lb.ft		
	Lubricant	Grease(Polyrex-EM)	Locked-rotor**	170 %		
External Thrust	Not applicable	Breakdown**	220 %			
Coupling Method	<input checked="" type="checkbox"/> Direct <input type="checkbox"/> V-belt	Moment of Inertia (J)				
Shaft Extension	Single	Load(Max.)	218.553 lb.ft2			
Terminal Box	Main	Cast Iron	Motor	7.121 lb.ft2		
	Aux.	No	Sound Pressure Level (No-load & mean value at 1m from motor)			
Location	Refer to Outline Drawing	77 dB(A)				
Application		Vibration	3.8 mm/sec (peak)			
Area classification	Hazardous	Permissible number of consecutive starts	Cold	3 times		
Type of Ex-Protection	Class I&II, Division 2		Hot	2 times		
Applicable Standard	IEEE841, NEMA MG1, CSA C390	Paint	Munsell No.	7.5BG6/1.5		

ACCESSORIES

SUBMITTAL DRAWING		
Outline Dimension Drawing	Motor Weight(Approx.)	
B35	LM-I1326C4PL001	550 lb.

**REMARK**

1. Premium efficiency according to NEMA MG1
2. Inverter Duty @ 1.0 Service Factor & F Temperature rise
  - 10:1 VT (20:1 VT at 50% load)
  - 10:1 CT
  - CHP up to 1.5 times base speed, NEMA MG1 Part31
3. CSA Certification
  - Class I, Division 2, Group A, B, C & D
  - Class II, Division 2 Group E, F & G (Group E : up to 320Fr.)
4. Service Factor 1.15 and Temperature rise B are applicable under the condition of sine wave power.
5. Service Factor 1.25 is applicable to motors of 100HP or less with temperature rise F & Non-Hazardous.

Date	DSND	CHKD	CHKD	APPD
2024-07-13	S.H. Lee	I.K. Kim	R.G. Kim	S.W. Kim

[Note] Others not mentioned in this data sheet shall be in accordance with maker standard.  
 Above technical data are only design values and shall be guaranteed with tolerance of applicable standard.  
 Inspection and performance test shall be done according to maker standard, if not mentioned.  
 \* In case of Inverter-Fed Motor, performance data is based on sine wave tests. It may be different from test data of Inverter combined motor.  
 \*\* Data is based on rated voltage & frequency and is expressed as a percentage of full-load value.

본 도면은 HD현대일렉트릭(주) 재산이며 허가없이 복사할 수 없음 (취급주의)

THIS DRAWING IS PROPRIETARY TO HYUNDAI ELECTRIC. NO PART OF THIS DRAWING MAYBE REPRODUCED WITHOUT THE PERMISSION OF HYUNDAI ELECTRIC.

1	2	3	4
REV	DATE	CONTENTS	REVD BY   CHKD BY   CHKD BY   APPD BY

4.72

## CROWN TRITON

Premium Efficiency AC 3 Phase Motor



40HP	4P	460V	Cat. No.	IEEE40-18-324TC				
Model	HLS324PR23		INS. Class	F	HD-F1	Amps	48.8	
Type	HLS	Duty	CONT	Code	K	Amb.	40°C	
Frame	324TC	Encl.	TEFC	S.F.	1.15	RPM	1780	
Bearing	Drive	6313ZC3		S.F.1.00 (10:1 C.T., 20:1 V.T., NEMA-MG1 Part31)		3/4 Eff.	93.1%	
	Opp.	6212ZC3				NEMA Design	B Torque	
Usable at	50Hz 30HP 380V 49.9A 1480rpm S.F.: 1.0 Eff.: 91.6% Code: L							
	50Hz 30HP 400/415V 48.7/48.1A 1485/1485rpm S.F.: 1.0 Eff.: 91.6/91.6% Code: L/L							
CSA Certified for	Model	LATER		Type	PJP	Temp. Code		
	CLASS I, Div. 2, Gr. A, B, C & D		CLASS II, Div. 2, Gr. E, F & G (Gr. E : Up to 320FR)		Frame	140~320FR	360~400FR	440FR
	CLASS I, Zone 2, Gr. IIA, IIB, & IIC				Amb. 40°C	T3C (160°C)	T3B (165°C)	T3A (180°C)
					Amb. 55°C	T3A (180°C)	T3A (180°C)	T3 (200°C)
No.	-		Date	-		Weight	550 lb	

**IEEE Std 841-2021**

4M-135701

**MARINE DUTY IEEE45**

Made in Korea H1



2.36

APPD BY	S.Y.KIM	UNIT	INCH	SUBJECT	CSA Class I, Division2 IEEE841 (HL)	DWG SIZE
CHKD BY	I.K.KIM	SCALE	NONE			A4 ( 1:1 )
CHKD BY	R.G.KIM	PROJEC'N	3rd Angle	TITLE <b>NAMEPLATE DRAWING</b>		
DSND BY	S.H.LEE	DATE	2024.06.07			
				REF. NO	<b>4M-135701</b>	Sheet No. of
				DWG NO	<b>NP-IEEE40-18-324TC</b>	Revision No. <b>0</b>

Type :	PJP
Full Load Torque :	118.7 lb.ft
Load moment of Inertia (J) :	218.553 lb.ft2
Motor moment of Inertia (J) :	7.121 lb.ft2

30kW	40HP	4 P	60 Hz
Speed at Full Load :			1780 RPM
Rated Voltage	575V	460V	230V
Full Load Current	39.0A	48.8A	97.6A

SPEED VS TORQUE & CURRENT CURVE

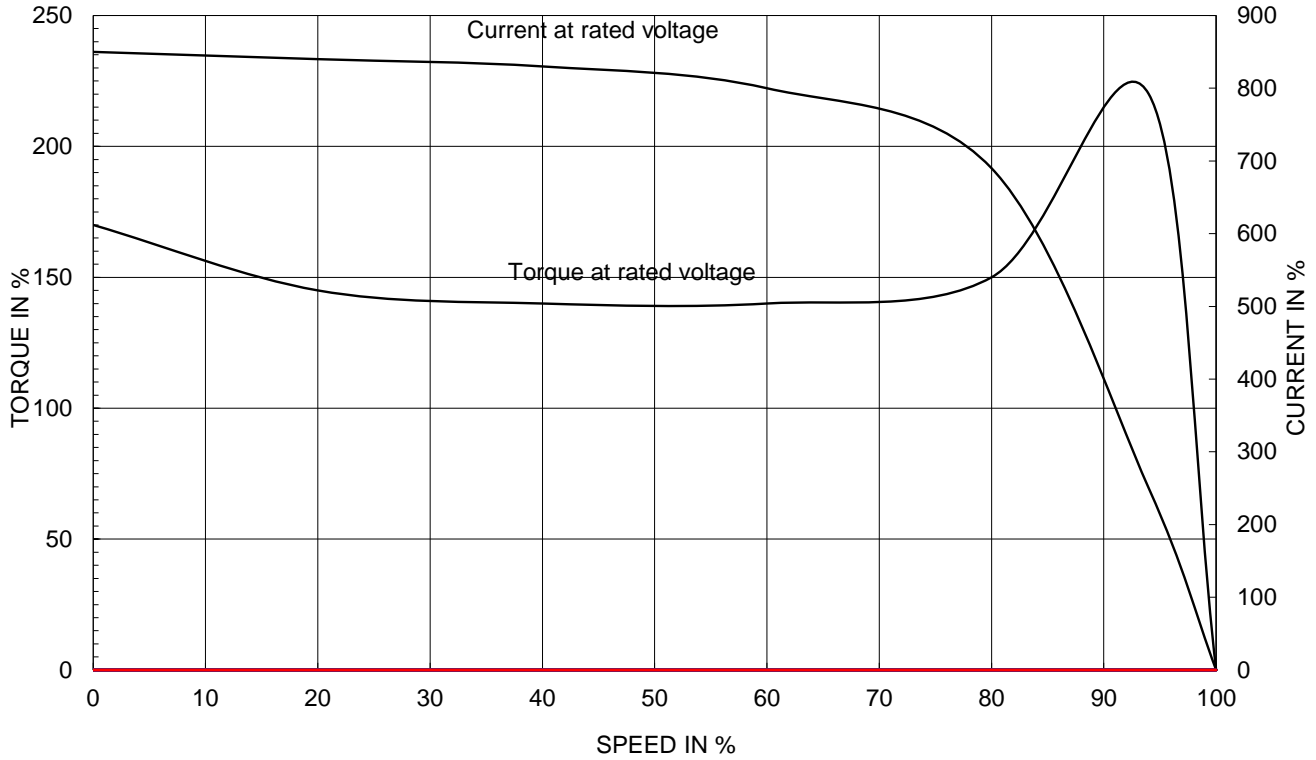

OUTPUT VS EFF., P.F & CURRENT CURVE

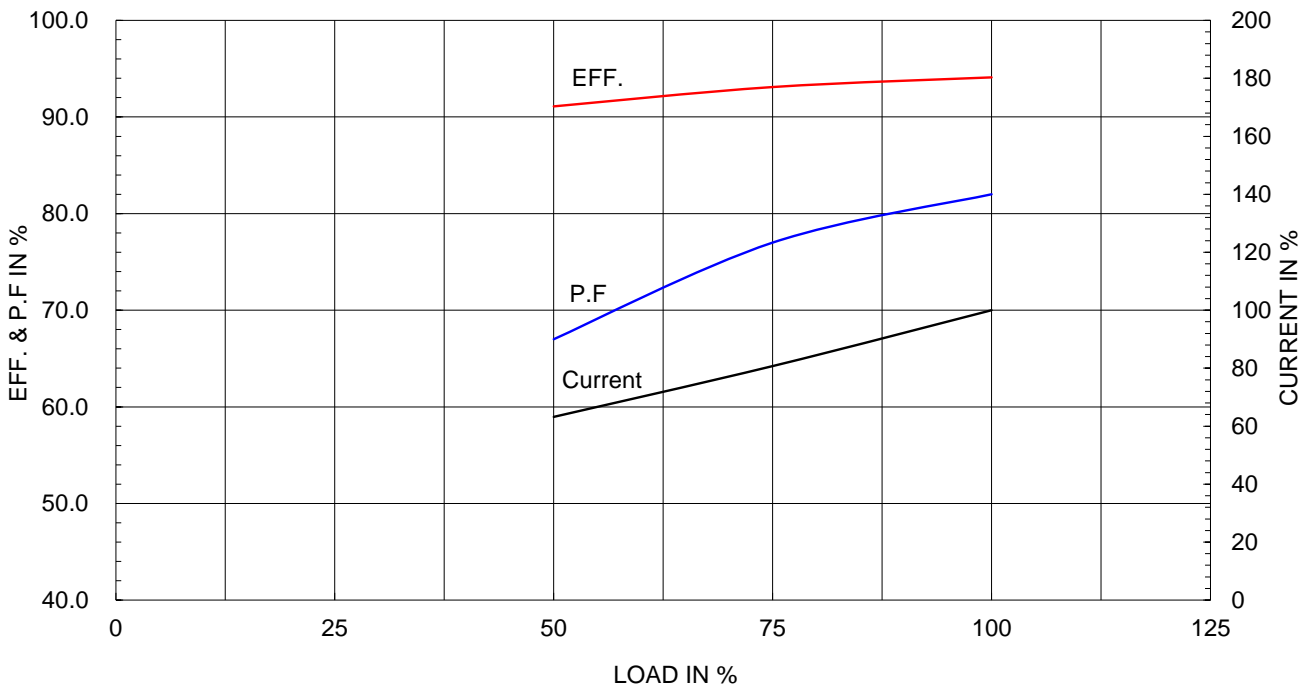

본 도면은 HD현대일렉트릭(주) 재산이며 허가없이 복사할 수 없음 (취급주의)

THIS DRAWING IS PROPRIETARY TO HYUNDAI ELECTRIC. NO PART OF THIS DRAWING MAYBE REPRODUCED WITHOUT THE PERMISSION OF HYUNDAI ELECTRIC.

▽	50S	REV	DATE	CONTENTS	REVD BY	CHKD BY	CHKD BY	APPD BY
▽▽	12.5S							
▽▽▽	3.2S							
▽▽▽▽	0.4S							

**IEEE841**

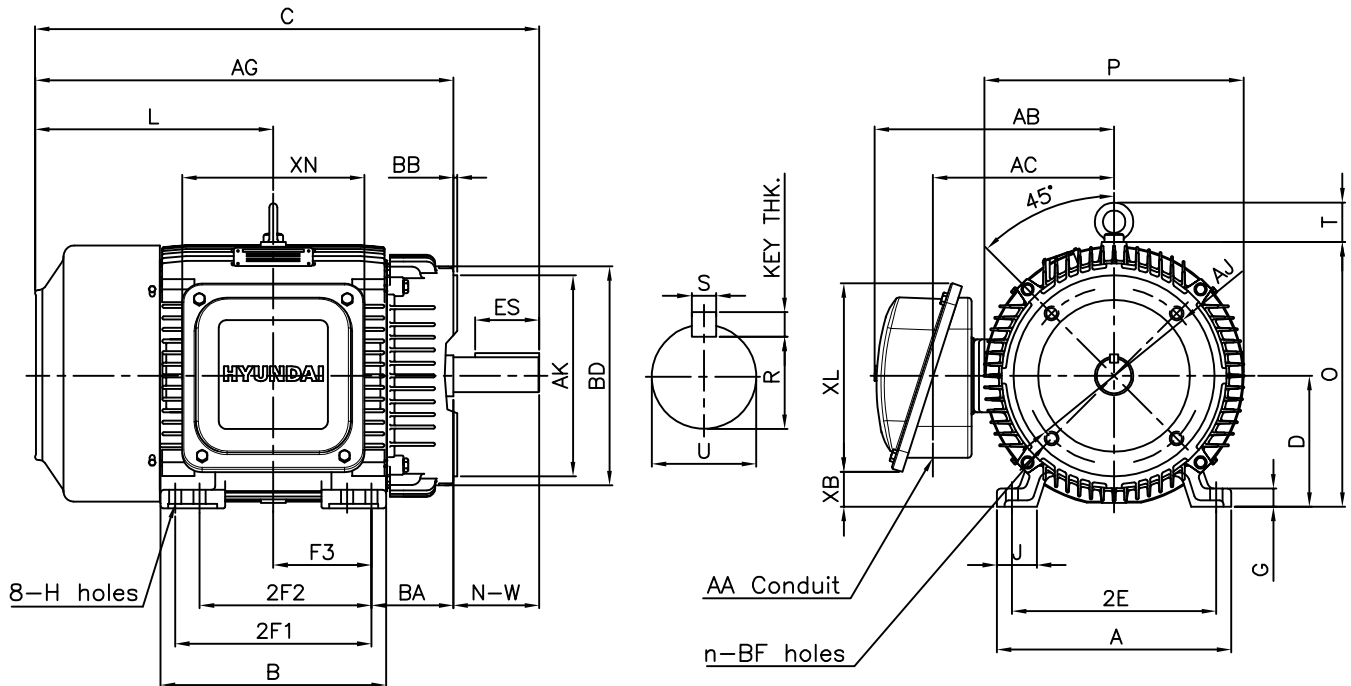

DIMENSIONS

Unit : inch

F L A N G E						M O U N T I N G								
AJ	AK	BD	BB	BF	n	A	B	2E	2F1 <sup>5)</sup>	2F2 <sup>4)</sup>	F3	G	J	H
11.0	12.50	13.27	0.25	5/8-11	4	14.33	13.78	12.50	12.00	10.50	6.00	1.11	2.36	0.66

C O N D U I T B O X						O V E R A L L						APPROX. WGT.(LB)			
AA	AB	AC	XB	XL	XN	AG	BA	C	D	L	O	P	T	324T	326T
2.00	15.31	11.14	2.13	11.38	11.14	26.21	5.25	31.46	8.00	14.60	16.19	15.84	2.41	550	560

S H A F T					KEY THK.	B E A R I N G	
U	N-W	KEYWAY				DRIVE END	OPP. DRIVE END
		R	ES	S			
2.125	5.25	1.845	3.91	0.500	0.500	6313ZC3	6211ZC3

**NOTE**

- 1.Dimension "D" tolerance : +0.00inch - 0.03inch
- 2.Dimension "U" tolerance : +0.000inch - 0.001inch
- 3.Dimension "R" tolerance : +0.000inch - 0.015inch
- 4.Location of holes for 324TC frame
- 5.Location of holes for 326TC frame

APPD BY	S.Y.KIM	UNIT	INCH	SUBJECT	NEMA 324TC/326TC	DWG SIZE	A4 ( 1:1 )	
CHKD BY	R.G.KIM	SCALE	NONE					
CHKD BY	Y.H.BAE	PROJEC'N	3각법(3rd Angle)	TITLE				OUTLINE
DSND BY	H.K.LEE	DATE	2021-05-06					



REF. NO	350A8312AA	Sheet No.	of
DWG NO	LM-I1326C4PL001	Revision No.	0



**Cls. I&II, Div. 2  
IEEE 841**

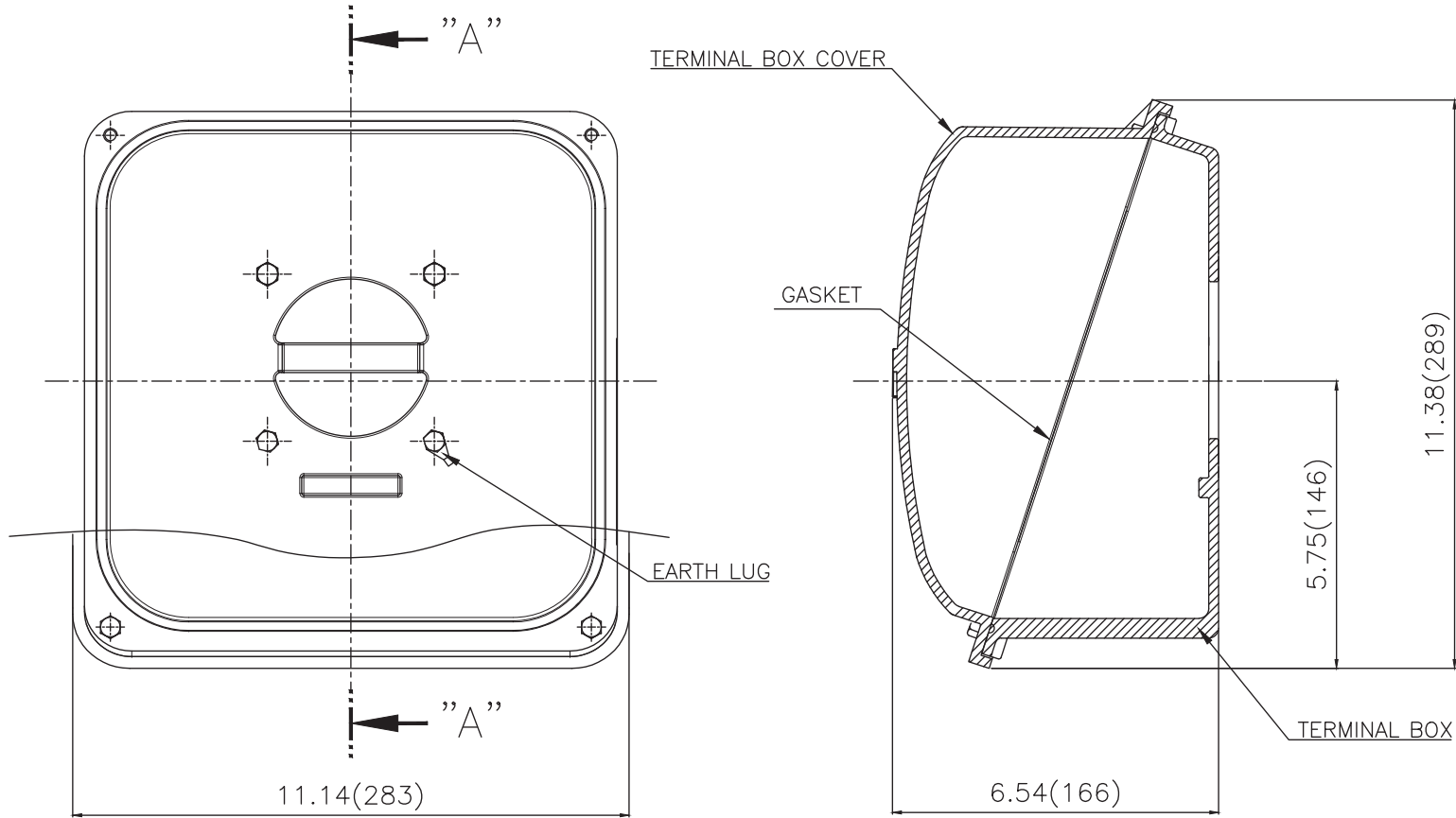

SEC. "A"-"A"

▽	50S
▽▽	12.5S
▽▽▽	3.2S
▽▽▽▽	0.4S

REV	DATE	CONTENTS	REVD BY	CHKD BY	CHKD BY	APPD BY

일반가공공차		일반재공공차	
1-4	±0.1	6-30	±0.5
4-18	±0.2	30-120	±0.8
18-63	±0.3	120-315	±1.2
63-250	±0.5	315-1000	±2.0
250-	±0.8	1000-	±3.0

Q'TY	DESCRIPTION	MATERIAL	DIMENSION	WEIGHT	PART NO.	REMARK	NO.
APPD BY	S.Y.KIM	UNIT	inch(mm)	SUBJECT	FR. 320 (CAST IRON)	DWG SIZE	
CHKD BY		SCALE	1/2.5	TITLE	TERMINAL BOX ASS'Y		
CHKD BY	R.G.KIM	PROJEC'N	3rd Angle	DATE	2023-10-19		
DSND BY	배승희	DATE					
REF. NO		Sheet No.	of				
DWG NO	3M-248459	Revision No.	0				

