

Customer :
Project Name :
Project No. :
Revision No. :

SPECIFICATION for INDUCTION MOTOR



0		For Bidding			
No.	DATE	DESCRIPTION	PREPARED BY	CHECKED BY	APPROVED BY



AC INDUCTION MOTOR DATA SHEET

IEEE841 TYPE

Catalog No.	IEEE350-36-L449TS-IBBRSRSHSP	Item No.		Rev. No.	[]
Project Name		Project No.		Quantity	sets

GENERAL SPECIFICATION			PERFORMANCE DATA			
Frame Size	L449TS		Rated Output	260 kW 350 HP		
Type	PJP		Number of Poles	2		
Enclosure(Protection)	Totally Enclosed	/ IP55	Rotor Type	Squirrel Cage		
Method of Cooling	IC411(FC)		Starting Method*	D.O.L		
Rated Frequency	60 Hz		Rated Voltage	575 V	460 V	230 V
Number of Phases	3		Current	Full Load	302.8 A	378.5 A 757.0 A
Insulation Class	F			Locked-rotor**	700 %	700 % 700 %
Temp. Rise at full load (by resistance method)			Efficiency			
at 1.0 S.F			80 deg. C		50% Load 92.8 %	
Motor Location	<input type="checkbox"/> Indoor <input type="checkbox"/> Outdoor		75% Load		94.8 %	
Altitude	Less than 1,000 meter		100% Load		95.8 %	
Relative Humidity	Less than 80 %		Power Factor(p.u)			
Ambient Temp.	40 deg. C (Max.)		50% Load		0.750	
Duty Type	Continuous (S1)		75% Load		0.850	
Service Factor	1.15		100% Load		0.900	
Mounting	B3		Speed at Full Load	3570 r.p.m		
Bearing	Type	Anti-Friction	Torque			
	DE/N-DE	6315C3 / 6315C3-INS.	Full Load	513.1 lb.ft		
	Lubricant	Grease(Polyrex-EM)	Locked-rotor**	130 %		
External Thrust	Not applicable		Breakdown**	225 %		
Coupling Method	<input checked="" type="checkbox"/> Direct <input type="checkbox"/> V-belt		Moment of Inertia (J)			
Shaft Extension	Single		Load(Max.)	281.000 lb.ft2		
Terminal Box	Main	Cast Iron	Motor	50.550 lb.ft2		
	Aux.	Yes	Sound Pressure Level (No-load & mean value at 1m from motor)			
Location	Refer to Outline Drawing		87 dB(A)			
Application			Vibration 3.8 mm/sec (peak)			
Area classification	Hazardous		Permissible number of consecutive starts	Cold	2 times	
Type of Ex-Protection	Class I&II, Division 2			Hot	1 time	
Applicable Standard	IEEE841, NEMA MG1, CSA C390		Paint	Munsell No.	7.5BG6/1.5	

ACCESSORIES
*. B.T.D.(Pt 100 Ω at 0°C,Single) : 2EA/Motor
*. W.T.D.(Pt 100 Ω at 0°C) : 2EA/Ph.
*. Space Heater : 1EA/Motor

SPARE PARTS
1. Spare Axial Fan (C.W Direction)

SUBMITTAL DRAWING		
Outline Dimension Drawing	\ Motor Weight(Approx.)	
B3	LM-I044XB3C7001	3090 lb.

REMARK
1. Premium efficiency according to NEMA MG1
2. Inverter Duty @ 1.0 Service Factor & F Temperature rise
- . 10:1 VT (20:1 VT at 50% load)
- . 10:1 CT
- . CHp up to 1.5 times base speed, NEMA MG1 Part31
3. NDE side : Insulated bearing
4. CSA Certification
- . Class I, Division 2, Group A, B, C & D; Temp code : T3
- . Class II, Division 2 Group F & G; Temp code : T3
5. Uni-directional CCW viewed from drive end.

Date	DSND	CHKD	CHKD	APPD
2024-07-13	S.H. Lee	I.K. Kim	R.G. Kim	S.W. Kim





[Note] Others not mentioned in this data sheet shall be in accordance with maker standard.
 Above technical data are only design values and shall be guaranteed with tolerance of applicable standard.
 Inspection and performance test shall be done according to maker standard, if not mentioned.
 * In case of Inverter-Fed Motor, performance data is based on sine wave tests. It may be different from test data of Inverter combined motor.
 ** Data is based on rated voltage & frequency and is expressed as a percentage of full-load value.

1	2	3	4
REV	DATE	CONTENTS	REVD BY

4.72

CROWN TRITON

Premium Efficiency AC 3 Phase Motor

350HP 2P 460V		Cat. No. IEE350-36-L449TS-IBBRSRSHSP	
Model	LATER	INS. Class	F
Type	PJP	Duty	CONT
Frame	L449TS	Encl.	TEFC
Bearing	Drive	6315C3	S.F. 1.15
	Opp.	6315C3-INS.	
Usable at		S.F. 1.00 (10:1 C.T., 20:1 V.T., NEMA-MG1 Part31)	
CSA Certified for	CLASS I, Div. 2, Gr. A, B, C & D		Temp. Code (sine wave)
	CLASS I, Zone 2, Gr. IIA, IIB, & IIC		
	CLASS II, Div. 2, Gr. F & G		
No.	-	Date	-
IEEE Std 841-2021		MARINE DUTY IEEE45	
4M-136054		Made in Korea H1	



2.36

APPD BY	S.Y.KIM	UNIT	INCH	SUBJECT	CSA Class I, Division2 IEEE841 (XL)	DWG SIZE
CHKD BY	I.K.KIM	SCALE	NONE			A4 (1:1)
CHKD BY	R.G.KIM	PROJEC'N	3rd Angle	TITLE NAMEPLATE DRAWING		
DSND BY	S.H.LEE	DATE	2024.06.07			
				REF. NO	4M-136054	Sheet No. of
				DWG NO	NP-IEEE350-36-L449TS-IBBRSRSHSP	Revision No. 0

Type :	PJP
Full Load Torque :	513.1 lb.ft
Load moment of Inertia (J) :	281.000 lb.ft2
Motor moment of Inertia (J) :	50.550 lb.ft2

260kW	350HP	2 P	60 Hz
Speed at Full Load :			3570 RPM
Rated Voltage	575V	460V	230V
Full Load Current	302.8A	378.5A	757.0A

SPEED VS TORQUE & CURRENT CURVE

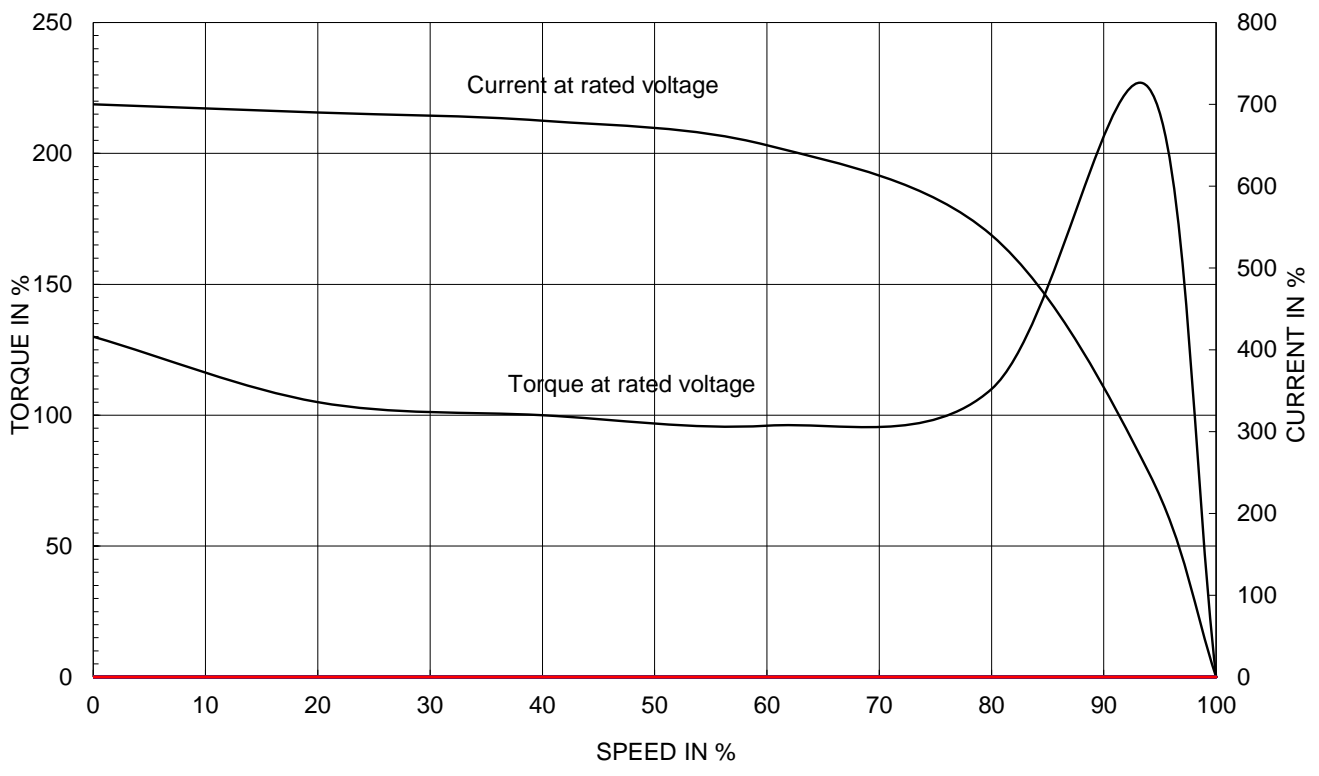

OUTPUT VS EFF., P.F & CURRENT CURVE

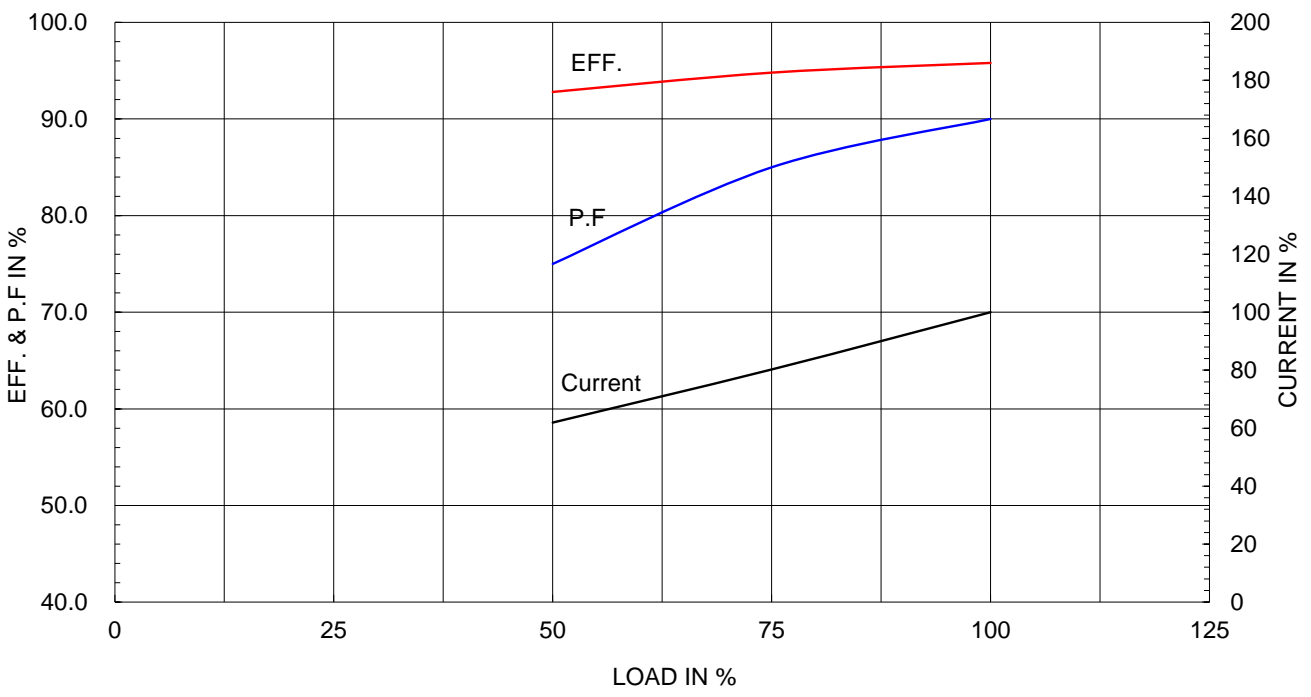

본 도면은 HD현대일렉트릭(주) 재산이며 허가없이 복사할 수 없음 (취급주의)

THIS DRAWING IS PROPRIETARY TO HYUNDAI ELECTRIC. NO PART OF THIS DRAWING MAYBE REPRODUCED WITHOUT THE PERMISSION OF HYUNDAI ELECTRIC.

▽	50S	REV	DATE	CONTENTS	REVD BY	CHKD BY	CHKD BY	APPD BY
▽▽	12.5S							
▽▽▽	3.2S							
▽▽▽▽	0.4S							

IEEE841

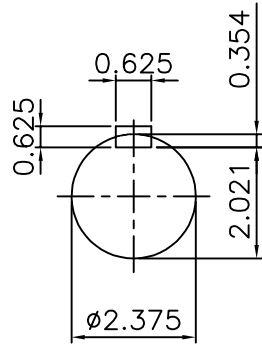
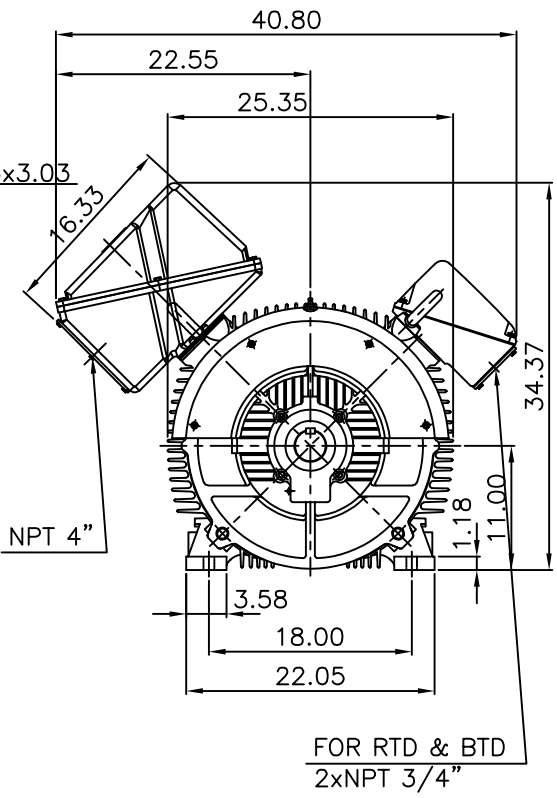
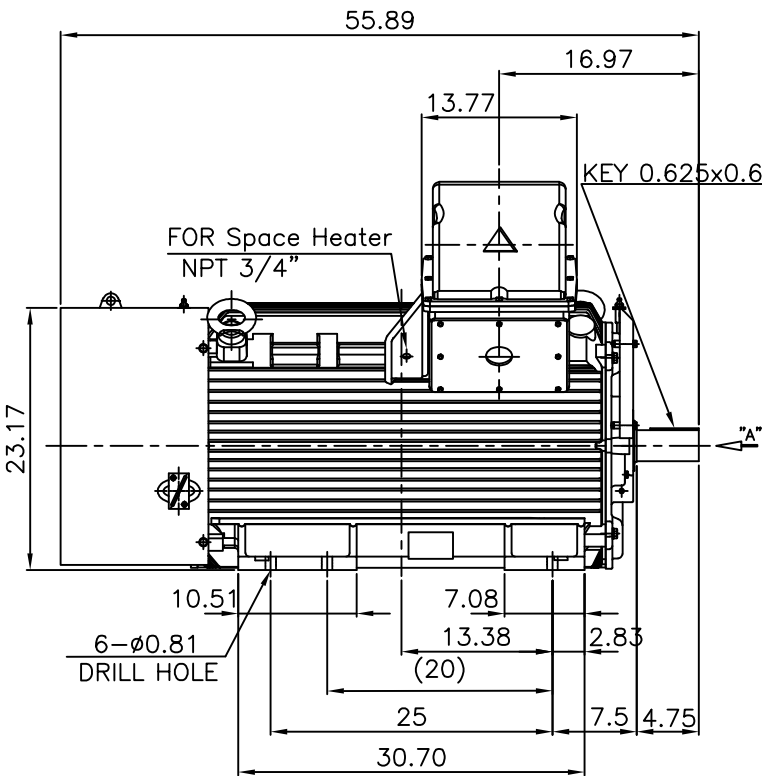

VIEW "A"

NOTE

1.TOLERANCE :

CENTER HEIGHT	11	+0.000	-0.060
SHAFT DIAMETER	ø2.375	+0.000	-0.001
KEYWAY WIDTH	0.625	+0.002	-0.000

APPD BY	S.Y.KIM	UNIT	INCH	SUBJECT	Fr.L449TS	DWG SIZE	A4 (1:18)
CHKD BY	O.J.KIM	SCALE	1/18	TITLE	NEMA STD SHAFT(AISI 1045 SHAFT)		
CHKD BY	R.G.KIM	PROJEC'N	3각법(3rd Angle)	OUTLINE			
DSND BY	H.K.LEE	DATE	2021-04-27				
HD HYUNDAI ELECTRIC				REF. NO		Sheet No.	of
				DWG NO	LM-1044XB3C7001	Revision No.	0

**Cls. I&II, Div. 2
IEEE 841**



SEC. "A" - "A"

REV	DATE	CONTENTS	REVD BY	CHKD BY	CHKD BY	APPD BY

APPD BY	S.Y.KIM	UNIT	inch(mm)	SUBJECT	FR. L440 (CAST IRON)	DWG SIZE
CHKD BY		SCALE	1/3.5	TITLE	MAIN TERMINAL BOX ASS'Y	A3 (1:3.5)
CHKD BY	R.G.KIM	PROJEC'N	3rd Angle			
DSND BY	최승희	DATE	2023-10-19			
				REF. NO		Sheet No. of
				DWG NO	3M-248452	Revision No. 0

**Cls. I&II, Div. 2
IEEE 841**

본 도면은 HD현대일렉트릭(주) 재산이며
허가없이 복사할 수 없음 (취급주의)

THIS DRAWING IS PROPRIETARY TO HYUNDAI ELECTRIC. NO PART OF THIS DRAWING
MAY BE REPRODUCED WITHOUT THE PERMISSION OF HYUNDAI ELECTRIC.



REV	DATE	CONTENTS	REVD BY	CHKD BY	CHKD BY	APPD BY

APPD BY	S.Y.KIM	UNIT	inch(mm)	SUBJECT	FR.360 (CAST IRON)	DWG SIZE	A3 (1:2.2)
CHKD BY		SCALE	1/1	TITLE	AUX. TERMINAL BOX ASS'Y	REF. NO	Sheet No. of
CHKD BY	R.G.KIM	PROJEC'N	3rd Angle	DWG NO		3M-165277	Revision No.
DSND BY	박승희	DATE	2024-01-18				

**Cls. I&II, Div. 2
IEEE 841**



REV	DATE	CONTENTS	REVD BY	CHKD BY	CHKD BY	APPD BY

APPD BY	S.Y.KIM	UNIT	inch(mm)	SUBJECT	FR.180 (CAST IRON)	DWG SIZE	A3 (1:1.1)
CHKD BY		SCALE	1/1	TITLE	SUB. TERMINAL BOX ASS'Y		
CHKD BY	R.G.KIM	PROJEC'N	3rd Angle	REF. NO		Sheet No.	of
DSND BY	배승희	DATE	2024-01-18	DWG NO	3M-165278	Revision No.	0

