

Customer :  
Project Name :  
Project No. :  
Revision No. :

# SPECIFICATION for INDUCTION MOTOR



0		For Bidding			
No.	DATE	DESCRIPTION	PREPARED BY	CHECKED BY	APPROVED BY



# AC INDUCTION MOTOR DATA SHEET

## IEEE841 TYPE

Catalog No.	IEEE30-18-286TCRD	Item No.	Rev. No. [      ]
Project Name		Project No.	Quantity                      sets

GENERAL SPECIFICATION		PERFORMANCE DATA			
Frame Size	286TC	Rated Output	22 kW                      30 HP		
Type	PJP	Number of Poles	4		
Enclosure(Protection)	Totally Enclosed / IP55	Rotor Type	Squirrel Cage		
Method of Cooling	IC411(FC)	Starting Method*	D.O.L		
Rated Frequency	60 Hz	Rated Voltage	575 V	460 V	230 V
Number of Phases	3	Current	Full Load	29.1 A	36.4 A
Insulation Class	F		Locked-rotor**	740 %	740 %
Temp. Rise at full load (by resistance method)		Efficiency			
at 1.0 S.F	80 deg. C	50% Load		90.6 %	
Motor Location	<input type="checkbox"/> Indoor <input type="checkbox"/> Outdoor	75% Load		92.6 %	
Altitude	Less than 1,000 meter	100% Load		93.6 %	
Relative Humidity	Less than 80 %	Power Factor(p.u)			
Ambient Temp.	40 deg. C (Max.)	50% Load		0.660	
Duty Type	Continuous ( S1 )	75% Load		0.760	
Service Factor	1.15	100% Load		0.810	
Mounting	B5	Speed at Full Load	1775 r.p.m		
Bearing	Type	Anti-Friction	Torque		
	DE/N-DE	6310ZC3 / 6310ZC3	Full Load	87.3 lb.ft	
	Lubricant	Grease(Polyrex-EM)	Locked-rotor**	170 %	
External Thrust	Not applicable	Breakdown**	220 %		
Coupling Method	<input checked="" type="checkbox"/> Direct <input type="checkbox"/> V-belt	Moment of Inertia (J)			
Shaft Extension	Single	Load(Max.)	160.272 lb.ft2		
Terminal Box	Main	Cast Iron	Motor	5.578 lb.ft2	
	Aux.	No	Sound Pressure Level (No-load & mean value at 1m from motor)		
Location	Refer to Outline Drawing			77 dB(A)	
Application		Vibration		3.8 mm/sec (peak)	
Area classification	Hazardous	Permissible number of consecutive starts	Cold	3 times	
Type of Ex-Protection	Class I&II, Division 2		Hot	2 times	
Applicable Standard	IEEE841, NEMA MG1, CSA C390	Paint	Munsell No.	7.5BG6/1.5	

ACCESSORIES

SUBMITTAL DRAWING		
Outline Dimension Drawing	Motor Weight(Approx.)	
B5	LM-I1286C5PL001	410 lb.

SPARE PARTS

REMARK				
1. Premium efficiency according to NEMA MG1 2. Inverter Duty @ 1.0 Service Factor & F Temperature rise -. 10:1 VT (20:1 VT at 50% load) -. 10:1 CT -. CHP up to 1.5 times base speed, NEMA MG1 Part31 3. CSA Certification -. Class I, Division 2, Group A, B, C & D -. Class II, Division 2 Group E, F & G (Group E : up to 320Fr.) 4. Service Factor 1.15 and Temperature rise B are applicable under the condition of sine wave power. 5. Service Factor 1.25 is applicable to motors of 100HP or less with temperature rise F & Non-Hazardous.				
Date	DSND	CHKD	CHKD	APPD
2024-07-13	S.H. Lee	I.K. Kim	R.G. Kim	S.W. Kim

[Note] Others not mentioned in this data sheet shall be in accordance with maker standard.  
 Above technical data are only design values and shall be guaranteed with tolerance of applicable standard.  
 Inspection and performance test shall be done according to maker standard, if not mentioned.  
 \* In case of Inverter-Fed Motor, performance data is based on sine wave tests. It may be different from test data of Inverter combined motor.  
 \*\* Data is based on rated voltage & frequency and is expressed as a percentage of full-load value.

1	2	3	4
REV	DATE	CONTENTS	REVD BY   CHKD BY   CHKD BY   APPD BY

4.72

## CROWN TRITON

Premium Efficiency AC 3 Phase Motor

30HP	4P	460V	Cat. No.	IEEE30-18-286TCRD				
Model	HLS286PR23		INS. Class	F	HD-F1	Amps	36.4	
Type	HLS	Duty	CONT	Code	J	Amb.	40°C	
Frame	286TC	Encl.	TEFC	S.F.	1.15	RPM	1775	
Bearing	Drive	6310ZC3		S.F.1.00 (10:1 C.T., 20:1 V.T., NEMA-MG1 Part31)		3/4 Eff.	92.6%	
	Opp.	6310ZC3				NEMA Design	B Torque	
Usable at	50Hz 25HP 380V 42.4A 1475rpm S.F.: 1.0 Eff.: 91.2% Code: J							
	50Hz 25HP 400/415V 42.3/43.1A 1480/1480rpm S.F.: 1.0 Eff.: 91.2/91.2% Code: K/L							
CSA Certified for	Model	LATER		Type	PJP	Temp. Code		
	CLASS I, Div. 2, Gr. A, B, C & D		CLASS II, Div. 2, Gr. E, F & G (Gr. E : Up to 320FR)		Frame	140~320FR	360~400FR	440FR
	CLASS I, Zone 2, Gr. IIA, IIB, & IIC				Amb. 40°C	T3C (160°C)	T3B (165°C)	T3A (180°C)
					Amb. 55°C	T3A (180°C)	T3A (180°C)	T3 (200°C)
No.	-		Date	-		Weight	410 lb	

**IEEE Std 841-2021**

4M-135701

**MARINE DUTY IEEE45**

Made in Korea H1

2.36

APPD BY	S.Y.KIM	UNIT	INCH	SUBJECT	CSA Class I, Division2 IEEE841 (HL)	DWG SIZE	A4 ( 1:1 )
CHKD BY	I.K.KIM	SCALE	NONE				
CHKD BY	R.G.KIM	PROJEC'N	3rd Angle	TITLE <b>NAMEPLATE DRAWING</b>			
DSND BY	S.H.LEE	DATE	2024.06.07				
				REF. NO	<b>4M-135701</b>	Sheet No. of	
				DWG NO	<b>NP-IEEE30-18-286TCRD</b>	Revision No. <b>0</b>	

Type :	PJP
Full Load Torque :	87.3 lb.ft
Load moment of Inertia (J) :	160.272 lb.ft2
Motor moment of Inertia (J) :	5.578 lb.ft2

22kW 30HP	4 P	60 Hz
Speed at Full Load :		1775 RPM
Rated Voltage	575V	460V 230V
Full Load Current	29.1A	36.4A 72.8A

SPEED VS TORQUE & CURRENT CURVE

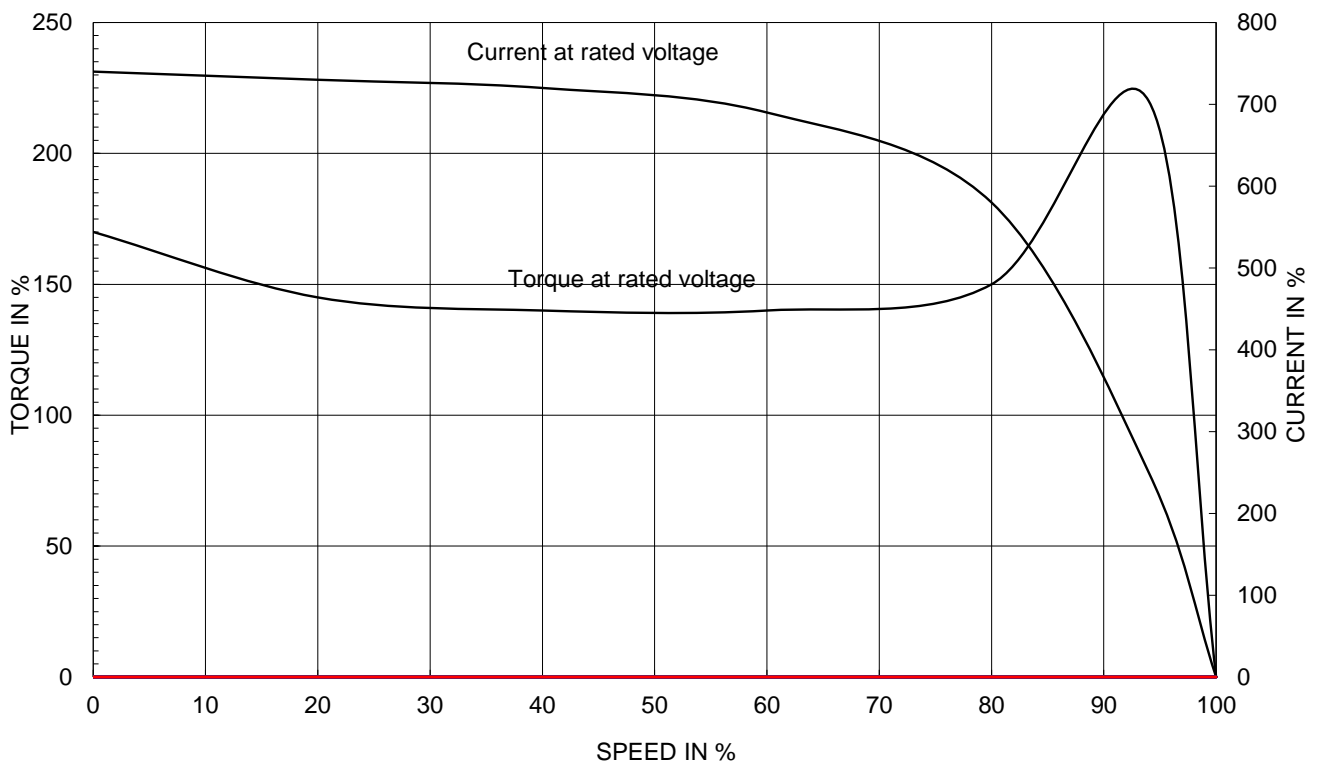

OUTPUT VS EFF., P.F & CURRENT CURVE

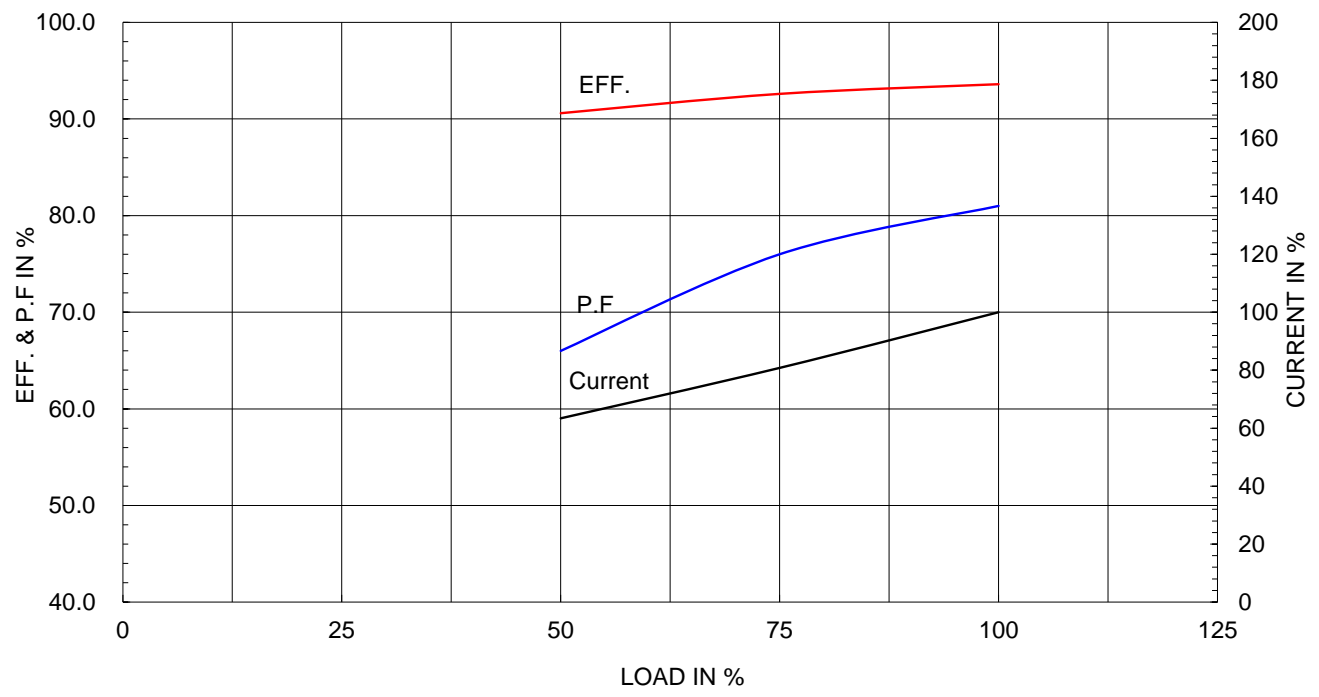

본 도면은 HD현대일렉트릭(주) 재산이며 허가없이 복사할 수 없음 (취급주의)

THIS DRAWING IS PROPRIETARY TO HYUNDAI ELECTRIC. NO PART OF THIS DRAWING MAYBE REPRODUCED WITHOUT THE PERMISSION OF HYUNDAI ELECTRIC.

1	2	3	4
▽	50S	REV	DATE
▽▽	12.5S		
▽▽▽	3.2S		
▽▽▽▽	0.4S		

**IEEE841**

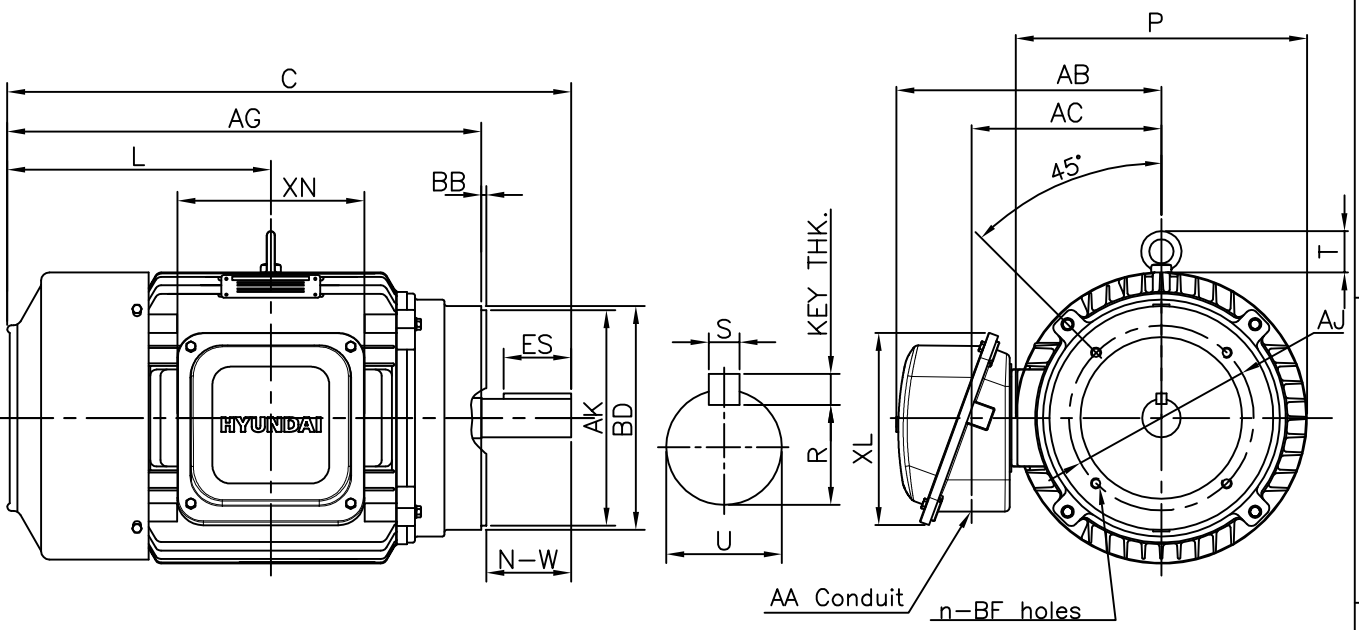

DIMENSIONS

Unit : inch

F L A N G E						CONDUIT BOX					APPROX. WGT.(LB)
AJ	AK	BD	BB	BF	n	AA	AB	AC	XL	XN	
9.00	10.50	10.90	0.25	1/2-13	4	1.50	12.44	9.06	8.43	8.19	410

O V E R A L L							S H A F T			KEY THK.	B E A R I N G	
AG	C	L	P	T	U	N-W	KEYWAY				DRIVE END	OPP. DRIVE END
							R	ES	S			
23.16	27.78	12.91	14.19	2.01	1.875	4.62	1.591	3.28	0.500	0.500	6310ZC3	6310ZC3

**NOTE**

1. Dimension "U" tolerance : +0.000inch - 0.001inch
2. Dimension "R" tolerance : +0.000inch - 0.015inch
3. Dimension "AK" tolerance : +0.000inch - 0.003inch

APPD BY	S.Y.KIM	UNIT	INCH	SUBJECT	NEMA 286TC		DWG SIZE	
CHKD BY	R.G.KIM	SCALE	NONE	TITLE				A4 ( 1:1 )
CHKD BY	Y.H.BAE	PROJEC'N	3각법(3rd Angle)					OUTLINE
DSND BY	H.K.LEE	DATE	2021-04-30	REF. NO	350A8510AA	Sheet No.	of	
				DWG NO	LM-I1286C5PL001	Revision No.	0	



# Cls. I&II, Div. 2 IEEE 841



▽	50S
▽▽	12.5S
▽▽▽	3.2S
▽▽▽▽	0.4S

REV	DATE	CONTENTS	REVD BY	CHKD BY	CHKD BY	APPD BY

일반가공공차		일반제관공차	
1-4	±0.1	6-30	±0.5
4-18	±0.2	30-120	±0.8
18-63	±0.3	120-315	±1.2
63-250	±0.5	315-1000	±2.0
250-	±0.8	1000-	±3.0

Q'TY	DESCRIPTION	MATERIAL	DIMENSION	WEIGHT	PART NO.	REMARK	NO.
APPD BY	S.Y.KIM	UNIT	inch(mm)	SUBJECT	FR. 250-280 (CAST IRON)	DWG SIZE	
CHKD BY		SCALE	1/2	TITLE	TERMINAL BOX ASS'Y		
CHKD BY	R.G.KIM	PROJEC'N	3rd Angle	DATE	2023-10-19		
DSND BY	배승희						
REF. NO		Sheet No.	of				
DWG NO	3M-248458	Revision No.	0				

