

Customer :  
Project Name :  
Project No. :  
Revision No. :

# SPECIFICATION for INDUCTION MOTOR



0		For Bidding			
No.	DATE	DESCRIPTION	PREPARED BY	CHECKED BY	APPROVED BY



# AC INDUCTION MOTOR DATA SHEET

## IEEE841 TYPE

Catalog No.	IEEE3-12-213TCRD	Item No.	Rev. No. [      ]
Project Name		Project No.	Quantity                      sets

GENERAL SPECIFICATION		PERFORMANCE DATA				
Frame Size	213TC	Rated Output	2.2 kW                      3 HP			
Type	PJP	Number of Poles	6			
Enclosure(Protection)	Totally Enclosed / IP55	Rotor Type	Squirrel Cage			
Method of Cooling	IC411(FC)	Starting Method*	D.O.L			
Rated Frequency	60 Hz	Rated Voltage	575 V	460 V	230 V	
Number of Phases	3	Current	Full Load	3.68 A	4.60 A	9.21 A
Insulation Class	F		Locked-rotor**	770 %	770 %	770 %
Temp. Rise at full load (by resistance method)		Efficiency				
at 1.0 S.F	80 deg. C	50% Load		86.5 %		
Motor Location	<input type="checkbox"/> Indoor <input type="checkbox"/> Outdoor	75% Load		88.5 %		
Altitude	Less than 1,000 meter	100% Load		89.5 %		
Relative Humidity	Less than 80 %	Power Factor(p.u)				
Ambient Temp.	40 deg. C (Max.)	50% Load		0.520		
Duty Type	Continuous ( S1 )	75% Load		0.620		
Service Factor	1.15	100% Load		0.670		
Mounting	B5	Speed at Full Load	1185 r.p.m			
Bearing	Type	Anti-Friction				
	DE/N-DE	6208ZC3 / 6208ZC3				
	Lubricant	Grease(Polyrex-EM)				
External Thrust	Not applicable					
Coupling Method	<input checked="" type="checkbox"/> Direct <input type="checkbox"/> V-belt	Torque				
Shaft Extension	Single	Full Load		13.1 lb.ft		
Terminal Box	Main	Locked-rotor**		180 %		
	Aux.	Breakdown**		250 %		
Box Location	Refer to Outline Drawing	Moment of Inertia (J)				
Application		Load(Max.)		55.860 lb.ft2		
Area classification	Hazardous	Motor		0.949 lb.ft2		
Type of Ex-Protection	Class I&II, Division 2	Sound Pressure Level (No-load & mean value at 1m from motor)				
Applicable Standard	IEEE841, NEMA MG1, CSA C390			57 dB(A)		
ACCESSORIES		Vibration				3.8 mm/sec (peak)
		Permissible number of consecutive starts		Cold	3 times	
				Hot	2 times	
		Paint	Munsell No.	7.5BG6/1.5		
SPARE PARTS		SUBMITTAL DRAWING				
		Outline Dimension Drawing		Motor Weight(Approx.)		
		B5	LM-I2213C5PLV23	160 lb.		
REMARK		1. Premium efficiency according to NEMA MG1				
		2. Inverter Duty @ 1.0 Service Factor & F Temperature rise				
		- 10:1 VT (20:1 VT at 50% load)				
		- 10:1 CT				
		- CHP up to 1.5 times base speed, NEMA MG1 Part31				
REMARK		3. CSA Certification				
		- Class I, Division 2, Group A, B, C & D				
		- Class II, Division 2 Group E, F & G (Group E : up to 320Fr.)				
		4. Service Factor 1.15 and Temperature rise B are applicable under the condition of sine wave power.				
		5. Service Factor 1.25 is applicable to motors of 100HP or less with temperature rise F & Non-Hazardous.				
REMARK		Date	DSND	CHKD	CHKD	APPD
		2024-07-13	S.H. Lee	I.K. Kim	R.G. Kim	S.W. Kim

[Note] Others not mentioned in this data sheet shall be in accordance with maker standard.  
 Above technical data are only design values and shall be guaranteed with tolerance of applicable standard.  
 Inspection and performance test shall be done according to maker standard, if not mentioned.  
 \* In case of Inverter-Fed Motor, performance data is based on sine wave tests. It may be different from test data of Inverter combined motor.  
 \*\* Data is based on rated voltage & frequency and is expressed as a percentage of full-load value.

1	2	3	4
REV	DATE	CONTENTS	REVD BY

3.94

**CROWN TRITON G2** Premium Efficiency AC 3 Phase Motor Cat. No. IEE3-12-213TCRD

3HP	6P	460V	Amps	4.6	Type	HLS	Amb.	40°C	
Frame	213TC	Duty	CONT	Encl.	TEFC	Model	HLS213PR338	NEMA Nom. Eff. 89.5%	
RPM	1185	Hertz	60Hz	S.F.	1.15	INS. Class	F HD-F1	3/4 Eff. 88.5%	
Bearing	Drive	6208ZC3	S.F.1.25 (When 100HP or less, Temp Rise F & Non-Hazardous)				NEMA Design	B Torque	
	Opp.	6208ZC3	S.F.1.00 (10:1 C.T., 20:1 V.T., NEMA-MG1 Part31)				Code	L	
Usable at	50Hz 2HP 380V 5.5A 985rpm S.F.: 1.0 Eff.: 79.8% Code: L								
	50Hz 2HP 400/415V 5.9/6.3A 985/985rpm S.F.: 1.0 Eff.: 79.8/79.8% Code: L/L								
CSA Certified for	Model	LATER			Type	PJP	Temp. Code	Frame	140-320FR
	CLASS I, Div. 2, Gr. A, B, C & D		CLASS II, Div. 2, Gr. E, F & G (Gr. E : up to 320FR)			(Sine Wave)	Amb.40°C	T3C (160°C)	
	CLASS I, Zone 2, Gr. IIA, IIB & IIC						Amb.55°C	T3A (180°C)	
No.	-		Date	-		Weight	160 lb		

**MARINE DUTY IEE45**  
IEEE Std 841-2021

1.57

APPD BY	S.Y.KIM	UNIT	INCH	SUBJECT	CSA Class I, Division2 IEE841 (HL)	DWG SIZE
CHKD BY	I.K.KIM	SCALE	NONE			A4 ( 1:1 )
CHKD BY	R.G.KIM	PROJEC'N	3rd Angle	TITLE <b>NAMEPLATE DRAWING</b>		
DSND BY	S.H.LEE	DATE	2024.06.07			



REF. NO	<b>4M-135733</b>	Sheet No.	of
DWG NO	<b>NP-IEE3-12-213TCRD</b>	Revision No.	<b>0</b>

Type :	PJP
Full Load Torque :	13.1 lb.ft
Load moment of Inertia (J) :	55.860 lb.ft2
Motor moment of Inertia (J) :	0.949 lb.ft2

2.2kW	3HP	6 P	60 Hz
Speed at Full Load :			1185 RPM
Rated Voltage	575V	460V	230V
Full Load Current	3.7A	4.6A	9.2A

SPEED VS TORQUE & CURRENT CURVE

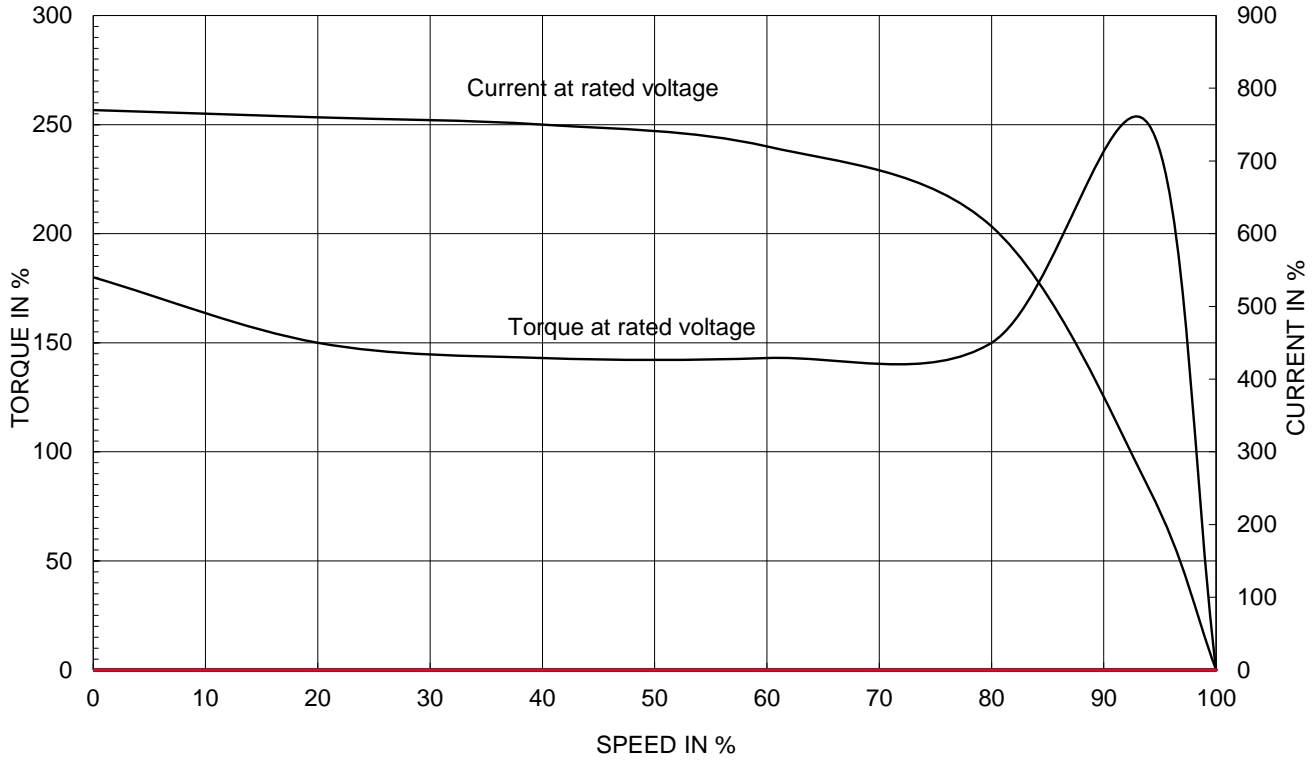

OUTPUT VS EFF., P.F & CURRENT CURVE

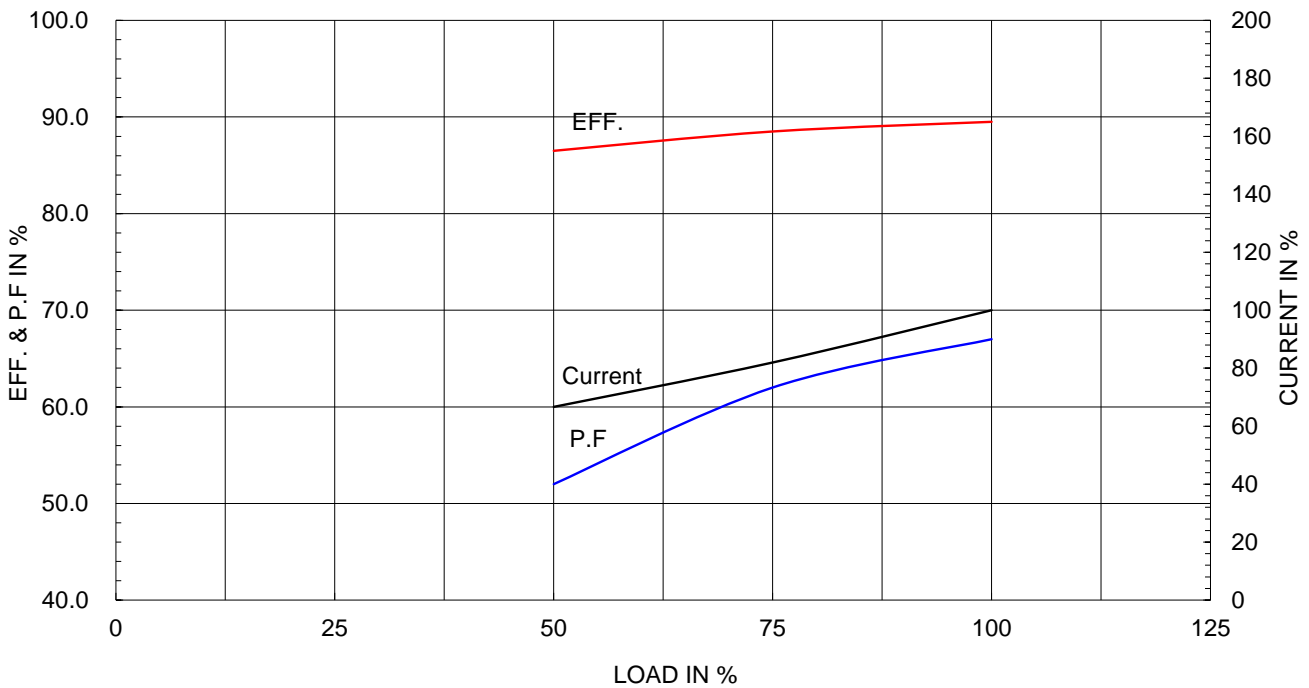

본 도면은 HD현대일렉트릭(주) 재산이며 허가없이 복사할 수 없음 (취급유의)

THIS DRAWING IS PROPRIETARY TO HYUNDAI ELECTRIC. NO PART OF THIS DRAWING MAYBE REPRODUCED WITHOUT THE PERMISSION OF HYUNDAI ELECTRIC.

1		2		3		4			
▽	50S	REV	DATE	CONTENTS		REVD BY	CHKD BY	CHKD BY	APPD BY
▽▽	12.5S								
▽▽▽	3.2S								
▽▽▽▽	0.4S								

## IEEE841

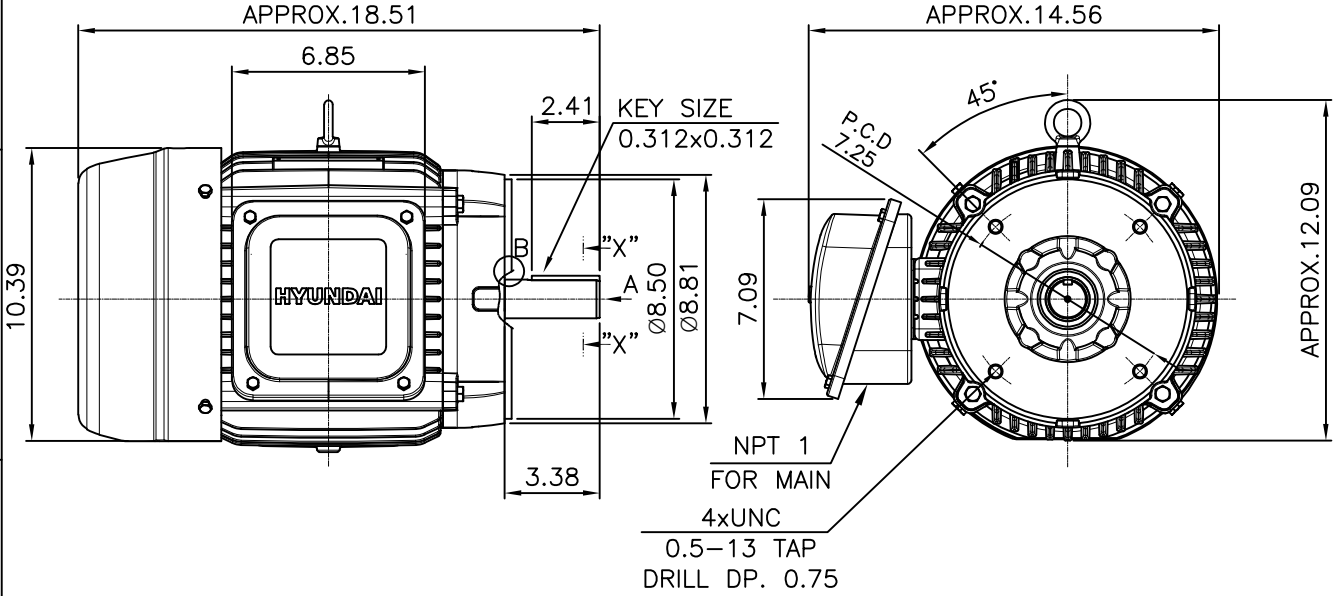

VIEW "A"

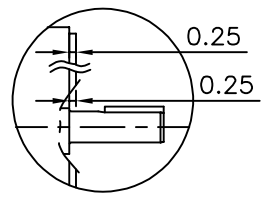

DETAIL - B

### NOTE

[TOLERANCE]

1. CENTER HEIGHT : +0.00inch - 0.03inch
2. SHAFT DIAMETER : +0.000inch - 0.0005inch
3. KEYWAY DEPTH : +0.000inch - 0.015inch

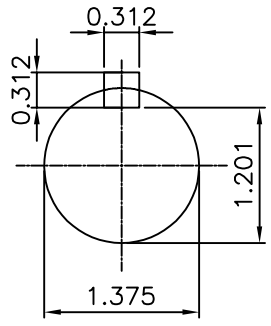

SECTION "X-X"  
SCALE 4/7

APPD BY	S.Y.KIM	UNIT	mm	SUBJECT	NEMA 213TC	DWG SIZE	A4 ( 1:7 )
CHKD BY	R.G.KIM	SCALE	1/7	TITLE	OUTLINE	REF. NO	Sheet No. of
CHKD BY		PROJEC'N	3rd Angle				
DSND BY	J.H.JEON	DATE	2023-01-18				
				DWG NO	LM-I2213C5PLV23	REF. NO	.
						Revision No.	0

**Cls. I&II, Div. 2  
IEEE 841**

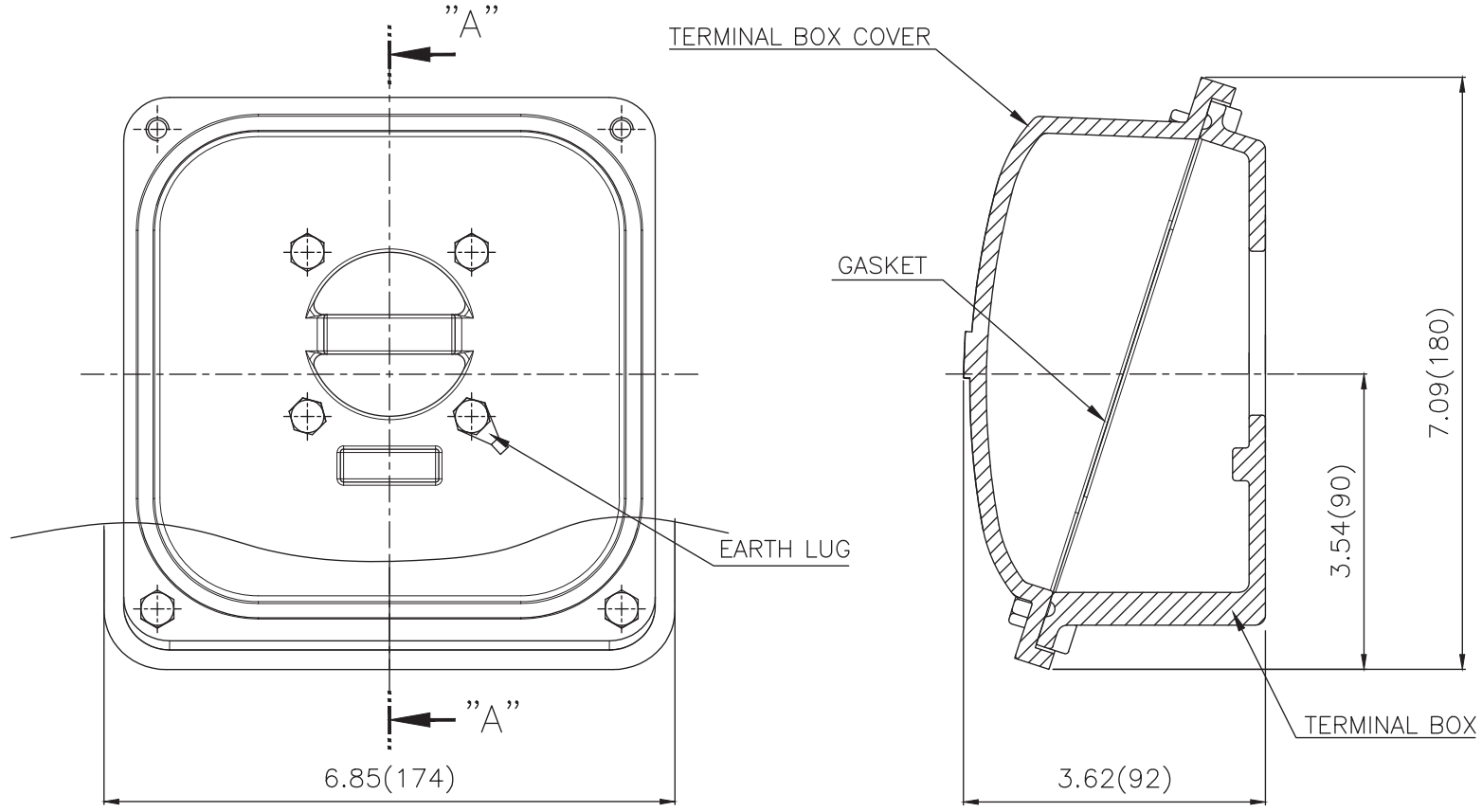

▽	50S
▽▽	12.5S
▽▽▽	3.2S
▽▽▽▽	0.4S

REV	DATE	CONTENTS	REVD BY	CHKD BY	CHKD BY	APPD BY

일반기공공차		일반재관공차	
1-4	±0.1	6-30	±0.5
4-18	±0.2	30-120	±0.8
18-63	±0.3	120-315	±1.2
63-250	±0.5	315-1000	±2.0
250-	±0.8	1000-	±3.0

Q'TY	DESCRIPTION	MATERIAL	DIMENSION	WEIGHT	PART NO.	REMARK	NO.
APPD BY	S.Y.KIM	UNIT	inch(mm)	SUBJECT	FR. 210 (CAST IRON)	DWG SIZE	
CHKD BY		SCALE	1/1.5	TITLE	TERMINAL BOX ASS'Y		
CHKD BY	R.G.KIM	PROJEC'N	3rd Angle	DATE	2023-10-19		
DSND BY	배승희						
REF. NO		Sheet No.	of				
DWG NO	3M-248457	Revision No.	0				

