

Customer :
Project Name :
Project No. :
Revision No. :

SPECIFICATION for INDUCTION MOTOR



0		For Bidding			
No.	DATE	DESCRIPTION	PREPARED BY	CHECKED BY	APPROVED BY



AC INDUCTION MOTOR DATA SHEET

IEEE841 TYPE

Catalog No.	IEEE250-18-449TC	Item No.	Rev. No.	[]
Project Name		Project No.	Quantity	sets

GENERAL SPECIFICATION		PERFORMANCE DATA				
Frame Size	449TC	Rated Output	190 kW 250 HP			
Type	PJP	Number of Poles	4			
Enclosure(Protection)	Totally Enclosed / IP55	Rotor Type	Squirrel Cage			
Method of Cooling	IC411(FC)	Starting Method*	D.O.L			
Rated Frequency	60 Hz	Rated Voltage	575 V	460 V	230 V	
Number of Phases	3	Current	Full Load	225.4 A	281.7 A	
Insulation Class	F		Locked-rotor**	700 %	700 %	700 %
Temp. Rise at full load (by resistance method)		Efficiency				
at 1.0 S.F	80 deg. C	50% Load		93.2 %		
Motor Location	<input type="checkbox"/> Indoor <input type="checkbox"/> Outdoor	75% Load		95.2 %		
Altitude	Less than 1,000 meter	100% Load		96.2 %		
Relative Humidity	Less than 80 %	Power Factor(p.u)				
Ambient Temp.	40 deg. C (Max.)	50% Load		0.730		
Duty Type	Continuous (S1)	75% Load		0.830		
Service Factor	1.15	100% Load		0.880		
Mounting	B35	Speed at Full Load	1785 r.p.m			
Bearing	Type	Anti-Friction				
	DE/N-DE	6318C3 / 6316C3				
	Lubricant	Grease(Polyrex-EM)				
External Thrust	Not applicable					
Coupling Method	<input checked="" type="checkbox"/> Direct <input type="checkbox"/> V-belt	Torque				
Shaft Extension	Single	Full Load		749.9 lb.ft		
Terminal Box	Main	Locked-rotor**		140 %		
	Aux.	Breakdown**		220 %		
Location	Refer to Outline Drawing	Moment of Inertia (J)				
Application		Load(Max.)		3,318.708 lb.ft2		
Area classification	Hazardous	Motor		105.370 lb.ft2		
Type of Ex-Protection	Class I&II, Division 2	Sound Pressure Level (No-load & mean value at 1m from motor)				
Applicable Standard	IEEE841, NEMA MG1, CSA C390			85 dB(A)		
ACCESSORIES		Vibration				3.8 mm/sec (peak)
		Permissible number of consecutive starts		Cold	3 times	
				Hot	2 times	
		Paint	Munsell No.	7.5BG6/1.5		
SPARE PARTS		SUBMITTAL DRAWING				
		Outline Dimension Drawing		Motor Weight(Approx.)		
		B35	LM-I1449C4PL001	2510 lb.		
REMARK		1. Premium efficiency according to NEMA MG1				
		2. Inverter Duty @ 1.0 Service Factor & F Temperature rise				
		- 10:1 VT (20:1 VT at 50% load)				
		- 10:1 CT				
		- CHP up to 1.5 times base speed, NEMA MG1 Part31				
		3. CSA Certification				
		- Class I, Division 2, Group A, B, C & D				
		- Class II, Division 2 Group E, F & G (Group E : up to 320Fr.)				
		4. Service Factor 1.15 and Temperature rise B are applicable under the condition of sine wave power.				
		5. Service Factor 1.25 is applicable to motors of 100HP or less with temperature rise F & Non-Hazardous.				
		Date	DSND	CHKD	CHKD	APPD
		2024-07-13	S.H. Lee	I.K. Kim	R.G. Kim	S.W. Kim

[Note] Others not mentioned in this data sheet shall be in accordance with maker standard.
 Above technical data are only design values and shall be guaranteed with tolerance of applicable standard.
 Inspection and performance test shall be done according to maker standard, if not mentioned.
 * In case of Inverter-Fed Motor, performance data is based on sine wave tests. It may be different from test data of Inverter combined motor.
 ** Data is based on rated voltage & frequency and is expressed as a percentage of full-load value.



PERFORMANCE CURVE

CURVE NO.
PC-IEEE250-18-449TC

Type :	PJP	
Full Load Torque :	749.9	lb.ft
Load moment of Inertia (J) :	3318.708	lb.ft2
Motor moment of Inertia (J) :	105.370	lb.ft2

190kW	250HP	4 P	60 Hz
Speed at Full Load :			1785 RPM
Rated Voltage	575V	460V	230V
Full Load Current	225.4A	281.7A	563.4A

SPEED VS TORQUE & CURRENT CURVE

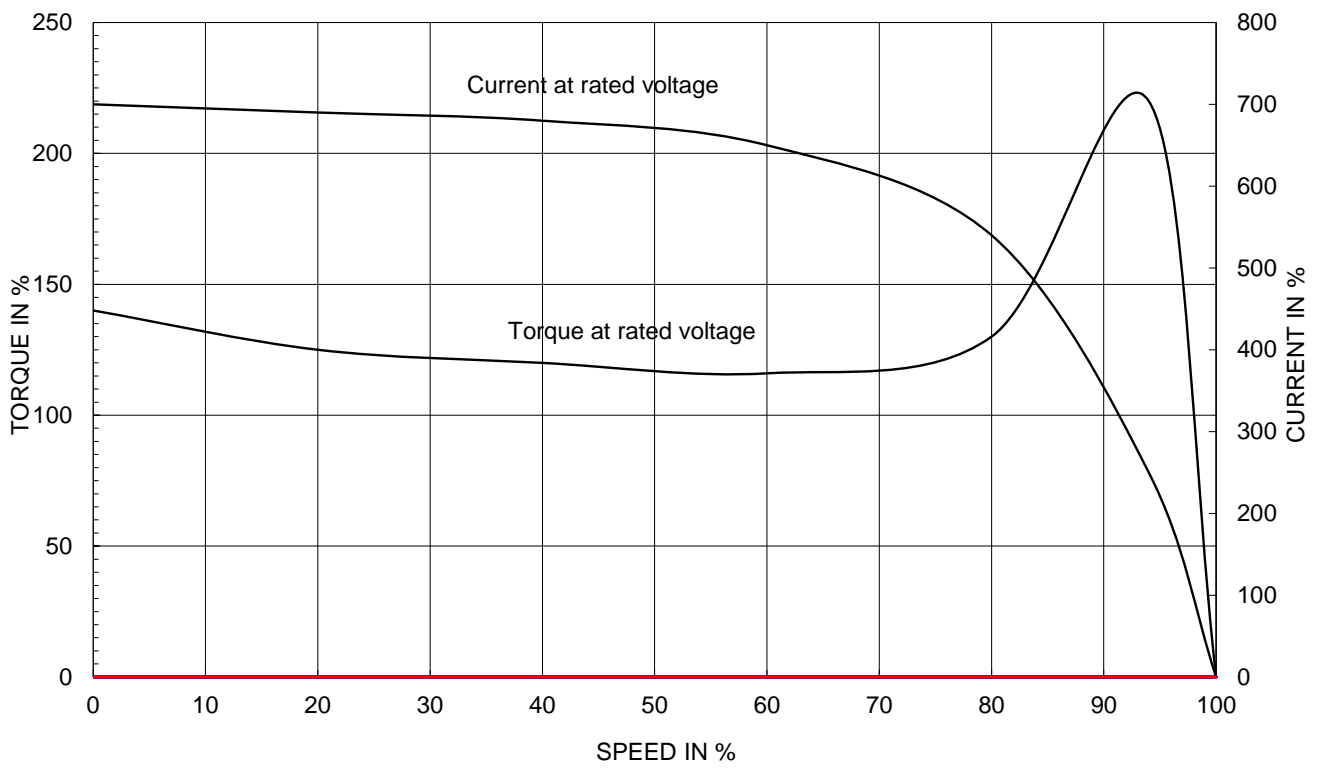

OUTPUT VS EFF., P.F & CURRENT CURVE

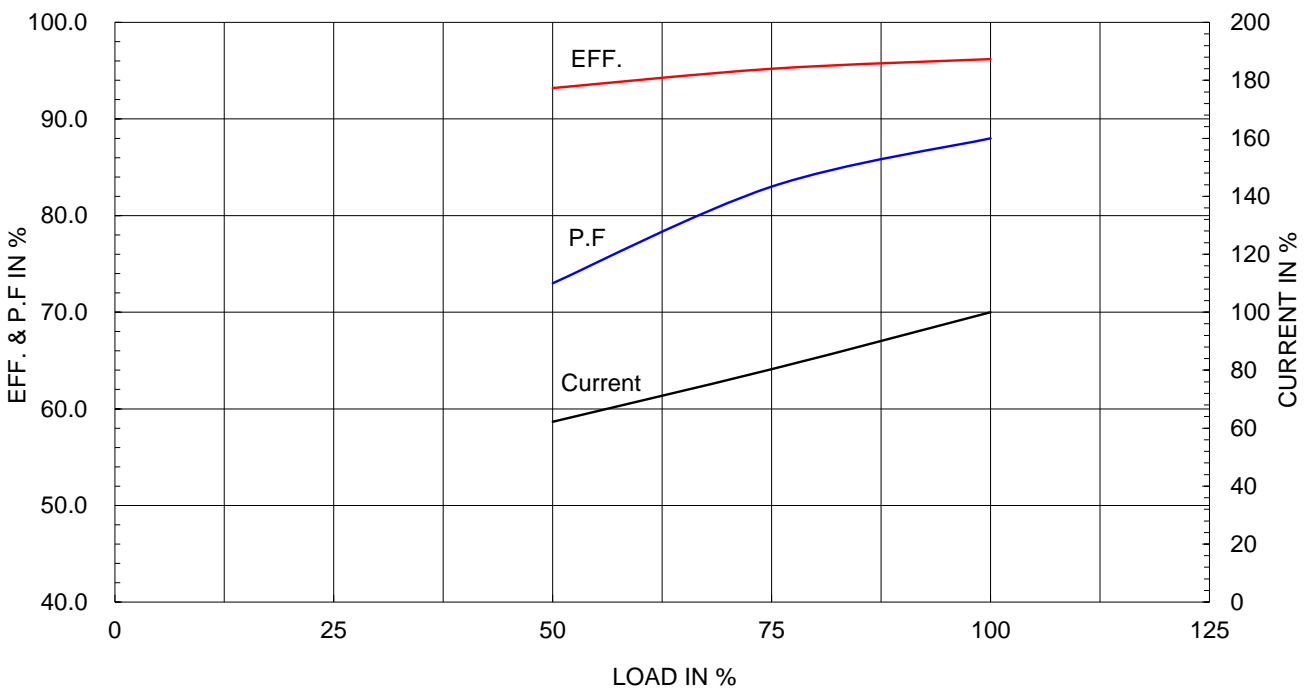

본 도면은 HD현대일렉트릭(주) 재산이며 허가없이 복사할 수 없음 (취급주의)

THIS DRAWING IS PROPRIETARY TO HYUNDAI ELECTRIC. NO PART OF THIS DRAWING MAYBE REPRODUCED WITHOUT THE PERMISSION OF HYUNDAI ELECTRIC.

1	2	3	4
▽	50S	REV	DATE
▽▽	12.5S		
▽▽▽	3.2S		
▽▽▽▽	0.4S		

IEEE841

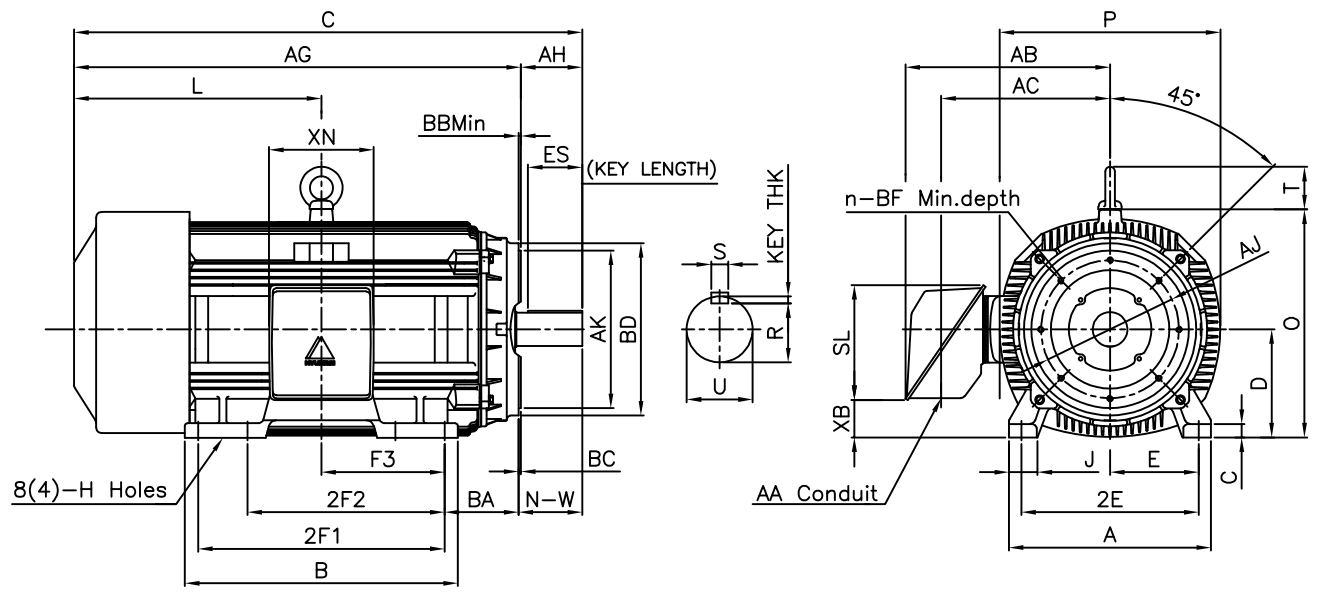

DIMENSIONS

Unit : inch

M O U N T I N G									C O N D U I T B O X					APPROX. WGT.(LB)	
A	B	2E	2F1	2F2	F3	G	J	H	AA	AB	AC	XB	XL		XN
20.51	27.72	18.00	25.00	(20.00)	12.500	1.42	3.07	0.81	3.00	23.78	18.03	3.14	16.30	13.78	2510

O V E R A L L									S H A F T			KEY	BEARING		
BA	C	D	L	O	P	T	AG	U	N-W	KEYWAY			THK.	DRIVE END	OPP. DRIVE END
										R	ES	S			
7.50	53.83	11.00	26.92	23.19	22.44	4.33	45.33	3.375	8.50	2.880	6.93	0.875	0.875	6318C3	6316C3

C - F A C E								
AJ	AK	BB Min	BC	BD	BF	BF depth	n	AH
14.00	16.00	0.25	0.25	17.48	5/8-11	0.94	8	8.25

NOTE

- 1.Dimension "D" tolerance : +0.00inch ~ -0.03inch (143TC-365TC) : +0.000inch ~ -0.06inch (404TC-449TC)
- 2.Dimension "U" tolerance : +0.000inch ~ -0.0005inch (143TC-215TC): +0.000inch ~ -0.001inch (254TC-449TC)
- 3.Dimension "R" tolerance : +0.000inch ~ - 0.015inch
- 4.Dimension "AK" tolerance : +0.000inch ~ -0.003inch (143TC-286TC): +0.000inch ~ -0.005inch (324TC-449TC)

APPD BY	S.Y.KIM	UNIT	INCH	SUBJECT	NEMA 449TC	DWG SIZE	A4 (1:1)
CHKD BY	R.G.KIM	SCALE	NONE				
CHKD BY	Y.H.BAE	PROJEC'N	3각법(3rd Angle)	TITLE OUTLINE			
DSND BY	H.K.LEE	DATE	2021-05-06				
				REF. NO	350A8320AA	Sheet No.	of
				DWG NO	LM-11449C4PL001	Revision No.	0

Cls. I&II, Div. 2 IEEE 841

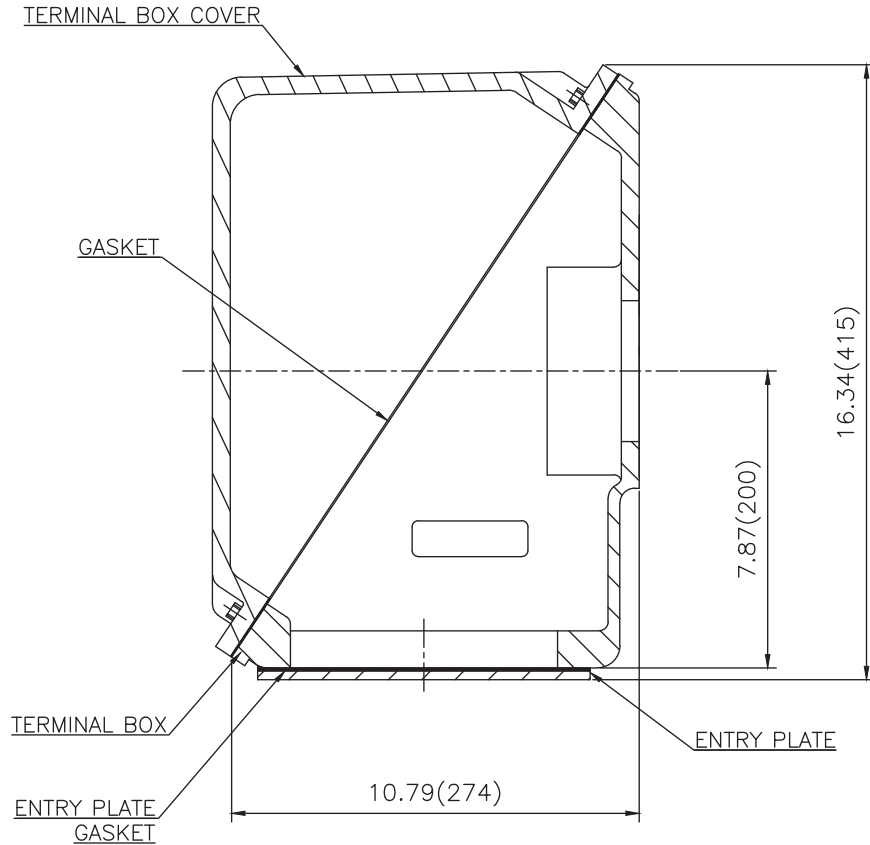
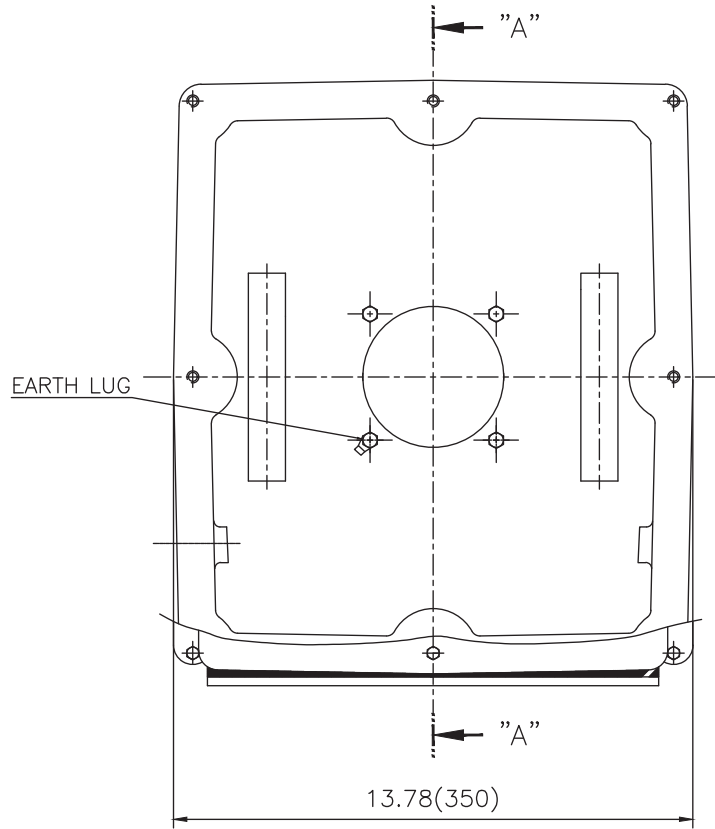

SEC. "A"-"A"

▽	50S
▽▽	12.5S
▽▽▽	3.2S
▽▽▽▽	0.4S

REV	DATE	CONTENTS	REVD BY	CHKD BY	CHKD BY	APPD BY

일반가공공차		일반제관공차	
1-4	±0.1	6-30	±0.5
4-18	±0.2	30-120	±0.8
18-63	±0.3	120-315	±1.2
63-250	±0.5	315-1000	±2.0
250-	±0.8	1000-	±3.0

Q'TY	DESCRIPTION	MATERIAL	DIMENSION	WEIGHT	PART NO.	REMARK	NO.
APPD BY	S.Y.KIM	UNIT	inch(mm)	SUBJECT	FR. L440 (CAST IRON)	DWG SIZE	A3 (1:3.5)
CHKD BY		SCALE	1/3.5	TITLE			
CHKD BY	R.G.KIM	PROJEC'N	3rd Angle	MAIN TERMINAL BOX ASS'Y			
DSND BY	배승희	DATE	2023-10-19	REF. NO		Sheet No.	of
HD HYUNDAI ELECTRIC				DWG NO	3M-248452	Revision No.	0

