

Customer :  
Project Name :  
Project No. :  
Revision No. :

# SPECIFICATION for INDUCTION MOTOR



0		For Bidding			
No.	DATE	DESCRIPTION	PREPARED BY	CHECKED BY	APPROVED BY



# AC INDUCTION MOTOR DATA SHEET

## IEEE841 TYPE

Catalog No.	IEEE200-36-447TSCRD	Item No.	Rev. No. [      ]
Project Name		Project No.	Quantity                      sets

GENERAL SPECIFICATION		PERFORMANCE DATA				
Frame Size	447TSC	Rated Output	150 kW                      200 HP			
Type	PJP	Number of Poles	2			
Enclosure(Protection)	Totally Enclosed / IP55	Rotor Type	Squirrel Cage			
Method of Cooling	IC411(FC)	Starting Method*	D.O.L			
Rated Frequency	60 Hz	Rated Voltage	575 V	460 V	230 V	
Number of Phases	3	Current	Full Load	175.4 A	219.3 A	438.5 A
Insulation Class	F		Locked-rotor**	700 %	700 %	700 %
Temp. Rise at full load (by resistance method)		Efficiency				
at 1.0 S.F	80 deg. C	50% Load		92.4 %		
Motor Location	<input type="checkbox"/> Indoor <input type="checkbox"/> Outdoor	75% Load		94.4 %		
Altitude	Less than 1,000 meter	100% Load		95.4 %		
Relative Humidity	Less than 80 %	Power Factor(p.u)				
Ambient Temp.	40 deg. C (Max.)	50% Load		0.750		
Duty Type	Continuous ( S1 )	75% Load		0.850		
Service Factor	1.15	100% Load		0.900		
Mounting	B5	Speed at Full Load	3570 r.p.m			
Bearing	Type	Anti-Friction				
	DE/N-DE	6314C3 / 6314C3				
	Lubricant	Grease(Polyrex-EM)				
External Thrust	Not applicable					
Coupling Method	<input checked="" type="checkbox"/> Direct <input type="checkbox"/> V-belt	Torque				
Shaft Extension	Single	Full Load		296.0 lb.ft		
Terminal Box	Main	Locked-rotor**		120 %		
	Aux.	Breakdown**		220 %		
Box Location	Refer to Outline Drawing	Moment of Inertia (J)				
Application		Load(Max.)		341.126 lb.ft2		
Area classification	Hazardous	Motor		44.130 lb.ft2		
Type of Ex-Protection	Class I&II, Division 2	Sound Pressure Level (No-load & mean value at 1m from motor)				
Applicable Standard	IEEE841, NEMA MG1, CSA C390	85 dB(A)				
ACCESSORIES		Vibration				3.8 mm/sec (peak)
		Permissible number of consecutive starts		Cold	3 times	
				Hot	2 times	
		Paint	Munsell No.	7.5BG6/1.5		
SPARE PARTS		SUBMITTAL DRAWING				
		Outline Dimension Drawing		Motor Weight(Approx.)		
		B5	LM-I1447C5CL003	2060 lb.		
REMARK		<ol style="list-style-type: none"> <li>1. Premium efficiency according to NEMA MG1</li> <li>2. Inverter Duty @ 1.0 Service Factor &amp; F Temperature rise <ul style="list-style-type: none"> <li>- 10:1 VT (20:1 VT at 50% load)</li> <li>- 10:1 CT</li> <li>- CHP up to 1.5 times base speed, NEMA MG1 Part31</li> </ul> </li> <li>3. CSA Certification <ul style="list-style-type: none"> <li>- Class I, Division 2, Group A, B, C &amp; D</li> <li>- Class II, Division 2 Group E, F &amp; G (Group E : up to 320Fr.)</li> </ul> </li> <li>4. Service Factor 1.15 and Temperature rise B are applicable under the condition of sine wave power.</li> <li>5. Service Factor 1.25 is applicable to motors of 100HP or less with temperature rise F &amp; Non-Hazardous.</li> </ol>				
		Date	DSND	CHKD	CHKD	APPD
		2024-07-13	S.H. Lee	I.K. Kim	R.G. Kim	S.W. Kim

[Note] Others not mentioned in this data sheet shall be in accordance with maker standard.  
 Above technical data are only design values and shall be guaranteed with tolerance of applicable standard.  
 Inspection and performance test shall be done according to maker standard, if not mentioned.  
 \* In case of Inverter-Fed Motor, performance data is based on sine wave tests. It may be different from test data of Inverter combined motor.  
 \*\* Data is based on rated voltage & frequency and is expressed as a percentage of full-load value.

1	2	3	4
REV	DATE	CONTENTS	REVD BY   CHKD BY   CHKD BY   APPD BY

4.72



**CROWN TRITON**  
Premium Efficiency AC 3 Phase Motor

200HP	2P	460V	Cat. No.	IEEE200-36-447TSCRD				
Model	HLS447PR02		INS. Class	F	HD-F1	Amps	219.3	
Type	HLS	Duty	CONT	Code	G	Amb.	40°C	
Frame	447TSC	Encl.	TEFC	S.F.	1.15	RPM	3570	
Bearing	Drive	6314C3		S.F.1.00 (10:1 C.T., 20:1 V.T., NEMA-MG1 Part31)		3/4 Eff.	94.4%	
	Opp.	6314C3				NEMA Design	B	
Usable at	50Hz 200HP 380V 267.2A 2962rpm S.F.: 1.0 Eff.: 95.1% Code: E							
	50Hz 200HP 400/415V 253/243.9A 2966/2969rpm S.F.: 1.0 Eff.: 95.3/95.4% Code: F/G							
CSA Certified for	Model	LATER		Type	PJP			
	CLASS I, Div. 2, Gr. A, B, C & D CLASS I, Zone 2, Gr. IIA, IIB, & IIC	CLASS II, Div. 2, Gr. E, F & G (Gr. E : Up to 320FR)		Temp. Code (sine wave)	Frame	140~320FR	360~400FR	440FR
		Amb. 40°C	T3C (160°C)		T3B (165°C)	T3A (180°C)		
Amb. 55°C	T3A (180°C)	T3A (180°C)	T3 (200°C)					
No.	-		Date	-		Weight	2060 lb	

**IEEE Std 841-2021**    **MARINE DUTY IEEE45**

4M-135701                      Made in Korea H1



2.36

APPD BY	S.Y.KIM	UNIT	INCH	SUBJECT	CSA Class I, Division2 IEEE841 (HL)	DWG SIZE	A4 ( 1:1 )
CHKD BY	I.K.KIM	SCALE	NONE				
CHKD BY	R.G.KIM	PROJEC'N	3rd Angle	TITLE <b>NAMEPLATE DRAWING</b>			
DSND BY	S.H.LEE	DATE	2024.06.07				
				REF. NO	<b>4M-135701</b>	Sheet No. of	
				DWG NO	<b>NP-IEEE200-36-447TSCRD</b>	Revision No. <b>0</b>	



# PERFORMANCE CURVE

CURVE NO.  
PC-IEEE200-36-447TSCRD

Type :	PJP
Full Load Torque :	296.0 lb.ft
Load moment of Inertia (J) :	341.126 lb.ft2
Motor moment of Inertia (J) :	44.130 lb.ft2

150kW	200HP	2 P	60 Hz
Speed at Full Load :			3570 RPM
Rated Voltage	575V	460V	230V
Full Load Current	175.4A	219.3A	438.5A

SPEED VS TORQUE & CURRENT CURVE

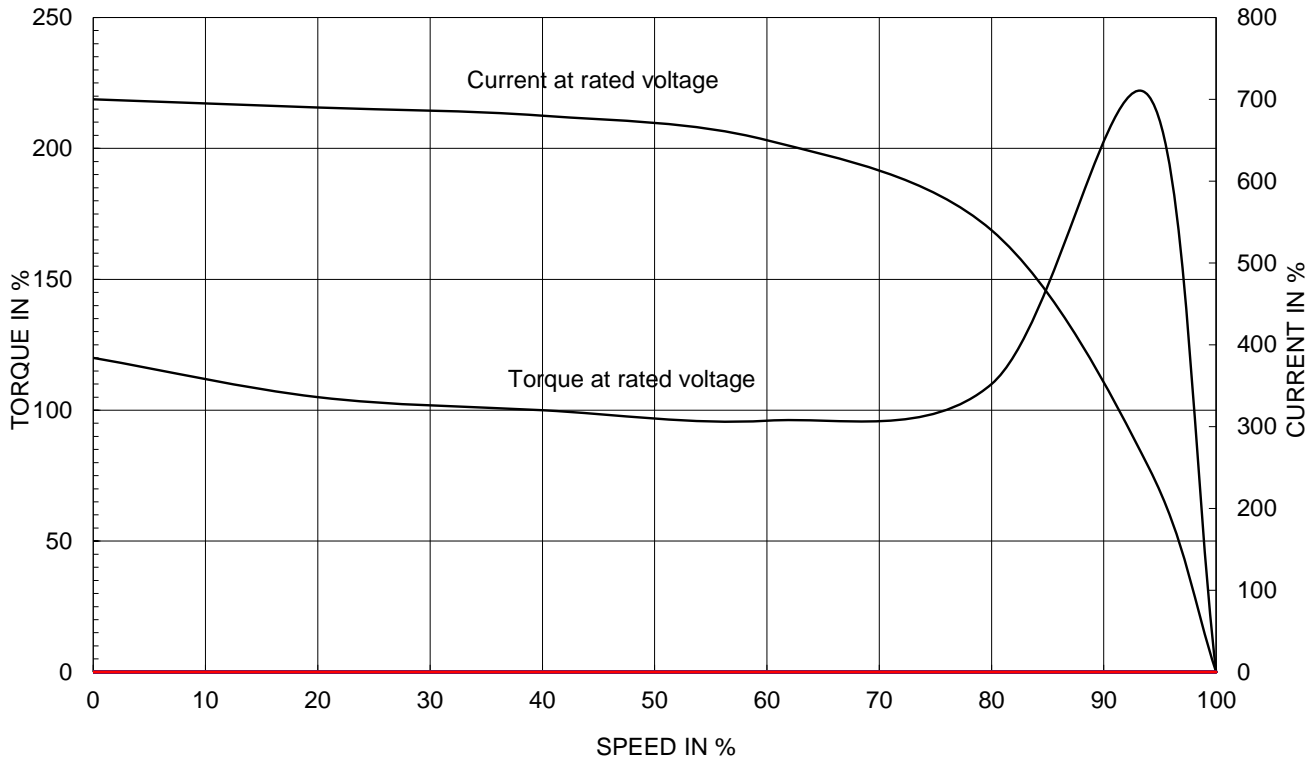

OUTPUT VS EFF., P.F & CURRENT CURVE

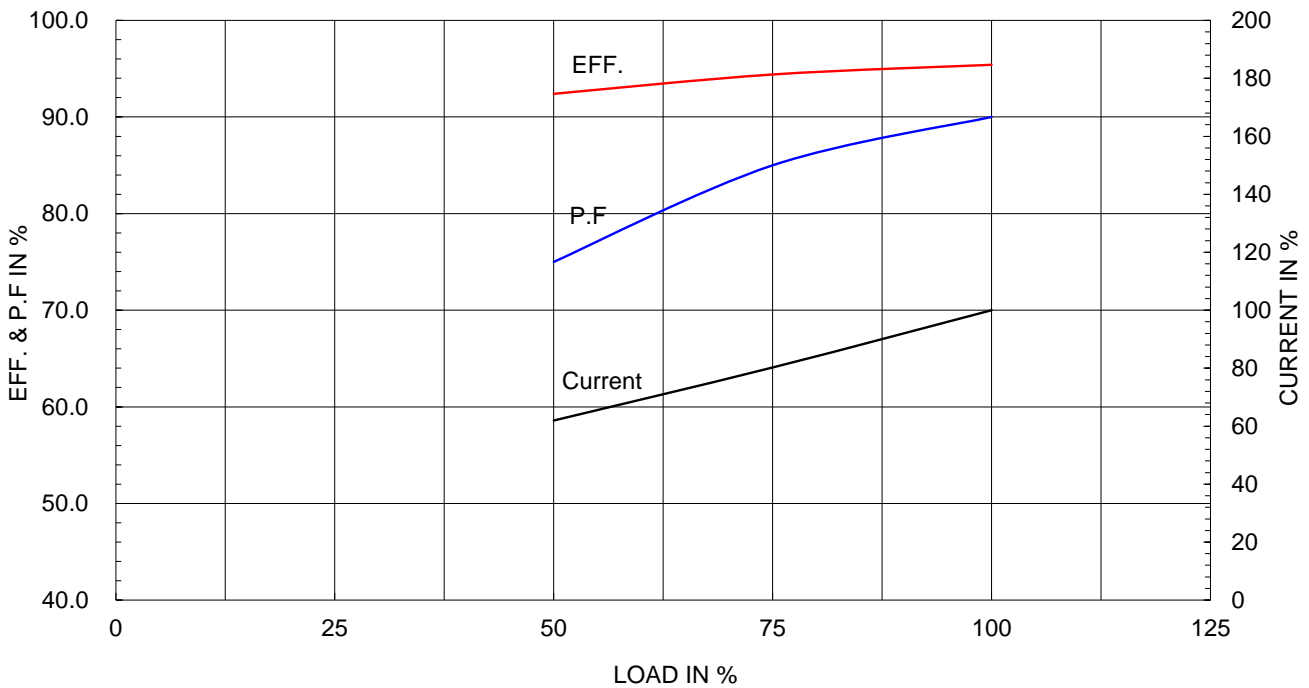

본 도면은 HD현대일렉트릭(주) 재산이며 허가없이 복사할 수 없음 (취급주의)

THIS DRAWING IS PROPRIETARY TO HYUNDAI ELECTRIC. NO PART OF THIS DRAWING MAY BE REPRODUCED WITHOUT THE PERMISSION OF HYUNDAI ELECTRIC.

▽	50S	REV	DATE	CONTENTS	REVD BY	CHKD BY	CHKD BY	APPD BY
▽▽	12.5S							
▽▽▽	3.2S							
▽▽▽▽	0.4S							

**IEEE841**

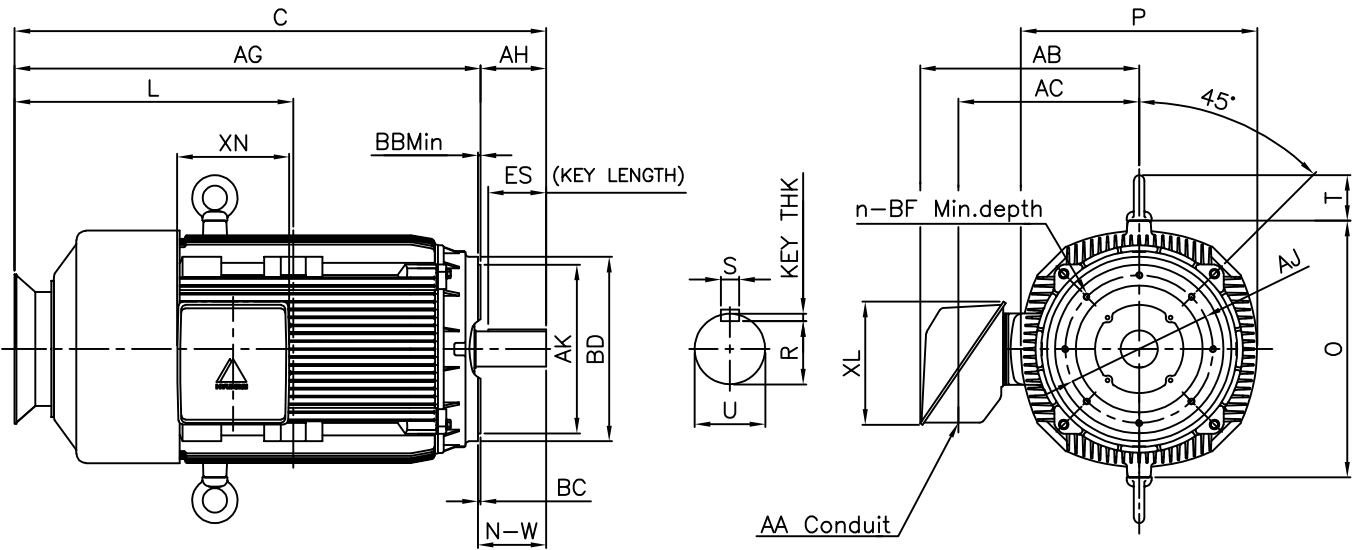

DIMENSIONS

Unit : inch

C - F L A N G E									CONDUIT BOX					APPROX. WGT.(LB)
AJ	AK	BB Min	BC	BD	BF	BF depth	n	AH	AA	AB	AC	XL	XN	
14.00	16.00	0.25	0.25	17.48	5/8-11	0.94	8	4.50	3.00	23.78	18.03	16.30	13.78	2060

O V E R A L L						S H A F T					KEY	BEARING	
C	L	O	P	T	AG	U	N-W	KEYWAY			THK.	DRIVE END	OPP. DRIVE END
								R	ES	S			
50.65	28.43	24.33	22.44	4.33	46.15	2.375	4.75	2.021	3.03	0.625	0.625	6314C3	6314C3

**NOTE**

- 1.Dimension "U" tolerance : +0.000inch ~ -0.0005inch (143TC-215TC): +0.000inch ~ -0.001inch (254TC-449TC)
- 2.Dimension "R" tolerance : +0.000inch ~ - 0.015inch
- 3.Dimension "AK" tolerance : +0.000inch ~ -0.003inch (143TC-286TC): +0.000inch ~ -0.005inch (324TC-449TC)

APPD BY	S.Y.KIM	UNIT	INCH	SUBJECT	NEMA 447TSC	DWG SIZE	A4 ( 1:1 )				
CHKD BY	R.G.KIM	SCALE	NONE	TITLE	OUTLINE	REF. NO	350A8519BA				
CHKD BY	Y.H.BAE	PROJEC'N	3각법(3rd Angle)					DWG NO	LM-I1447C5CL003	Sheet No.	of
DSND BY	H.K.LEE	DATE	2021-04-30							Revision No.	0



REF. NO	350A8519BA	Sheet No.	of
DWG NO	LM-I1447C5CL003	Revision No.	0

# Cls. I&II, Div. 2 IEEE 841

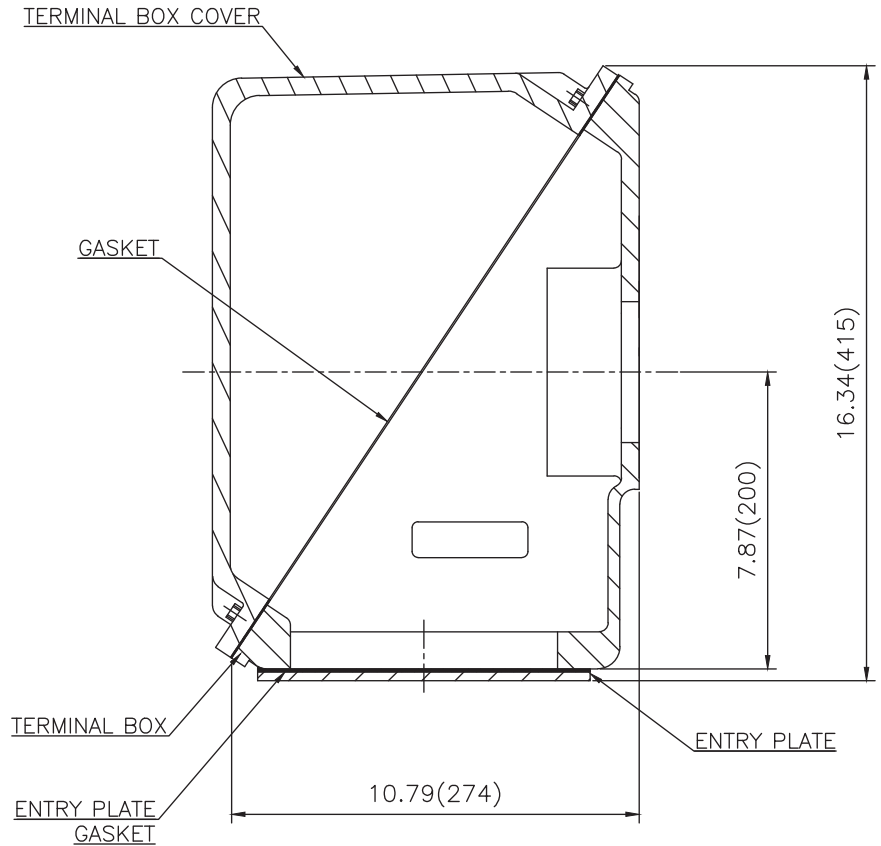
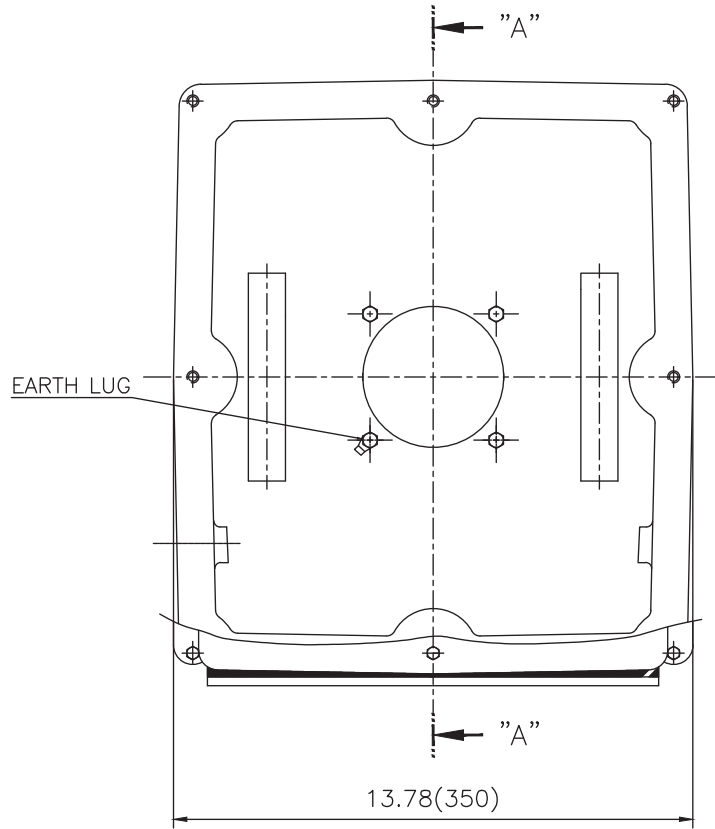

SEC. "A" - "A"

▽	50S
▽▽	12.5S
▽▽▽	3.2S
▽▽▽▽	0.4S

REV	DATE	CONTENTS	REVD BY	CHKD BY	CHKD BY	APPD BY

일반가공공차		일반제관공차	
1-4	±0.1	6-30	±0.5
4-18	±0.2	30-120	±0.8
18-63	±0.3	120-315	±1.2
63-250	±0.5	315-1000	±2.0
250-	±0.8	1000-	±3.0

Q'TY	DESCRIPTION	MATERIAL	DIMENSION	WEIGHT	PART NO.	REMARK	NO.
APPD BY	S.Y.KIM	UNIT	inch(mm)	SUBJECT	FR. L440 (CAST IRON)	DWG SIZE	A3 (1:3.5)
CHKD BY		SCALE	1/3.5	TITLE			
CHKD BY	R.G.KIM	PROJEC'N	3rd Angle	MAIN TERMINAL BOX ASS'Y			
DSND BY	배승희	DATE	2023-10-19	REF. NO		Sheet No.	of
				DWG NO	3M-248452	Revision No.	0

