

Customer :
Project Name :
Project No. :
Revision No. :

SPECIFICATION for INDUCTION MOTOR



0		For Bidding			
No.	DATE	DESCRIPTION	PREPARED BY	CHECKED BY	APPROVED BY



AC INDUCTION MOTOR DATA SHEET

IEEE841 TYPE

Catalog No.	IEEE20-36-256TCRD	Item No.	Rev. No.	[]
Project Name		Project No.	Quantity	sets

GENERAL SPECIFICATION			PERFORMANCE DATA			
Frame Size	256TC	Rated Output	15 kW		20 HP	
Type	PJP	Number of Poles	2			
Enclosure(Protection)	Totally Enclosed / IP55	Rotor Type	Squirrel Cage			
Method of Cooling	IC411(FC)	Starting Method*	D.O.L			
Rated Frequency	60 Hz	Rated Voltage	575 V	460 V	230 V	
Number of Phases	3	Current	Full Load	18.6 A	23.2 A	46.5 A
Insulation Class	F		Locked-rotor**	740 %	740 %	740 %
Temp. Rise at full load (by resistance method)		Efficiency				
at 1.0 S.F	80 deg. C	50% Load		88.0 %		
Motor Location	<input type="checkbox"/> Indoor <input type="checkbox"/> Outdoor	75% Load		90.0 %		
Altitude	Less than 1,000 meter	100% Load		91.0 %		
Relative Humidity	Less than 80 %	Power Factor(p.u)				
Ambient Temp.	40 deg. C (Max.)	50% Load		0.740		
Duty Type	Continuous (S1)	75% Load		0.840		
Service Factor	1.15	100% Load		0.890		
Mounting	B5	Speed at Full Load	3550 r.p.m			
Bearing	Type	Anti-Friction	Torque			
	DE/N-DE	6309ZC3 / 6309ZC3	Full Load	29.8 lb.ft		
	Lubricant	Grease(Polyrex-EM)	Locked-rotor**	150 %		
External Thrust	Not applicable	Breakdown**	250 %			
Coupling Method	<input checked="" type="checkbox"/> Direct <input type="checkbox"/> V-belt	Moment of Inertia (J)				
Shaft Extension	Single	Load(Max.)	21.594 lb.ft2			
Terminal Box	Main	Cast Iron	Motor	1.163 lb.ft2		
	Aux.	No	Sound Pressure Level (No-load & mean value at 1m from motor)			
	Location	Refer to Outline Drawing	79 dB(A)			
Application		Vibration	3.8 mm/sec (peak)			
Area classification	Hazardous	Permissible number of consecutive starts	Cold	3 times		
Type of Ex-Protection	Class I&II, Division 2		Hot	2 times		
Applicable Standard	IEEE841, NEMA MG1, CSA C390	Paint	Munsell No.	7.5BG6/1.5		

ACCESSORIES

SUBMITTAL DRAWING		
Outline Dimension Drawing	Motor Weight(Approx.)	
B5	LM-I1256C5PL001	300 lb.

REMARK

1. Premium efficiency according to NEMA MG1
2. Inverter Duty @ 1.0 Service Factor & F Temperature rise
 - 10:1 VT (20:1 VT at 50% load)
 - 10:1 CT
 - CHP up to 1.5 times base speed, NEMA MG1 Part31
3. CSA Certification
 - Class I, Division 2, Group A, B, C & D
 - Class II, Division 2 Group E, F & G (Group E : up to 320Fr.)
4. Service Factor 1.15 and Temperature rise B are applicable under the condition of sine wave power.
5. Service Factor 1.25 is applicable to motors of 100HP or less with temperature rise F & Non-Hazardous.

Date	DSND	CHKD	CHKD	APPD
2024-07-13	S.H. Lee	I.K. Kim	R.G. Kim	S.W. Kim

[Note] Others not mentioned in this data sheet shall be in accordance with maker standard.
 Above technical data are only design values and shall be guaranteed with tolerance of applicable standard.
 Inspection and performance test shall be done according to maker standard, if not mentioned.
 * In case of Inverter-Fed Motor, performance data is based on sine wave tests. It may be different from test data of Inverter combined motor.
 ** Data is based on rated voltage & frequency and is expressed as a percentage of full-load value.

1	2	3	4
REV	DATE	CONTENTS	REVD BY CHKD BY CHKD BY APPD BY

4.72

CROWN TRITON
Premium Efficiency AC 3 Phase Motor

20HP	2P	460V	Cat. No.	IEEE20-36-256TCRD				
Model	HLS256PR13		INS. Class	F	HD-F1	Amps	23.2	
Type	HLS	Duty	CONT	Code	H	Amb.	40°C	
Frame	256TC	Encl.	TEFC	S.F.	1.15	RPM	3550	
Bearing	Drive	6309ZC3		S.F.1.00 (10:1 C.T., 20:1 V.T., NEMA-MG1 Part31)		3/4 Eff.	90%	
	Opp.	6309ZC3				NEMA Design	B Torque	
Usable at	50Hz 15HP 380V 23.5A 2955rpm S.F.: 1.0 Eff.: 89.4% Code: J							
	50Hz 15HP 400/415V 22.7/22.4A 2960/2960rpm S.F.: 1.0 Eff.: 89.4/89.4% Code: K/L							
CSA Certified for	Model	LATER		Type	PJP			
	CLASS I, Div. 2, Gr. A, B, C & D CLASS I, Zone 2, Gr. IIA, IIB, & IIC	CLASS II, Div. 2, Gr. E, F & G (Gr. E : Up to 320FR)		Temp. Code (sine wave)	Frame	140~320FR	360~400FR	440FR
		Amb. 40°C	T3C (160°C)		T3B (165°C)	T3A (180°C)		
Amb. 55°C	T3A (180°C)	T3A (180°C)	T3 (200°C)					
No.	-		Date	-		Weight	300 lb	

IEEE Std 841-2021 **MARINE DUTY IEEE45**

4M-135701 Made in Korea H1

2.36

APPD BY	S.Y.KIM	UNIT	INCH	SUBJECT	CSA Class I, Division2 IEEE841 (HL)	DWG SIZE	A4 (1:1)
CHKD BY	I.K.KIM	SCALE	NONE				
CHKD BY	R.G.KIM	PROJEC'N	3rd Angle	TITLE NAMEPLATE DRAWING			
DSND BY	S.H.LEE	DATE	2024.06.07				
				REF. NO	4M-135701	Sheet No. of	
				DWG NO	NP-IEEE20-36-256TCRD	Revision No. 0	



PERFORMANCE CURVE

CURVE NO.
PC-IEEE20-36-256TCRD

Type :	PJP
Full Load Torque :	29.8 lb.ft
Load moment of Inertia (J) :	21.594 lb.ft2
Motor moment of Inertia (J) :	1.163 lb.ft2

15kW	20HP	2 P	60 Hz
Speed at Full Load :			3550 RPM
Rated Voltage	575V	460V	230V
Full Load Current	18.6A	23.2A	46.5A

SPEED VS TORQUE & CURRENT CURVE

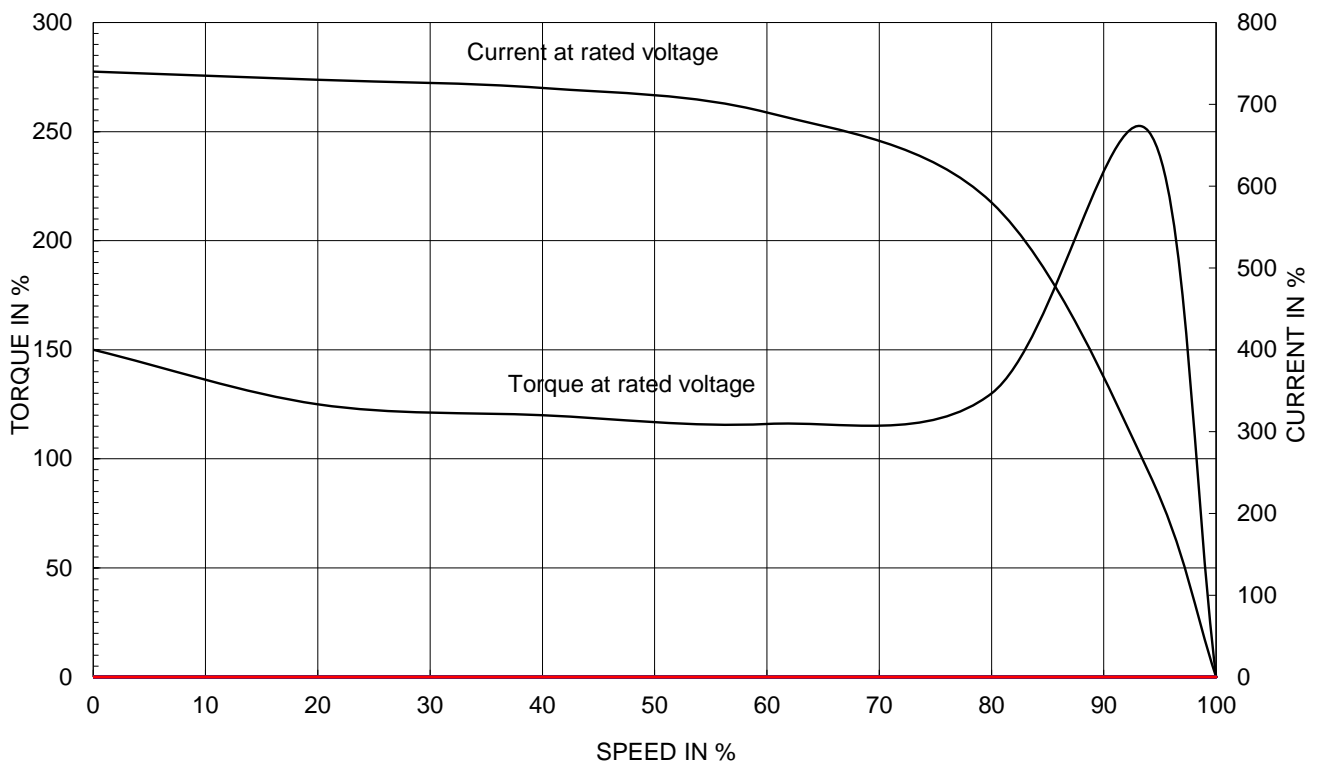

OUTPUT VS EFF., P.F & CURRENT CURVE

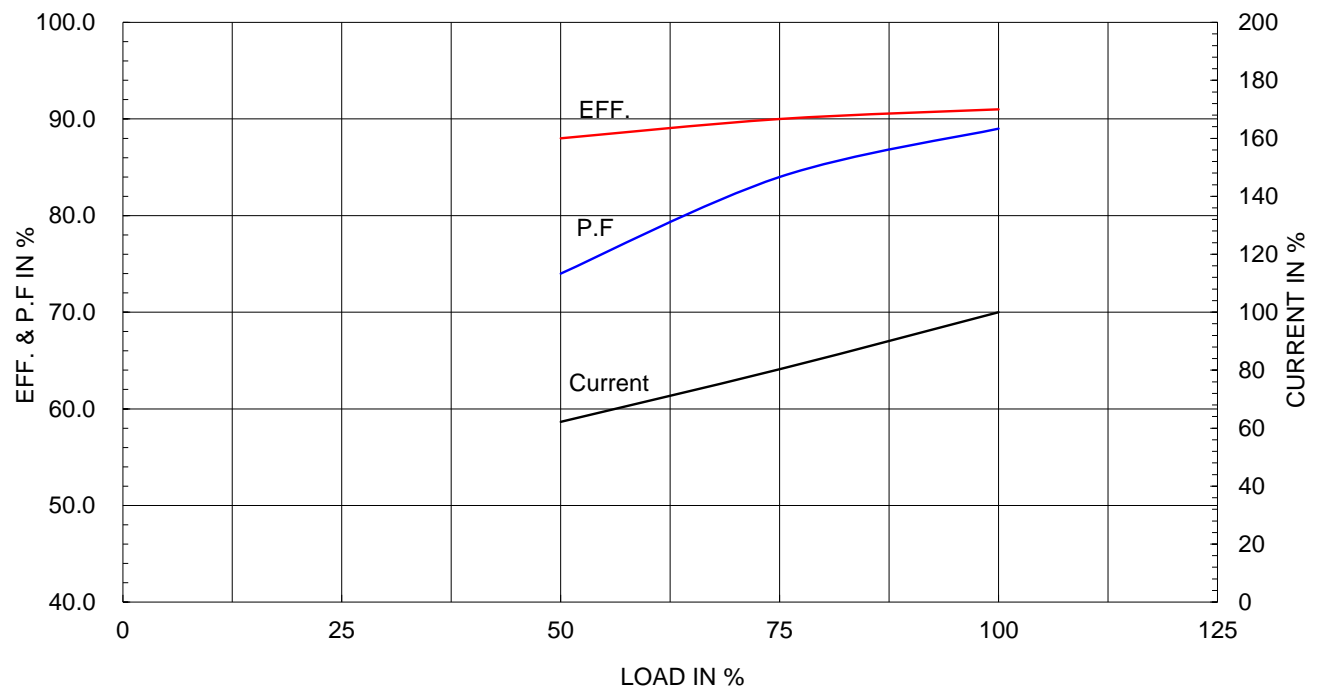

본 도면은 HD현대일렉트릭(주) 재산이며
허가없이 복사할 수 없음 (취급유의)

THIS DRAWING IS PROPRIETARY TO HYUNDAI ELECTRIC. NO PART OF THIS DRAWING
MAYBE REPRODUCED WITHOUT THE PERMISSION OF HYUNDAI ELECTRIC.

▽	50S	REV	DATE	CONTENTS	REVD BY	CHKD BY	CHKD BY	APPD BY
▽▽	12.5S							
▽▽▽	3.2S							
▽▽▽▽	0.4S							

IEEE841

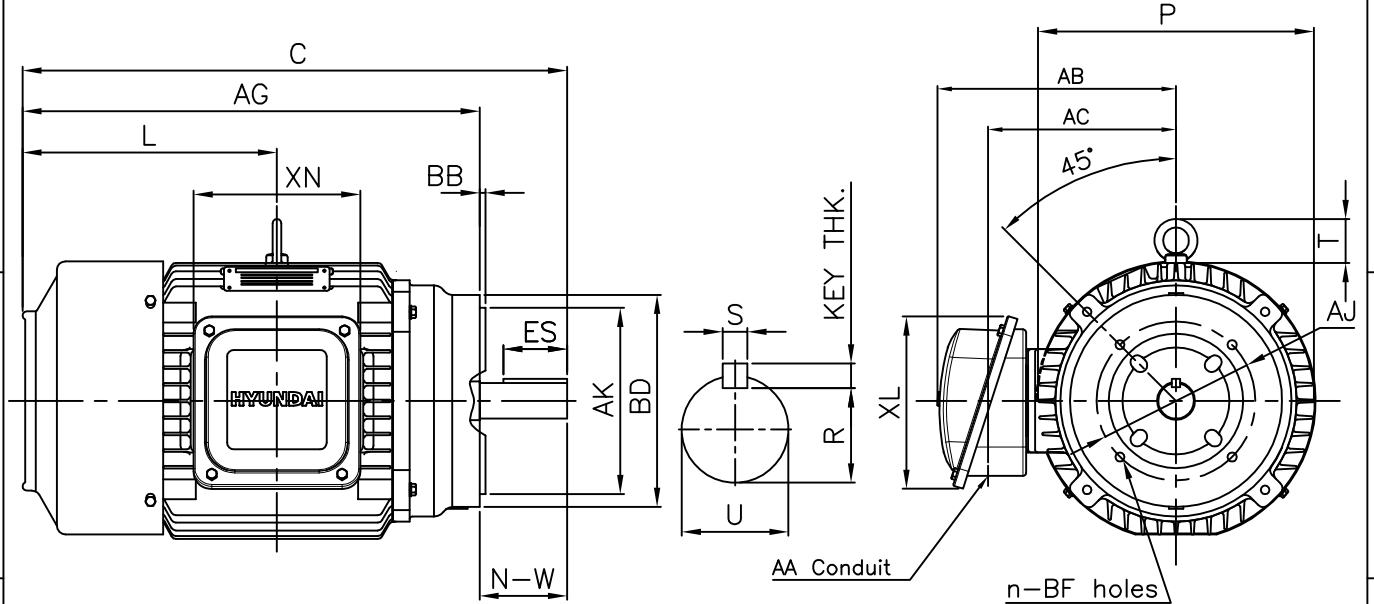

DIMENSIONS

Unit : inch

F L A N G E						CONDUIT BOX					APPROX. WGT.(LB)
AJ	AK	BD	BB	BF	n	AA	AB	AC	XL	XN	
7.25	8.50	9.68	0.25	1/2-13	4	1.25	11.85	8.46	8.43	8.19	300

O V E R A L L					S H A F T					KEY THK.	B E A R I N G	
AG	C	L	P	T	U	N-W	KEYWAY				DRIVE END	OPP. DRIVE END
							R	ES	S			
20.93	24.93	11.68	12.76	2.01	1.625	4.00	1.416	2.91	0.375	0.375	6309ZC3	6309ZC3

NOTE

1. Dimension "U" tolerance : +0.000inch - 0.001inch
2. Dimension "R" tolerance : +0.000inch - 0.015inch
3. Dimension "AK" tolerance : +0.000inch - 0.003inch

APPD BY	S.Y.KIM	UNIT	INCH	SUBJECT	NEMA 256TC	DWG SIZE	A4 (1:1)
CHKD BY	R.G.KIM	SCALE	NONE	TITLE	OUTLINE	REF. NO	350A8508AA
CHKD BY	Y.H.BAE	PROJEC'N	3각법 (3rd Angle)	DWG NO		LM-I1256C5PL001	Sheet No.
DSND BY	H.K.LEE	DATE	2021-04-30			Revision No.	0



Cls. I&II, Div. 2 IEEE 841

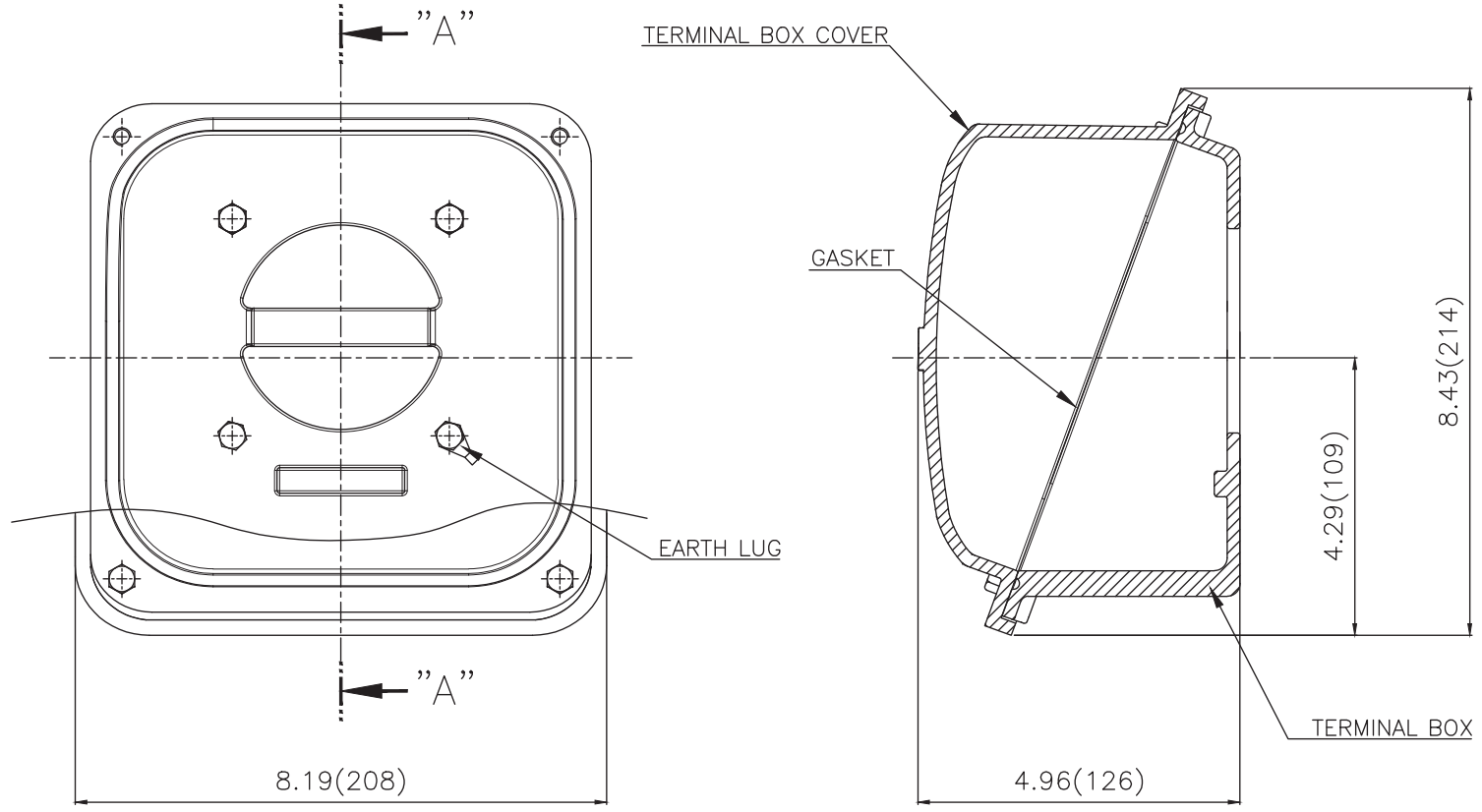

▽	50S
▽▽	12.5S
▽▽▽	3.2S
▽▽▽▽	0.4S

REV	DATE	CONTENTS	REVD BY	CHKD BY	CHKD BY	APPD BY

일반가공공차		일반제관공차	
1-4	±0.1	6-30	±0.5
4-18	±0.2	30-120	±0.8
18-63	±0.3	120-315	±1.2
63-250	±0.5	315-1000	±2.0
250-	±0.8	1000-	±3.0

Q'TY	DESCRIPTION	MATERIAL	DIMENSION	WEIGHT	PART NO.	REMARK	NO.
APPD BY	S.Y.KIM	UNIT	inch(mm)	SUBJECT	FR. 250-280 (CAST IRON)	DWG SIZE	
CHKD BY		SCALE	1/2	TITLE	TERMINAL BOX ASS'Y		
CHKD BY	R.G.KIM	PROJEC'N	3rd Angle				
DSND BY	배승희	DATE	2023-10-19				
				REF. NO		Sheet No.	of
				DWG NO	3M-248458	Revision No.	0

