

Customer :  
Project Name :  
Project No. :  
Revision No. :

# SPECIFICATION for INDUCTION MOTOR



0		For Bidding			
No.	DATE	DESCRIPTION	PREPARED BY	CHECKED BY	APPROVED BY



# AC INDUCTION MOTOR DATA SHEET

## IEEE841 TYPE

Catalog No.	IEEE20-18-256TC	Item No.	Rev. No.	[      ]
Project Name		Project No.	Quantity	sets

GENERAL SPECIFICATION			PERFORMANCE DATA			
Frame Size	256TC		Rated Output	15 kW      20 HP		
Type	PJP		Number of Poles	4		
Enclosure(Protection)	Totally Enclosed / IP55		Rotor Type	Squirrel Cage		
Method of Cooling	IC411(FC)		Starting Method*	D.O.L		
Rated Frequency	60 Hz		Rated Voltage	575 V	460 V	230 V
Number of Phases	3		Current	Full Load	19.9 A	24.8 A      49.7 A
Insulation Class	F			Locked-rotor**	800 %	800 %      800 %
Temp. Rise at full load (by resistance method)			Efficiency			
at 1.0 S.F			80 deg. C		50% Load      90.0 %	
Motor Location	<input type="checkbox"/> Indoor <input type="checkbox"/> Outdoor		75% Load		92.0 %	
Altitude	Less than 1,000 meter		100% Load		93.0 %	
Relative Humidity	Less than 80 %		Power Factor(p.u)			
Ambient Temp.	40 deg. C (Max.)		50% Load		0.665	
Duty Type	Continuous ( S1 )		75% Load		0.765	
Service Factor	1.15		100% Load		0.815	
Mounting	B35		Speed at Full Load	1775 r.p.m		
Bearing	Type	Anti-Friction	Torque			
	DE/N-DE	6309ZC3 / 6309ZC3	Full Load	59.5 lb.ft		
	Lubricant	Grease(Polyrex-EM)	Locked-rotor**	200 %		
External Thrust	Not applicable		Breakdown**	240 %		
Coupling Method	<input checked="" type="checkbox"/> Direct <input type="checkbox"/> V-belt		Moment of Inertia (J)			
Shaft Extension	Single		Load(Max.)	122.210 lb.ft2		
Terminal Box	Main	Cast Iron	Motor	2.635 lb.ft2		
	Aux.	No	Sound Pressure Level (No-load & mean value at 1m from motor)			
	Location	Refer to Outline Drawing	74 dB(A)			
Application			Vibration      3.8 mm/sec (peak)			
Area classification	Hazardous		Permissible number of consecutive starts	Cold	3 times	
Type of Ex-Protection	Class I&II, Division 2			Hot	2 times	
Applicable Standard	IEEE841, NEMA MG1, CSA C390		Paint	Munsell No.	7.5BG6/1.5	

ACCESSORIES

SUBMITTAL DRAWING		
Outline Dimension Drawing	Motor Weight(Approx.)	
B35	LM-I1256C4PL001	300 lb.

SPARE PARTS

REMARK				
1. Premium efficiency according to NEMA MG1 2. Inverter Duty @ 1.0 Service Factor & F Temperature rise -. 10:1 VT (20:1 VT at 50% load) -. 10:1 CT -. CHP up to 1.5 times base speed, NEMA MG1 Part31 3. CSA Certification -. Class I, Division 2, Group A, B, C & D -. Class II, Division 2 Group E, F & G (Group E : up to 320Fr.) 4. Service Factor 1.15 and Temperature rise B are applicable under the condition of sine wave power. 5. Service Factor 1.25 is applicable to motors of 100HP or less with temperature rise F & Non-Hazardous.				
Date	DSND	CHKD	CHKD	APPD
2024-07-13	S.H. Lee	I.K. Kim	R.G. Kim	S.W. Kim

[Note] Others not mentioned in this data sheet shall be in accordance with maker standard.  
 Above technical data are only design values and shall be guaranteed with tolerance of applicable standard.  
 Inspection and performance test shall be done according to maker standard, if not mentioned.  
 \* In case of Inverter-Fed Motor, performance data is based on sine wave tests. It may be different from test data of Inverter combined motor.  
 \*\* Data is based on rated voltage & frequency and is expressed as a percentage of full-load value.

1	2	3	4
REV	DATE	CONTENTS	REVD BY   CHKD BY   CHKD BY   APPD BY

4.72

20HP	4P	460V	Cat. No.	IEEE20-18-256TC				
Model	HLS256PR23		INS. Class	F	HD-F1	Amps	24.8	
Type	HLS	Duty	CONT	Code	J	Amb.	40°C	
Frame	256TC	Encl.	TEFC	S.F.	1.15	RPM	1775	
Bearing	Drive	6309ZC3		S.F.1.00 (10:1 C.T., 20:1 V.T., NEMA-MG1 Part31)		3/4 Eff.	92%	
	Opp.	6309ZC3				NEMA Design	B Torque	
Usable at	50Hz 15HP 380V 26.3A 1475rpm S.F.: 1.0 Eff.: 89.8% Code: L							
	50Hz 15HP 400/415V 26.4/27.1A 1480/1480rpm S.F.: 1.0 Eff.: 89.8/89.8% Code: L/L							
CSA Certified for	Model	LATER		Type	PJP			
	CLASS I, Div. 2, Gr. A, B, C & D CLASS I, Zone 2, Gr. IIA, IIB, & IIC	CLASS II, Div. 2, Gr. E, F & G (Gr. E : Up to 320FR)		Temp. Code (sine wave)	Frame	140~320FR	360~400FR	440FR
		Amb. 40°C	T3C (160°C)		T3B (165°C)	T3A (180°C)		
Amb. 55°C	T3A (180°C)	T3A (180°C)	T3 (200°C)					
No.	-		Date	-		Weight	300 lb	

**IEEE Std 841-2021**

4M-135701

**MARINE DUTY IEEE45**

Made in Korea H1

2.36

APPD BY	S.Y.KIM	UNIT	INCH	SUBJECT	CSA Class I, Division2 IEEE841 (HL)	DWG SIZE
CHKD BY	I.K.KIM	SCALE	NONE			A4 ( 1:1 )
CHKD BY	R.G.KIM	PROJEC'N	3rd Angle	TITLE <b>NAMEPLATE DRAWING</b>		
DSND BY	S.H.LEE	DATE	2024.06.07			
				REF. NO	<b>4M-135701</b>	Sheet No. of
				DWG NO	<b>NP-IEEE20-18-256TC</b>	Revision No. <b>0</b>

Type :	PJP
Full Load Torque :	59.5 lb.ft
Load moment of Inertia (J) :	122.210 lb.ft <sup>2</sup>
Motor moment of Inertia (J) :	2.635 lb.ft <sup>2</sup>

15kW	20HP	4 P	60 Hz
Speed at Full Load :			1775 RPM
Rated Voltage	575V	460V	230V
Full Load Current	19.9A	24.8A	49.7A

SPEED VS TORQUE & CURRENT CURVE

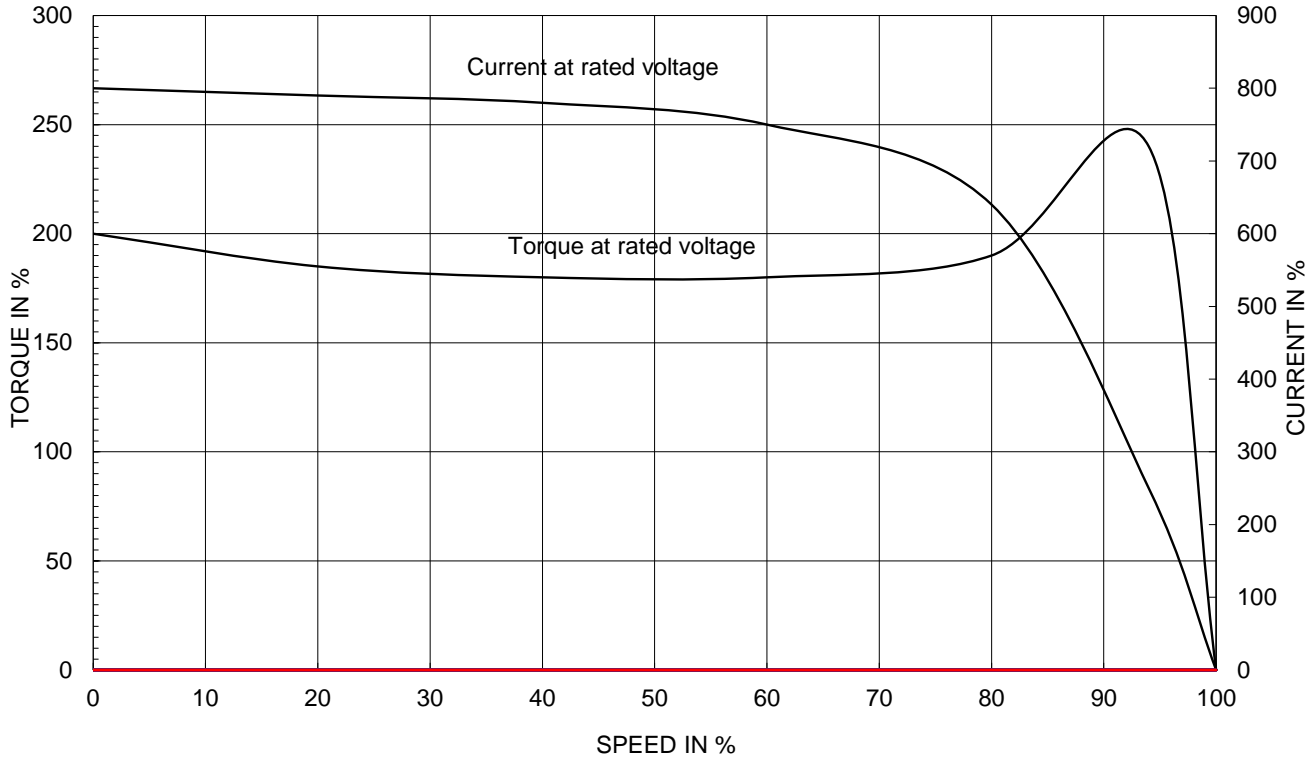

OUTPUT VS EFF., P.F & CURRENT CURVE

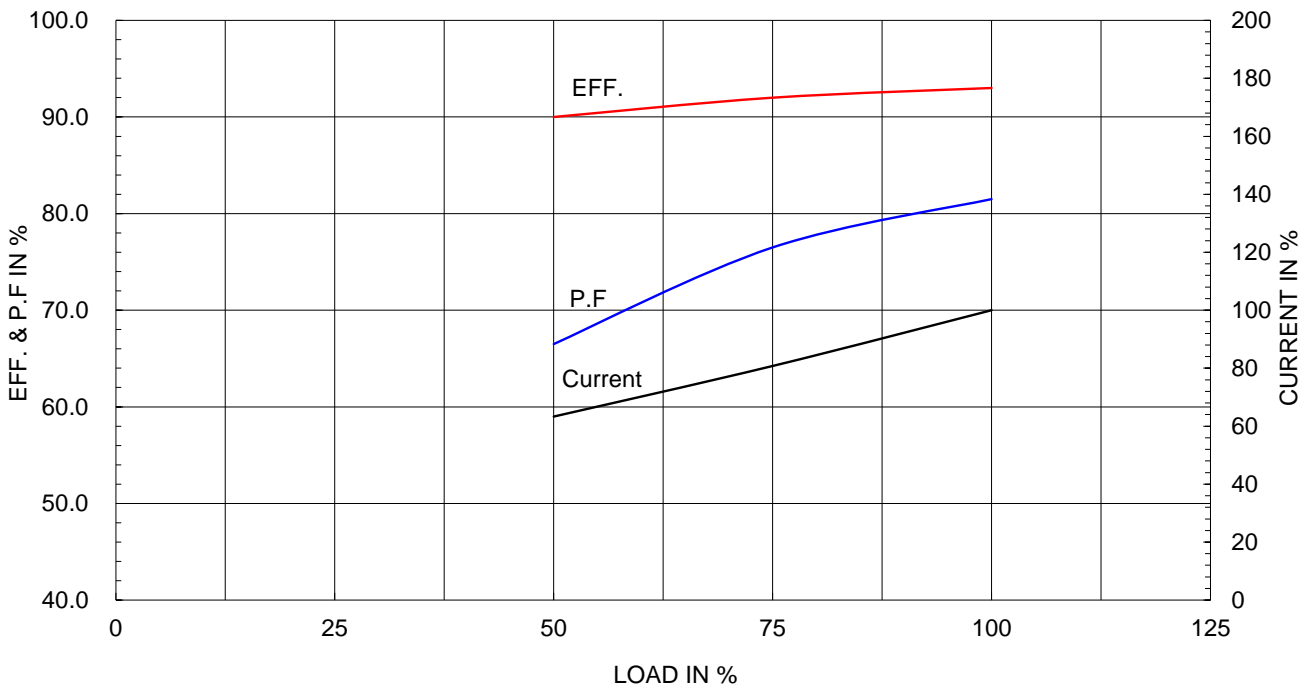

본 도면은 HD현대일렉트릭(주) 재산이며 허기없이 복사할 수 없음 (취급유의)

THIS DRAWING IS PROPRIETARY TO HYUNDAI ELECTRIC. NO PART OF THIS DRAWING MAYBE REPRODUCED WITHOUT THE PERMISSION OF HYUNDAI ELECTRIC.

▽	50S	REV	DATE	CONTENTS	REV'D BY	CHKD BY	CHKD BY	APPD BY
▽▽	12.5S							
▽▽▽	3.2S							
▽▽▽▽	0.4S							

**IEEE841**

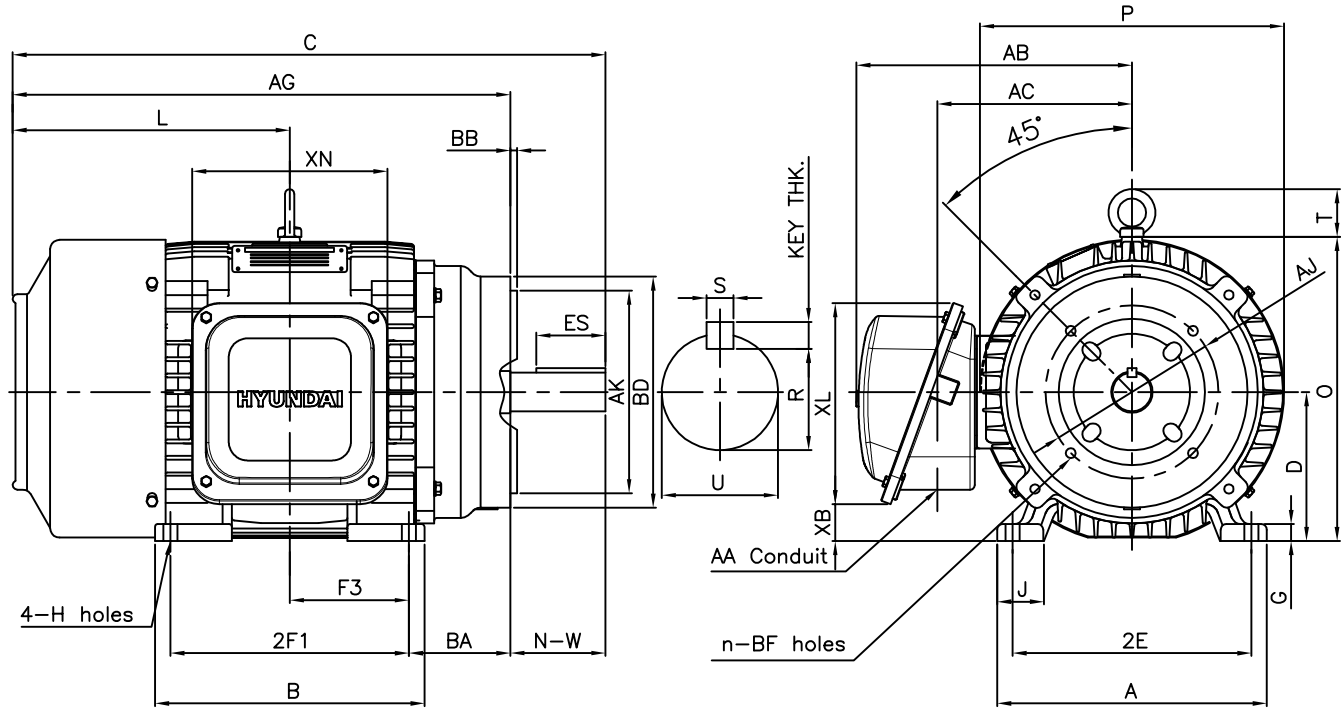

DIMENSIONS

Unit : inch

F L A N G E						M O U N T I N G								
AJ	AK	BD	BB	BF	n	A	B	2E	2F1	2F2	F3	G	J	H
7.25	8.50	9.68	0.25	1/2-13	4	11.30	11.30	10.00	10.00	-	5.00	0.72	1.93	0.53

C O N D U I T B O X						O V E R A L L								APPROX. WGT.(LB)
AA	AB	AC	XB	XL	XN	AG	BA	C	D	L	O	P	T	
1.25	11.85	8.46	2.64	8.43	8.19	20.86	4.25	24.86	6.25	11.61	12.75	12.76	2.01	300

S H A F T					KEY THK.	B E A R I N G	
U	N-W	KEYWAY				DRIVE END	OPP. DRIVE END
		R	ES	S			
1.625	4.00	1.416	2.91	0.375	0.375	6309ZC3	6309ZC3

**NOTE**

- 1.Dimension "D" tolerance : +0.00inch - 0.03inch
- 2.Dimension "U" tolerance : +0.000inch - 0.0005inch
- 3.Dimension "R" tolerance : +0.000inch - 0.015inch

APPD BY	S.Y.KIM	UNIT	INCH	SUBJECT	NEMA 256TC(KIT)	DWG SIZE	A4 ( 1:1 )
CHKD BY	R.G.KIM	SCALE	NONE	TITLE	OUTLINE	REF. NO	350A8308AA
CHKD BY	Y.H.BAE	PROJEC'N	3각법(3rd Angle)				
DSND BY	H.K.LEE	DATE	2021-05-06				



REF. NO	350A8308AA	Sheet No.	of
DWG NO	LM-I1256C4PL001	Revision No.	0



# Cls. I&II, Div. 2 IEEE 841

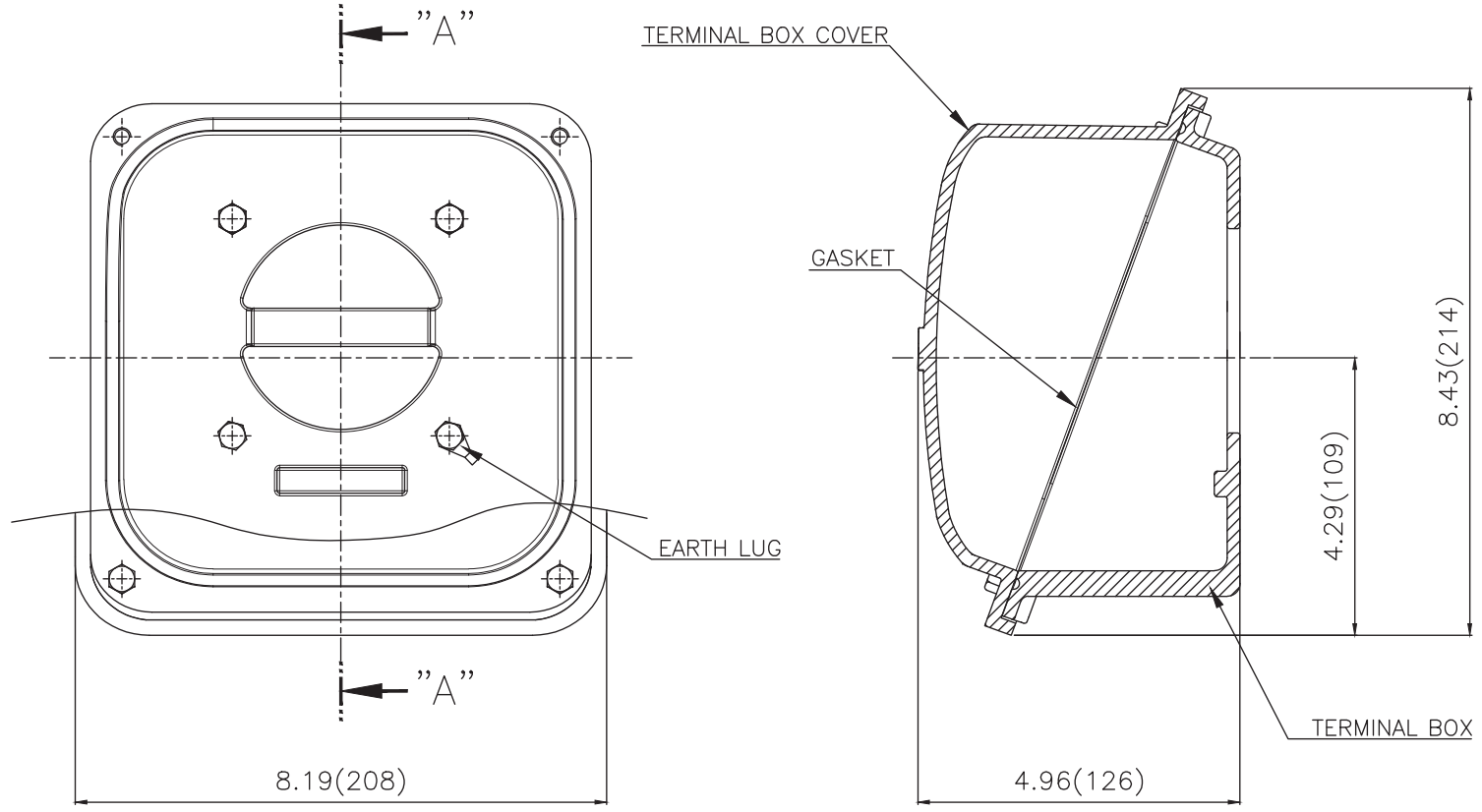

▽	50S
▽▽	12.5S
▽▽▽	3.2S
▽▽▽▽	0.4S

REV	DATE	CONTENTS	REVD BY	CHKD BY	CHKD BY	APPD BY

일반가공공차		일반제관공차	
1-4	±0.1	6-30	±0.5
4-18	±0.2	30-120	±0.8
18-63	±0.3	120-315	±1.2
63-250	±0.5	315-1000	±2.0
250-	±0.8	1000-	±3.0

Q'TY	DESCRIPTION	MATERIAL	DIMENSION	WEIGHT	PART NO.	REMARK	NO.
APPD BY	S.Y.KIM	UNIT	inch(mm)	SUBJECT	FR. 250-280 (CAST IRON)	DWG SIZE	
CHKD BY		SCALE	1/2	TITLE		A3 ( 1:2 )	
CHKD BY	R.G.KIM	PROJEC'N	3rd Angle	TERMINAL BOX ASS'Y			
DSND BY	배승희	DATE	2023-10-19	REF. NO		Sheet No.	of
				DWG NO	3M-248458	Revision No.	0