

Customer :  
Project Name :  
Project No. :  
Revision No. :

# SPECIFICATION for INDUCTION MOTOR



0		For Bidding			
No.	DATE	DESCRIPTION	PREPARED BY	CHECKED BY	APPROVED BY



# AC INDUCTION MOTOR DATA SHEET

## IEEE841 TYPE

Catalog No.	IEEE2-36-145TC	Item No.	Rev. No.	[      ]
Project Name		Project No.	Quantity	sets

GENERAL SPECIFICATION		PERFORMANCE DATA			
Frame Size	145TC	Rated Output	1.5 kW      2 HP		
Type	PJP	Number of Poles	2		
Enclosure(Protection)	Totally Enclosed / IP55	Rotor Type	Squirrel Cage		
Method of Cooling	IC411(FC)	Starting Method*	D.O.L		
Rated Frequency	60 Hz	Rated Voltage	575 V	460 V	230 V
Number of Phases	3	Current	Full Load	2.07 A	2.59 A
Insulation Class	F		Locked-rotor**	950 %	950 %
Temp. Rise at full load (by resistance method)		Efficiency			
at 1.0 S.F	80 deg. C	50% Load		82.5 %	
Motor Location	<input type="checkbox"/> Indoor <input type="checkbox"/> Outdoor	75% Load		84.5 %	
Altitude	Less than 1,000 meter	100% Load		85.5 %	
Relative Humidity	Less than 80 %	Power Factor(p.u)			
Ambient Temp.	40 deg. C (Max.)	50% Load		0.700	
Duty Type	Continuous ( S1 )	75% Load		0.800	
Service Factor	1.15	100% Load		0.850	
Mounting	B35	Speed at Full Load	3480 r.p.m		
Bearing	Type	Anti-Friction	Torque		
	DE/N-DE	6205ZC3 / 6204ZC3	Full Load	3.0 lb.ft	
	Lubricant	Grease(Polyrex-EM)	Locked-rotor**	180 %	
External Thrust	Not applicable	Breakdown**	250 %		
Coupling Method	<input checked="" type="checkbox"/> Direct <input type="checkbox"/> V-belt	Moment of Inertia (J)			
Shaft Extension	Single	Load(Max.)	2.729 lb.ft2		
Terminal Box	Main	Cast Iron	Motor	0.042 lb.ft2	
	Aux.	No	Sound Pressure Level (No-load & mean value at 1m from motor)		
Location	Refer to Outline Drawing			69 dB(A)	
Application		Vibration		3.8 mm/sec (peak)	
Area classification	Hazardous	Permissible number of consecutive starts	Cold	3 times	
Type of Ex-Protection	Class I&II, Division 2		Hot	2 times	
Applicable Standard	IEEE841, NEMA MG1, CSA C390	Paint	Munsell No.	7.5BG6/1.5	

ACCESSORIES

SUBMITTAL DRAWING		
Outline Dimension Drawing	Motor Weight(Approx.)	
B35	LM-II145C4PL001	55 lb.

SPARE PARTS

REMARK				
1. Premium efficiency according to NEMA MG1 2. Inverter Duty @ 1.0 Service Factor & F Temperature rise -. 10:1 VT (20:1 VT at 50% load) -. 10:1 CT -. CHP up to 1.5 times base speed, NEMA MG1 Part31 3. CSA Certification -. Class I, Division 2, Group A, B, C & D -. Class II, Division 2 Group E, F & G (Group E : up to 320Fr.) 4. Service Factor 1.15 and Temperature rise B are applicable under the condition of sine wave power. 5. Service Factor 1.25 is applicable to motors of 100HP or less with temperature rise F & Non-Hazardous.				
Date	DSND	CHKD	CHKD	APPD
2024-07-13	S.H. Lee	I.K. Kim	R.G. Kim	S.W. Kim

[Note] Others not mentioned in this data sheet shall be in accordance with maker standard.  
 Above technical data are only design values and shall be guaranteed with tolerance of applicable standard.  
 Inspection and performance test shall be done according to maker standard, if not mentioned.  
 \* In case of Inverter-Fed Motor, performance data is based on sine wave tests. It may be different from test data of Inverter combined motor.  
 \*\* Data is based on rated voltage & frequency and is expressed as a percentage of full-load value.

본 도면은 HD현대일렉트릭(주) 재산이며 허가없이 복사할 수 없음 (취급주의)

THIS DRAWING IS PROPRIETARY TO HYUNDAI ELECTRIC. NO PART OF THIS DRAWING MAYBE REPRODUCED WITHOUT THE PERMISSION OF HYUNDAI ELECTRIC.

1	2	3	4
REV	DATE	CONTENTS	REVD BY

4.02

1.81

**CROWN TRITON**  
Premium Efficiency AC 3 Phase Motor

2HP	2P	460V	Cat. No.	IEEE2-36-145TC	
Model	HLS145PL138	INS. Class	F	HD-F1	Amps 2.59
Type	HLS	Duty	CONT	Code	L
Frame	145TC	Encl.	TEFC	RPM	3480
<input type="checkbox"/>	Drive	6205ZC3	S.F.	1.15	NEMA Design B
	Opp.	6204ZC3	S.F.1.00(10:1 C.T., 20:1 V.T., NEMA-MG1 Part31)		
Usable at					
50Hz 1.5HP 380V 2.7A 2890rpm S.F.: 1.0 Eff.: 79.6% Code: L					
50Hz 1.5HP 400/415V 2.6/2.6A 2900/2905rpm S.F.: 1.0 Eff.: 79.6/79.6% Code: L/L					
CSA Certified for	Model	LATER	Type	PJP	Temp. Code
	CLASS I, Div 2, Gr A, B, C & D		CLASS II, Div 2, Gr E, F & G		(sine wave)
	CLASS I, Zone 2, Gr IIA, IIB & IIC				
No.	-	Date	-	Weight	55 lb

**IEEE Std 841-2021**

NP249A7178RCP1

**MARINE DUTY IEEE45**

Made in Korea H3

APPD BY	S.Y.KIM	UNIT	INCH	SUBJECT	CSA Class I, Division2 IEEE841 (HL)	DWG SIZE
CHKD BY	I.K.KIM	SCALE	NONE	TITLE	NAMEPLATE DRAWING	A4 ( 1:1 )
CHKD BY	R.G.KIM	PROJEC'N	3rd Angle			
DSND BY	S.H.LEE	DATE	2024.06.07			
				REF. NO	NP249A7178R	Sheet No. of
				DWG NO	NP-IEEE2-36-145TC	Revision No. <b>0</b>

Type :	PJP
Full Load Torque :	3.0 lb.ft
Load moment of Inertia (J) :	2.729 lb.ft <sup>2</sup>
Motor moment of Inertia (J) :	0.042 lb.ft <sup>2</sup>

1.5kW	2HP	2 P	60 Hz
Speed at Full Load :			3480 RPM
Rated Voltage	575V	460V	230V
Full Load Current	2.1A	2.6A	5.2A

SPEED VS TORQUE & CURRENT CURVE

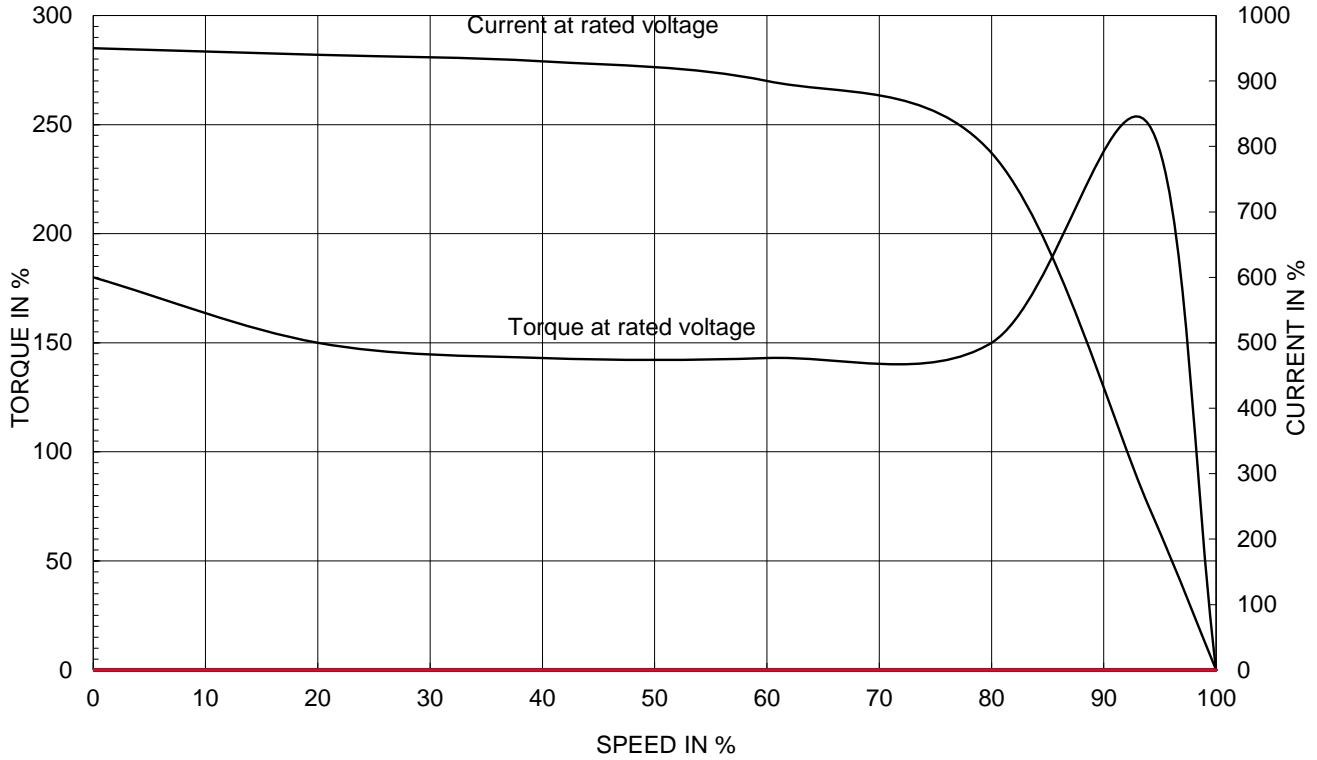

OUTPUT VS EFF., P.F & CURRENT CURVE

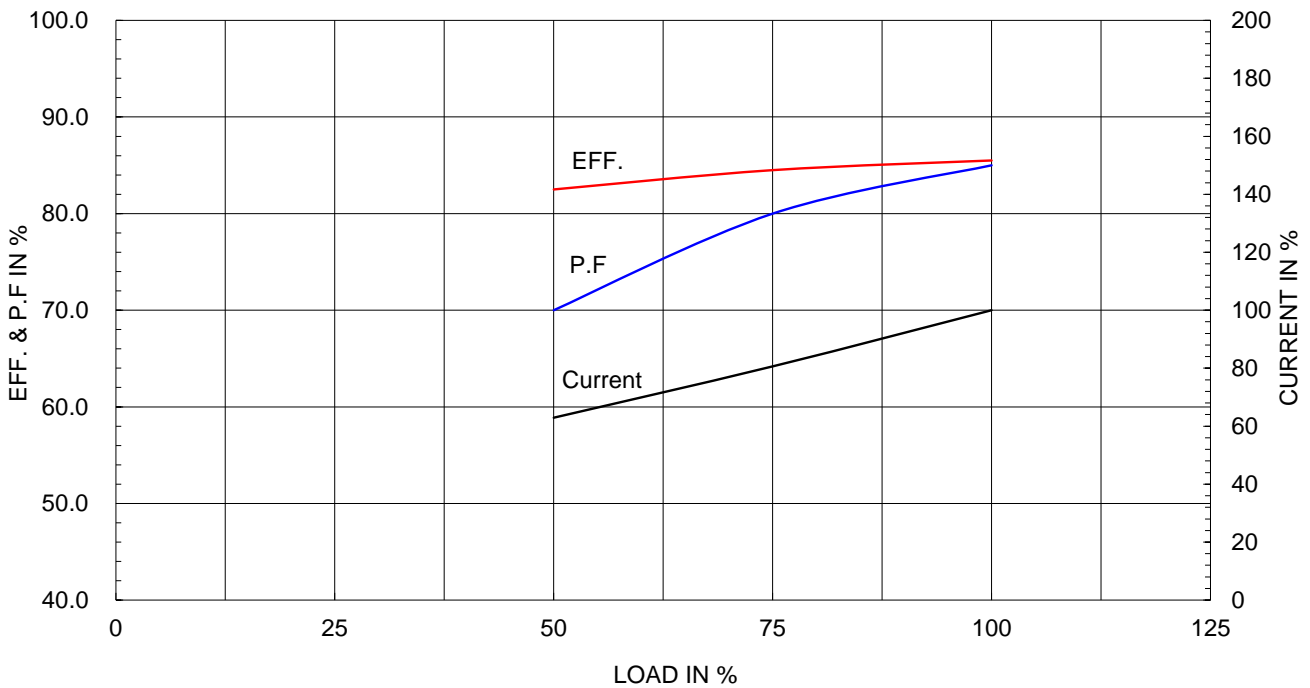

본 도면은 HD현대일렉트릭(주) 재산이며 허가없이 복사할 수 없음 (취급주의)

THIS DRAWING IS PROPRIETARY TO HYUNDAI ELECTRIC. NO PART OF THIS DRAWING MAYBE REPRODUCED WITHOUT THE PERMISSION OF HYUNDAI ELECTRIC.

▽	50S	REV	DATE	CONTENTS	REVD BY	CHKD BY	CHKD BY	APPD BY
▽▽	12.5S							
▽▽▽	3.2S							
▽▽▽▽	0.4S							

**IEEE841**

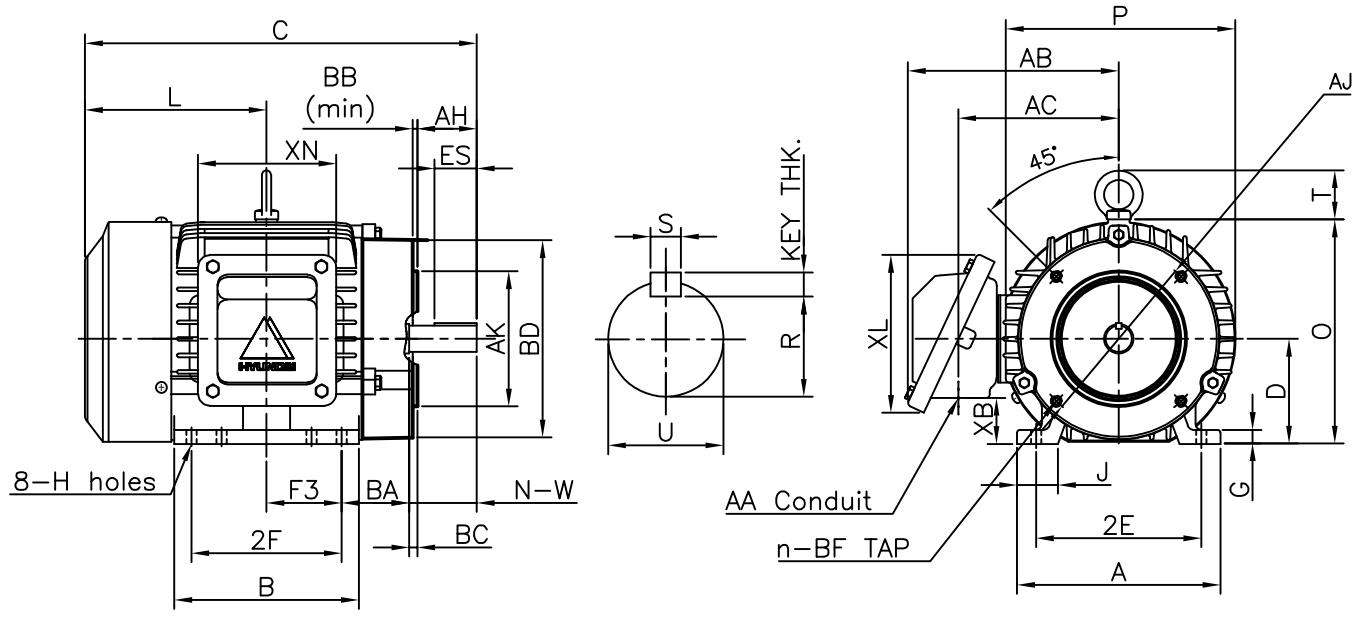

DIMENSIONS

Unit : inch

FLANGE							MOUNTING								
AJ	AK	BD	BB	BC	BF	n	A	B	2E	2F	-	F3	G	J	H
5.875	4.50	6.57	0.16	+0.12	3/8-16	4	6.78	6.15	5.50	5.00	-	2.50	0.47	1.36	0.34

CONDUIT BOX						OVERALL							APPROX. WGT.(LB)
AA	AB	AC	XB	XL	XN	BA	C	D	L	O	P	T	
0.75	7.02	5.34	1.53	5.26	4.61	2.25	13.05	3.50	6.05	7.46	7.64	1.63	55

SHAFT						KEY THK.	BEARING	
U	N-W	A-H	KEYWAY				DRIVE END	OPP. DRIVE END
			R	ES	S			
0.875	2.25	2.12	0.771	1.41	0.188	0.188	6205ZZ	6204ZZ

**NOTE**

- 1.Dimension "D" tolerance : +0.00inch - 0.03inch
- 2.Dimension "U" tolerance : +0.000inch - 0.0005inch
- 3.Dimension "R" tolerance : +0.000inch - 0.015inch

APPD BY	S.Y.KIM	UNIT	INCH	SUBJECT	NEMA 145TC(KIT)	DWG SIZE	A4 ( 1:1 )
CHKD BY	R.G.KIM	SCALE	NONE				
CHKD BY	Y.H.BAE	PROJEC'N	3각법(3rd Angle)	TITLE <b>OUTLINE</b>			
DSND BY	H.K.LEE	DATE	2021-05-06				



REF. NO	350A8302AA	Sheet No.	of
DWG NO	LM-I1145C4PL001	Revision No.	0

**Cls. I&II, Div. 2  
IEEE 841**

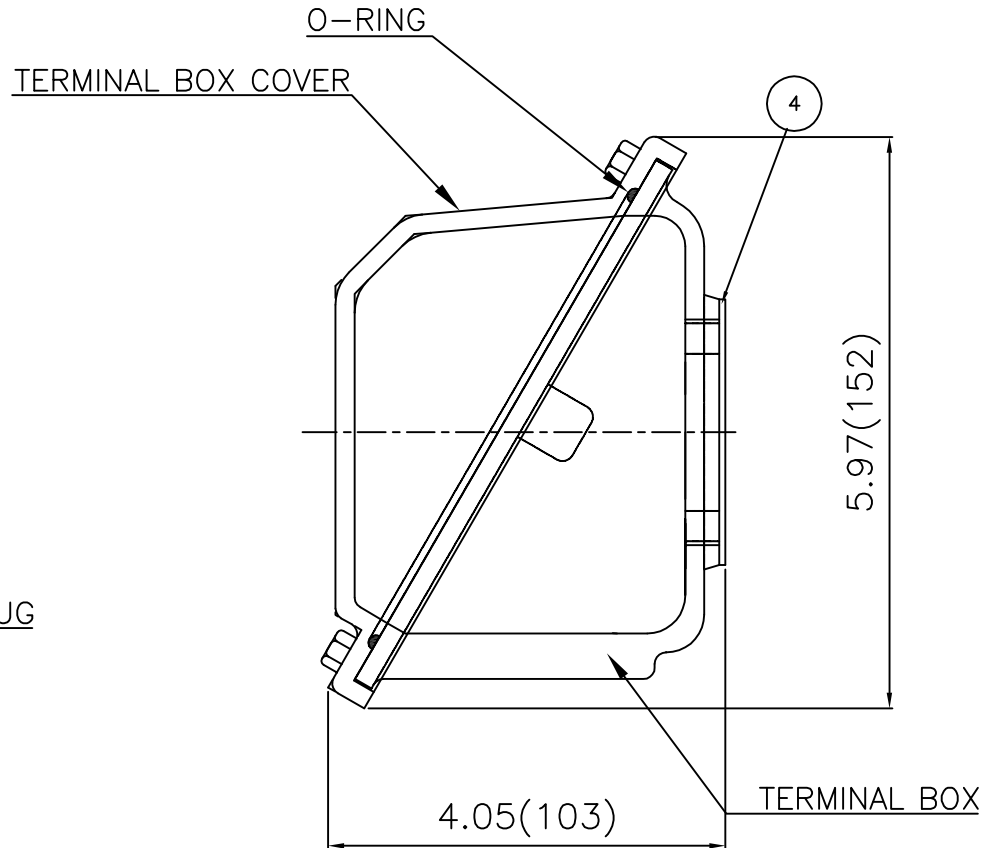
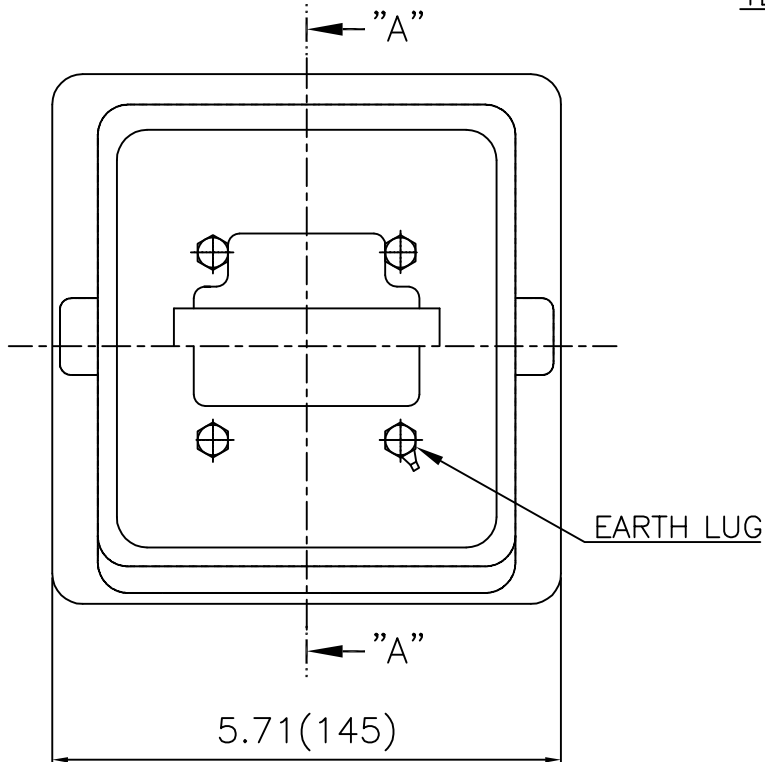

SEC. "A" - "A"

▽	50S
▽▽	12.5S
▽▽▽	3.2S
▽▽▽▽	0.4S

REV	DATE	CONTENTS	REVD BY	CHKD BY	CHKD BY	APPD BY

일반가공公差		일반재공公差	
1-4	±0.1	6-30	±0.5
4-18	±0.2	30-120	±0.8
18-63	±0.3	120-315	±1.2
63-250	±0.5	315-1000	±2.0
250-	±0.8	1000-	±3.0

Q'TY	DESCRIPTION	MATERIAL	DIMENSION	WEIGHT	PART NO.	REMARK	NO.
APPD BY	S.Y.KIM	UNIT	inch(mm)	SUBJECT	FR. 140 (CAST IRON)	DWG SIZE	A3 (1:1.5)
CHKD BY	I.K.KIM	SCALE	1/2	TITLE			
CHKD BY		PROJEC'N	3rd Angle	TERMINAL BOX ASS'Y			
DSND BY	E.J.KIM	DATE	2024-02-02	REF. NO		Sheet No.	of
		DWG NO	3M-249376	Revision No. 0			