

Customer :
Project Name :
Project No. :
Revision No. :

SPECIFICATION for INDUCTION MOTOR



0		For Bidding			
No.	DATE	DESCRIPTION	PREPARED BY	CHECKED BY	APPROVED BY



AC INDUCTION MOTOR DATA SHEET

IEEE841 TYPE

Catalog No.	IEEE2-12-184T	Item No.	Rev. No. []
Project Name		Project No.	Quantity sets

GENERAL SPECIFICATION		PERFORMANCE DATA				
Frame Size	184T	Rated Output	1.5 kW 2 HP			
Type	PJP	Number of Poles	6			
Enclosure(Protection)	Totally Enclosed / IP55	Rotor Type	Squirrel Cage			
Method of Cooling	IC411(FC)	Starting Method*	D.O.L			
Rated Frequency	60 Hz	Rated Voltage	575 V	460 V	230 V	
Number of Phases	3	Current	Full Load	2.50 A	3.13 A	6.26 A
Insulation Class	F		Locked-rotor**	790 %	790 %	790 %
Temp. Rise at full load (by resistance method)		Efficiency				
at 1.0 S.F	80 deg. C	50% Load		85.5 %		
Motor Location	<input type="checkbox"/> Indoor <input type="checkbox"/> Outdoor	75% Load		87.5 %		
Altitude	Less than 1,000 meter	100% Load		88.5 %		
Relative Humidity	Less than 80 %	Power Factor(p.u)				
Ambient Temp.	40 deg. C (Max.)	50% Load		0.530		
Duty Type	Continuous (S1)	75% Load		0.630		
Service Factor	1.15	100% Load		0.680		
Mounting	B3	Speed at Full Load		1175 r.p.m		
Bearing	Type	Anti-Friction				
	DE/N-DE	6206ZC3 / 6206ZC3				
	Lubricant	Grease(Polyrex-EM)				
External Thrust	Not applicable					
Coupling Method	<input checked="" type="checkbox"/> Direct <input type="checkbox"/> V-belt	Torque				
Shaft Extension	Single	Full Load		9.0 lb.ft		
Terminal Box	Main	Cast Iron				
	Aux.	No				
	Location	Refer to Outline Drawing				
Application		Locked-rotor**		180 %		
Area classification	Hazardous	Breakdown**		260 %		
Type of Ex-Protection	Class I&II, Division 2	Moment of Inertia (J)				
Applicable Standard	IEEE841, NEMA MG1, CSA C390	Load(Max.)		42.358 lb.ft2		
		Motor		0.712 lb.ft2		
		Sound Pressure Level (No-load & mean value at 1m from motor)				
		55 dB(A)				
		Vibration				
		3.8 mm/sec (peak)				
		Permissible number of consecutive starts		Cold 3 times		
				Hot 2 times		
		Paint	Munsell No.	7.5BG6/1.5		

ACCESSORIES

SUBMITTAL DRAWING		
Outline Dimension Drawing	Motor Weight(Approx.)	
B3	LM-I2184B3PLV23	105 lb.

SPARE PARTS

REMARK				
1. Premium efficiency according to NEMA MG1 2. Inverter Duty @ 1.0 Service Factor & F Temperature rise -. 10:1 VT (20:1 VT at 50% load) -. 10:1 CT -. CHP up to 1.5 times base speed, NEMA MG1 Part31 3. CSA Certification -. Class I, Division 2, Group A, B, C & D -. Class II, Division 2 Group E, F & G (Group E : up to 320Fr.) 4. Service Factor 1.15 and Temperature rise B are applicable under the condition of sine wave power. 5. Service Factor 1.25 is applicable to motors of 100HP or less with temperature rise F & Non-Hazardous.				
Date	DSND	CHKD	CHKD	APPD
2024-07-13	S.H. Lee	I.K. Kim	R.G. Kim	S.W. Kim

[Note] Others not mentioned in this data sheet shall be in accordance with maker standard.
 Above technical data are only design values and shall be guaranteed with tolerance of applicable standard.
 Inspection and performance test shall be done according to maker standard, if not mentioned.
 * In case of Inverter-Fed Motor, performance data is based on sine wave tests. It may be different from test data of Inverter combined motor.
 ** Data is based on rated voltage & frequency and is expressed as a percentage of full-load value.

1	2	3	4
REV	DATE	CONTENTS	REVD BY

3.94

CROWN TRITON G2 Premium Efficiency AC 3 Phase Motor

Cat. No. IEE2-12-184T

2HP	6P	460V	Amps	3.13	Type	HLS	Amb.	40°C
Frame	184T	Duty	CONT	Encl.	TEFC	Model	HLS184SR338	NEMA Nom. Eff. 88.5%
RPM	1175	Hertz	60Hz	S.F.	1.15	INS. Class	F HD-F1	3/4 Eff. 87.5%
Bearing	Drive	6206ZC3	S.F.1.25 (When 100HP or less, Temp Rise F & Non-Hazardous)				NEMA Design	B
	Opp.	6206ZC3	S.F.1.00 (10:1 C.T., 20:1 V.T., NEMA-MG1 Part31)				Code	L
Usable at	50Hz 1.5HP 380V 3.9A 975rpm S.F.: 1.0 Eff.: 78.1% Code: L							
	50Hz 1.5HP 400/415V 5/4.2A 975/980rpm S.F.: 1.0 Eff.: 78.1/78.1% Code: L/L							
CSA Certified for	Model	LATER	Type	PJP	Temp. Code	Frame	140-320FR	CE
	CLASS I, Div. 2, Gr. A, B, C & D		CLASS II, Div. 2, Gr. E, F & G (Gr. E : up to 320FR)		(Sine Wave)	Amb.40°C	T3C (160°C)	
	CLASS I, Zone 2, Gr. IIA, IIB & IIC					Amb.55°C	T3A (180°C)	
No.	-		Date	-		Weight	105 lb	

MARINE DUTY IEE45
IEEE Std 841-2021

1.57

APPD BY	S.Y.KIM	UNIT	INCH	SUBJECT	CSA Class I, Division2 IEE841 (HL)	DWG SIZE
CHKD BY	I.K.KIM	SCALE	NONE			A4 (1:1)
CHKD BY	R.G.KIM	PROJEC'N	3rd Angle	TITLE NAMEPLATE DRAWING		
DSND BY	S.H.LEE	DATE	2024.06.07			



REF. NO	4M-135733	Sheet No.	of
DWG NO	NP-IEE2-12-184T	Revision No.	0



PERFORMANCE CURVE

CURVE NO.

PC-IEEE2-12-184T

Type :	PJP
Full Load Torque :	9.0 lb.ft
Load moment of Inertia (J) :	42.358 lb.ft2
Motor moment of Inertia (J) :	0.712 lb.ft2

1.5kW 2HP	6 P	60 Hz
Speed at Full Load :		1175 RPM
Rated Voltage	575V	460V 230V
Full Load Current	2.5A	3.1A 6.3A

SPEED VS TORQUE & CURRENT CURVE

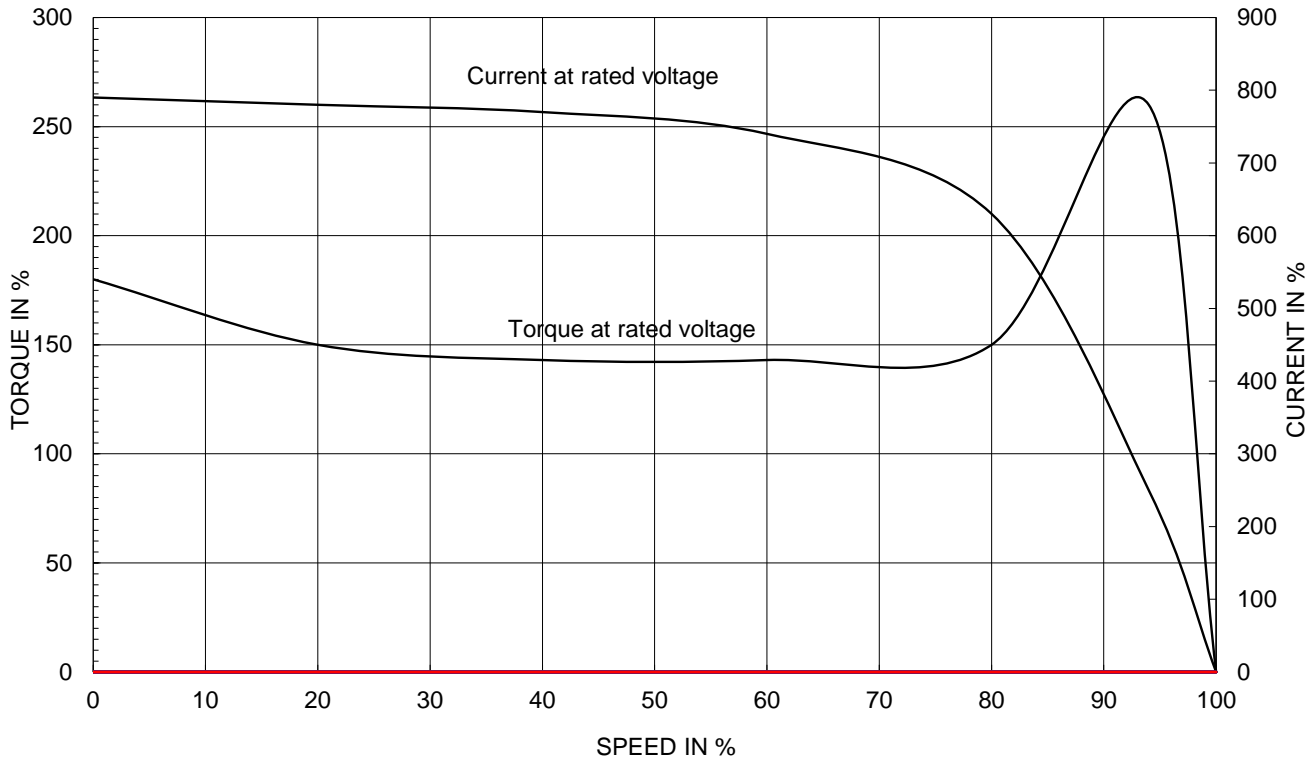

OUTPUT VS EFF., P.F & CURRENT CURVE

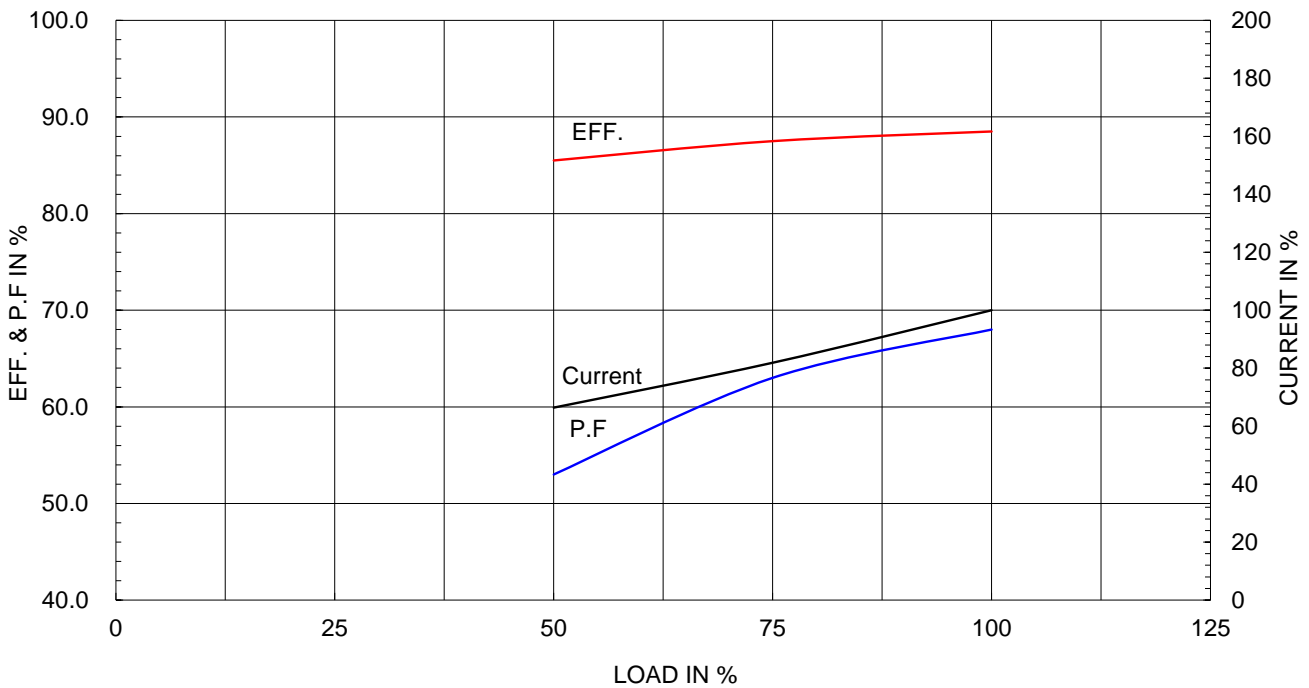

본 도면은 HD현대일렉트릭(주) 재산이며 허가없이 복사할 수 없음 (취급주의)

THIS DRAWING IS PROPRIETARY TO HYUNDAI ELECTRIC. NO PART OF THIS DRAWING MAYBE REPRODUCED WITHOUT THE PERMISSION OF HYUNDAI ELECTRIC.

1	2	3	4
▽	50S	REV	DATE
▽▽	12.5S		
▽▽▽	3.2S		
▽▽▽▽	0.4S		

IEEE841

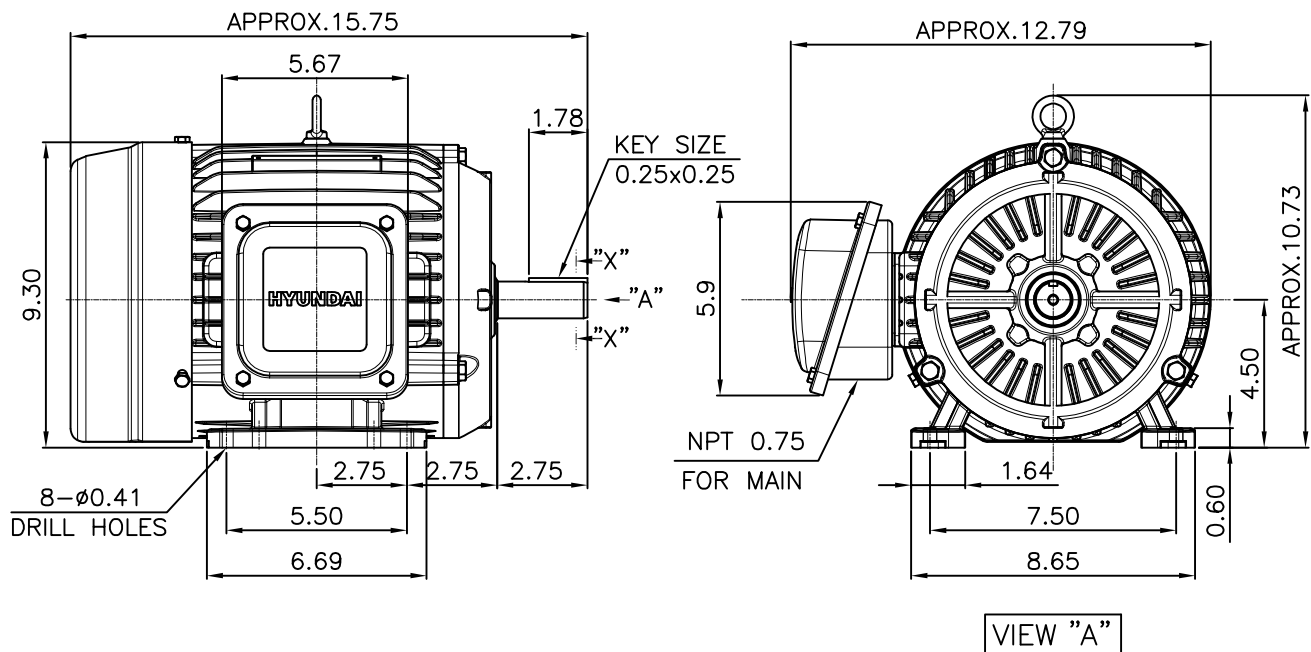

NOTE

[TOLERANCE]

- CENTER HEIGHT : +0.00inch - 0.03inch
- SHAFT DIAMETER : +0.000inch - 0.0005inch
- KEYWAY DEPTH : +0.000inch - 0.015inch

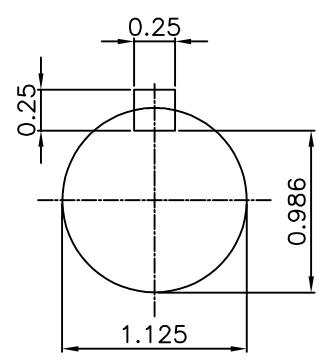

SECTION "X-X"

SCALE 5/6

APPD BY	S.Y.KIM	UNIT	mm	SUBJECT	NEMA 184T	DWG SIZE	A4 (16)
CHKD BY	R.G.KIM	SCALE	1/6	TITLE	OUTLINE		
CHKD BY		PROJEC'N	3rd Angle	REF. NO	.	Sheet No.	of
DSND BY	.H.JEON	DATE	2023-01-18	DWG NO	LM-I2184B3PLV23	Revision No.	0

**Cls. I&II, Div. 2
IEEE 841**

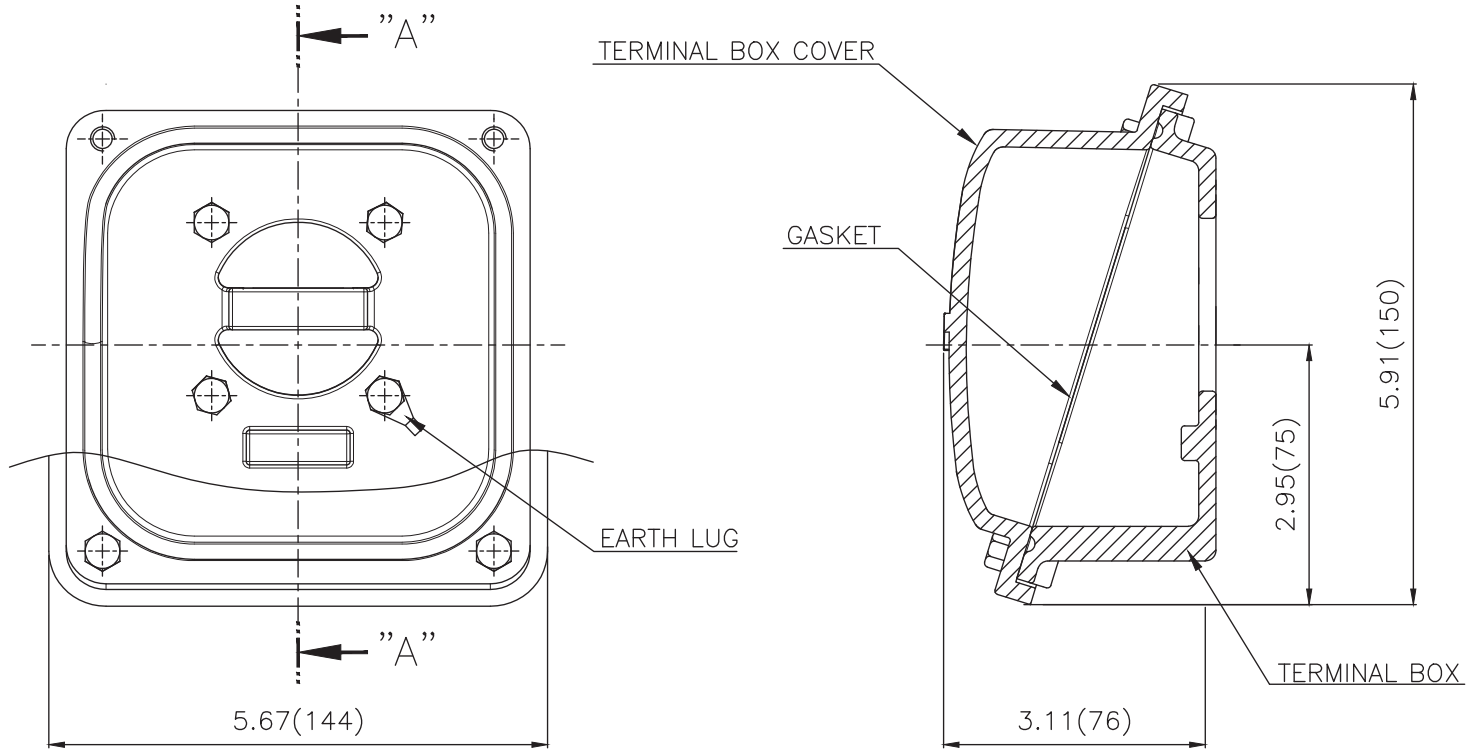

SEC. "A"-"A"

▽	50S
▽▽	12.5S
▽▽▽	3.2S
▽▽▽▽	0.4S

REV	DATE	CONTENTS	REVD BY	CHKD BY	CHKD BY	APPD BY

일반가공공차		일반제관공차	
1-4	±0.1	6-30	±0.5
4-18	±0.2	30-120	±0.8
18-63	±0.3	120-315	±1.2
63-250	±0.5	315-1000	±2.0
250-	±0.8	1000-	±3.0

Q'TY	DESCRIPTION	MATERIAL	DIMENSION	WEIGHT	PART NO.	REMARK	NO.
APPD BY	S.Y.KIM	UNIT	inch(mm)	SUBJECT	FR. 140-180 (CAST IRON)	DWG SIZE	
CHKD BY		SCALE	1/1.5	TITLE	TERMINAL BOX ASS'Y		
CHKD BY	R.G.KIM	PROJEC'N	3rd Angle	DATE	2023-10-19		
DSND BY	배승희						
REF. NO		Sheet No.	of				
DWG NO	3M-248456	Revision No.	0				

