

Customer :
Project Name :
Project No. :
Revision No. :

SPECIFICATION for INDUCTION MOTOR



0		For Bidding			
No.	DATE	DESCRIPTION	PREPARED BY	CHECKED BY	APPROVED BY



AC INDUCTION MOTOR DATA SHEET

IEEE841 TYPE

Catalog No.	IEEE150-36-445TSCRD	Item No.	Rev. No.	[]
Project Name		Project No.	Quantity	sets

GENERAL SPECIFICATION		PERFORMANCE DATA					
Frame Size	445TSC	Rated Output	110 kW 150 HP				
Type	PJP	Number of Poles	2				
Enclosure(Protection)	Totally Enclosed / IP55	Rotor Type	Squirrel Cage				
Method of Cooling	IC411(FC)	Starting Method*	D.O.L				
Rated Frequency	60 Hz	Rated Voltage	575 V	460 V	230 V		
Number of Phases	3	Current	Full Load	129.2 A	161.5 A		
Insulation Class	F		Locked-rotor**	700 %	700 %	700 %	
Temp. Rise at full load (by resistance method)		Efficiency					
at 1.0 S.F	80 deg. C	50% Load		92.0 %			
Motor Location	<input type="checkbox"/> Indoor <input type="checkbox"/> Outdoor	75% Load		94.0 %			
Altitude	Less than 1,000 meter	100% Load		95.0 %			
Relative Humidity	Less than 80 %	Power Factor(p.u)					
Ambient Temp.	40 deg. C (Max.)	50% Load		0.750			
Duty Type	Continuous (S1)	75% Load		0.850			
Service Factor	1.15	100% Load		0.900			
Mounting	B5	Speed at Full Load	3570 r.p.m				
Bearing	Type	Anti-Friction					
	DE/N-DE	6314C3 / 6314C3					
	Lubricant	Grease(Polyrex-EM)					
External Thrust	Not applicable						
Coupling Method	<input checked="" type="checkbox"/> Direct <input type="checkbox"/> V-belt	Torque					
Shaft Extension	Single	Full Load		217.1 lb.ft			
Terminal Box	Main	Locked-rotor**		120 %			
	Aux.	Breakdown**		220 %			
Box Location	Refer to Outline Drawing	Moment of Inertia (J)					
Application		Load(Max.)		293.072 lb.ft2			
Area classification	Hazardous	Motor		33.660 lb.ft2			
Type of Ex-Protection	Class I&II, Division 2	Sound Pressure Level (No-load & mean value at 1m from motor)					
Applicable Standard	IEEE841, NEMA MG1, CSA C390			85 dB(A)			
ACCESSORIES		Vibration				3.8 mm/sec (peak)	
		Permissible number of consecutive starts		Cold	3 times		
				Hot	2 times		
		Paint	Munsell No.	7.5BG6/1.5			
SPARE PARTS		SUBMITTAL DRAWING					
		Outline Dimension Drawing		Motor Weight(Approx.)			
		B5	LM-I1445C5CL003	1930 lb.			
REMARK		1. Premium efficiency according to NEMA MG1 2. Inverter Duty @ 1.0 Service Factor & F Temperature rise -. 10:1 VT (20:1 VT at 50% load) -. 10:1 CT -. CHP up to 1.5 times base speed, NEMA MG1 Part31 3. CSA Certification -. Class I, Division 2, Group A, B, C & D -. Class II, Division 2 Group E, F & G (Group E : up to 320Fr.) 4. Service Factor 1.15 and Temperature rise B are applicable under the condition of sine wave power. 5. Service Factor 1.25 is applicable to motors of 100HP or less with temperature rise F & Non-Hazardous.					
		Date	DSND	CHKD	CHKD	APPD	
		2024-07-13	S.H. Lee	I.K. Kim	R.G. Kim	S.W. Kim	

[Note] Others not mentioned in this data sheet shall be in accordance with maker standard.
 Above technical data are only design values and shall be guaranteed with tolerance of applicable standard.
 Inspection and performance test shall be done according to maker standard, if not mentioned.
 * In case of Inverter-Fed Motor, performance data is based on sine wave tests. It may be different from test data of Inverter combined motor.
 ** Data is based on rated voltage & frequency and is expressed as a percentage of full-load value.

Type :	PJP
Full Load Torque :	217.1 lb.ft
Load moment of Inertia (J) :	293.072 lb.ft2
Motor moment of Inertia (J) :	33.660 lb.ft2

110kW 150HP	2 P	60 Hz
Speed at Full Load :		3570 RPM
Rated Voltage	575V	460V 230V
Full Load Current	129.2A	161.5A 323.0A

SPEED VS TORQUE & CURRENT CURVE

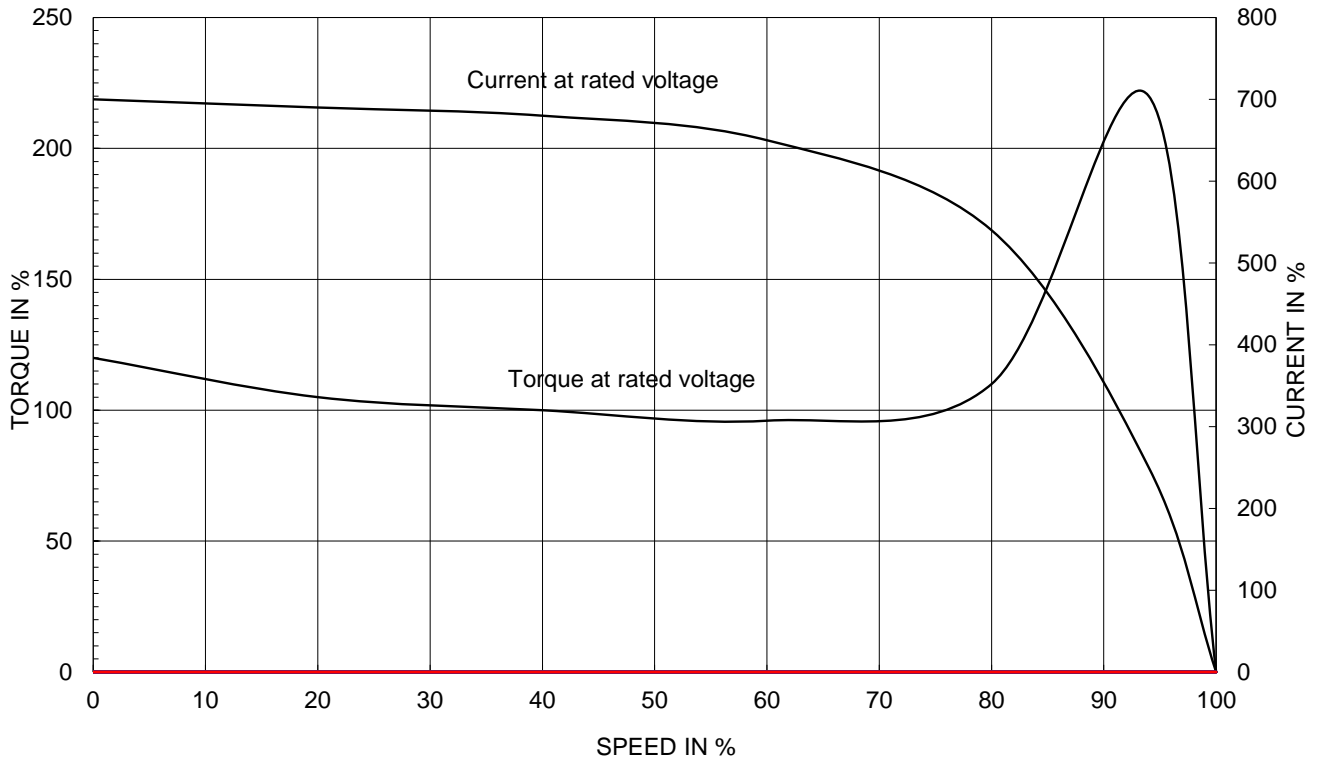

OUTPUT VS EFF., P.F & CURRENT CURVE

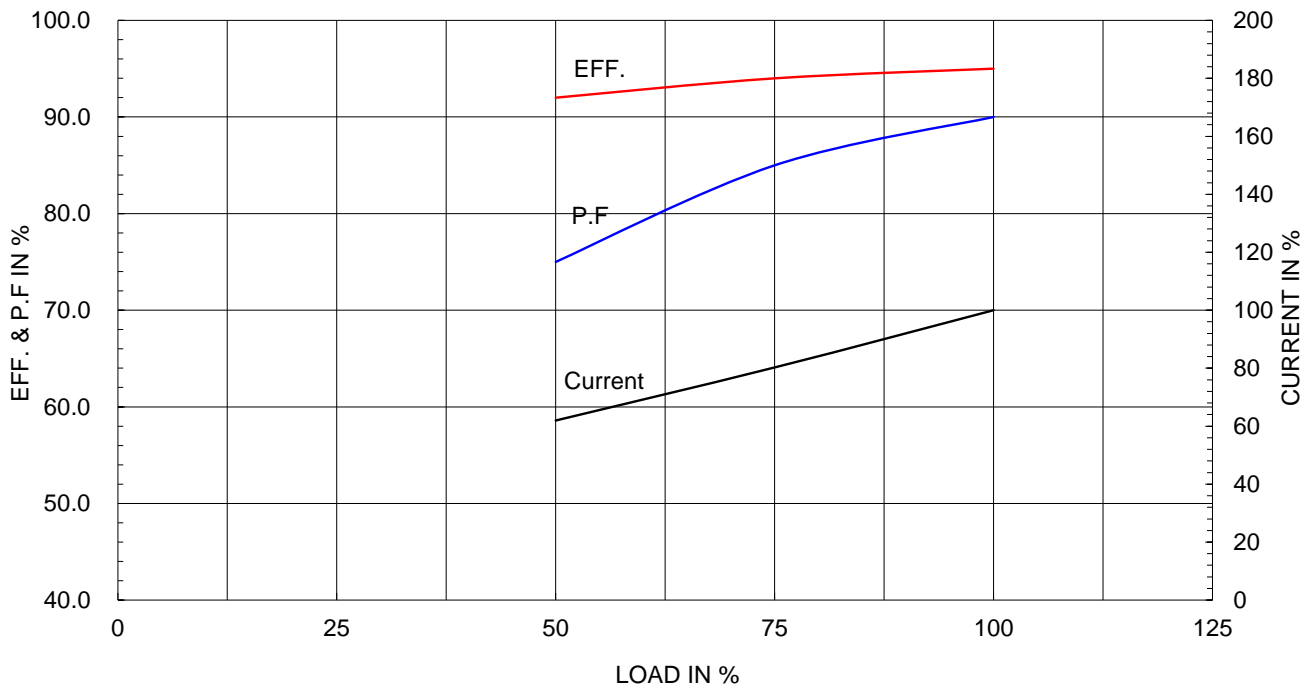

본 도면은 HD현대일렉트릭(주) 재산이며 허가없이 복사할 수 없음 (취급주의)

THIS DRAWING IS PROPRIETARY TO HYUNDAI ELECTRIC. NO PART OF THIS DRAWING MAY BE REPRODUCED WITHOUT THE PERMISSION OF HYUNDAI ELECTRIC.

1	2	3	4
▽	50S	REV	DATE
▽▽	12.5S		
▽▽▽	3.2S		
▽▽▽▽	0.4S		

IEEE841

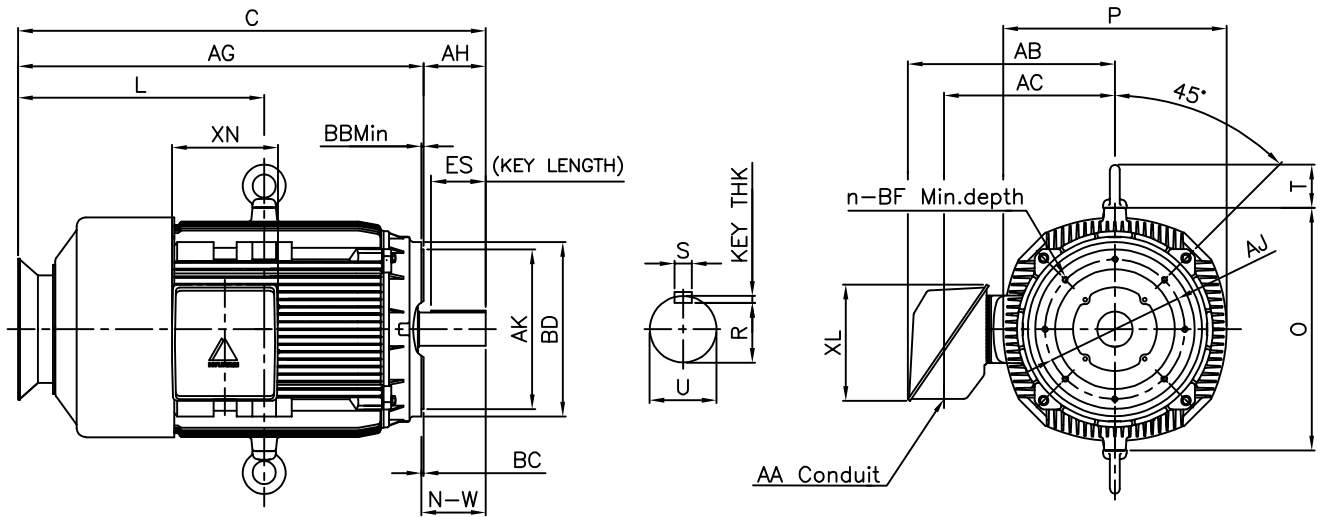

DIMENSIONS

Unit : inch

C - F A C E									CONDUIT BOX					APPROX. WGT.(LB)
AJ	AK	BB Min	BC	BD	BF	BF depth	n	AH	AA	AB	AC	XL	XN	
14.00	16.00	0.25	0.25	17.48	5/8-11	0.94	8	4.50	3.00	21.26	18.03	11.65	10.63	1930

O V E R A L L						S H A F T				KEY	BEARING		
C	L	O	P	T	AG	U	N-W	KEYWAY			THK.	DRIVE END	OPP. DRIVE END
								R	ES	S			
47.15	26.67	24.33	22.44	4.33	36.71	2.375	4.75	2.021	3.03	0.625	0.625	6314C3	6314C3

NOTE

- 1.Dimension "U" tolerance : +0.000inch ~ -0.0005inch (143TC-215TC): +0.000inch ~ -0.001inch (254TC-449TC)
- 2.Dimension "R" tolerance : +0.000inch ~ - 0.015inch
- 3.Dimension "AK" tolerance : +0.000inch ~ -0.003inch (143TC-286TC): +0.000inch ~ -0.005inch (324TC-449TC)

APPD BY	S.Y.KIM	UNIT	INCH	SUBJECT	NEMA 445TSC	DWG SIZE	A4 (1:1)		
CHKD BY	R.G.KIM	SCALE	NONE	TITLE	OUTLINE	REF. NO	350A8518BA		
CHKD BY	Y.H.BAE	PROJEC'N	3각법(3rd Angle)					Sheet No.	of
DSND BY	H.K.LEE	DATE	2021-04-30					DWG NO	LM-I1445C5CL003



REF. NO	350A8518BA	Sheet No.	of
DWG NO	LM-I1445C5CL003	Revision No.	0

**Cls. I&II, Div. 2
IEEE 841**

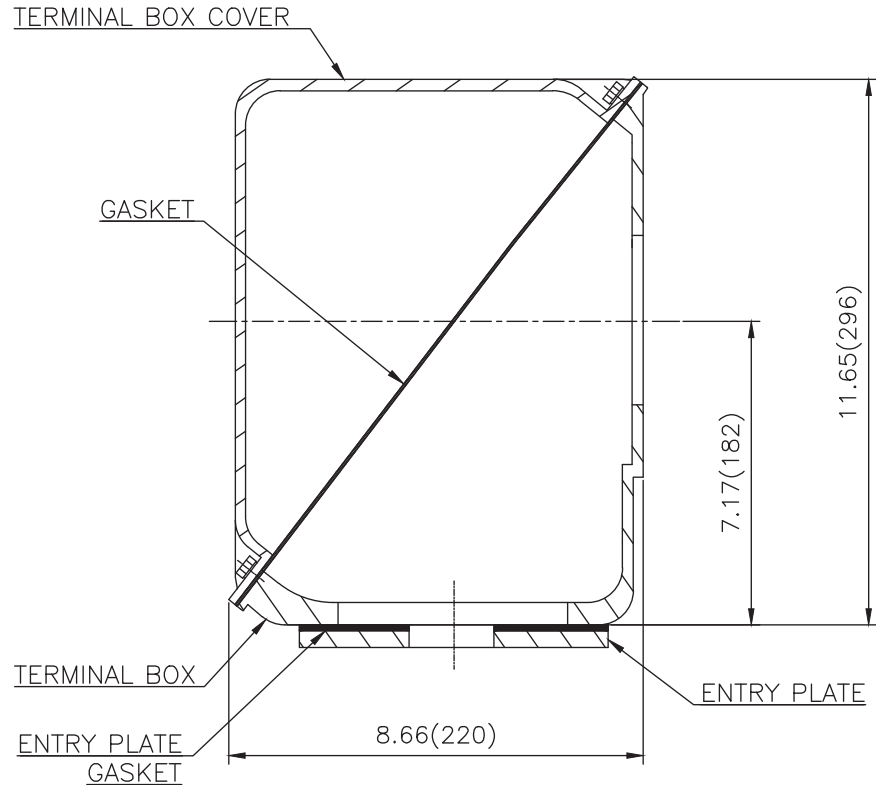
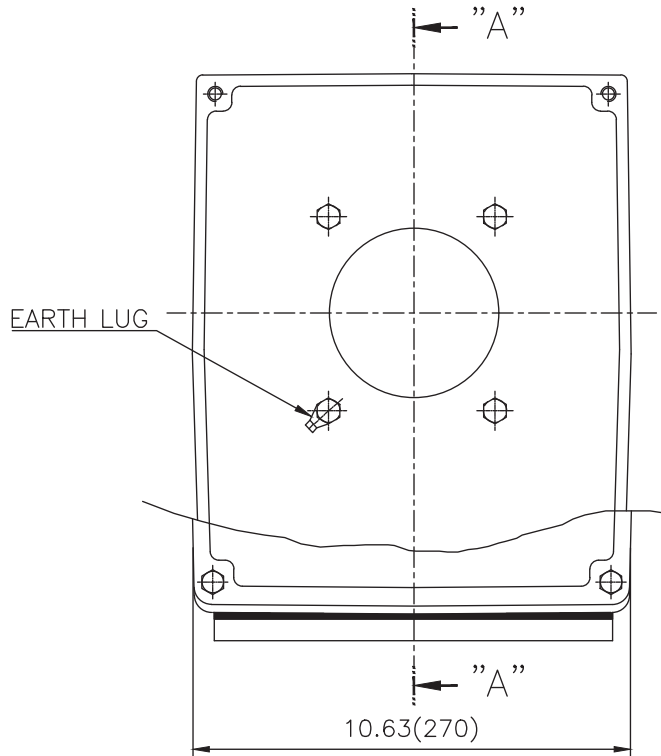

SEC. "A" - "A"

▽	50S
▽▽	12.5S
▽▽▽	3.2S
▽▽▽▽	0.4S

REV	DATE	CONTENTS	REVD BY	CHKD BY	CHKD BY	APPD BY

일반기준공차		일반재판공차	
1-4	±0.1	6-30	±0.5
4-18	±0.2	30-120	±0.8
18-63	±0.3	120-315	±1.2
63-250	±0.5	315-1000	±2.0
250-	±0.8	1000-	±3.0

Q'TY	DESCRIPTION	MATERIAL	DIMENSION	WEIGHT	PART NO.	REMARK	NO.
APPD BY	S.Y.KIM	UNIT	inch(mm)	SUBJECT	FR. 400-440 (CAST IRON)	DWG SIZE	A3 (1:1.2)
CHKD BY		SCALE	1/1.2	TITLE	MAIN TERMINAL BOX ASS'Y		
CHKD BY	R.G.KIM	PROJEC'N	3rd Angle	DATE	2023-10-19	REF. NO	Sheet No. of
DSND BY	배승희	DATE	2023-10-19	DWG NO	3M-248451	Revision No.	0

