

Customer :  
Project Name :  
Project No. :  
Revision No. :

# SPECIFICATION for INDUCTION MOTOR



0		For Bidding			
No.	DATE	DESCRIPTION	PREPARED BY	CHECKED BY	APPROVED BY



# AC INDUCTION MOTOR DATA SHEET

## IEEE841 TYPE

Catalog No.	IEEE150-12-447TCRD	Item No.	Rev. No.	[       ]
Project Name		Project No.	Quantity	sets

GENERAL SPECIFICATION		PERFORMANCE DATA			
Frame Size	447TC	Rated Output	110 kW      150 HP		
Type	PJP	Number of Poles	6		
Enclosure(Protection)	Totally Enclosed / IP55	Rotor Type	Squirrel Cage		
Method of Cooling	IC411(FC)	Starting Method*	D.O.L		
Rated Frequency	60 Hz	Rated Voltage	575 V	460 V	230 V
Number of Phases	3	Current	Full Load	135.6 A	169.5 A
Insulation Class	F		Locked-rotor**	680 %	680 %
Temp. Rise at full load (by resistance method)		Efficiency			
at 1.0 S.F	80 deg. C	50% Load		92.8 %	
Motor Location	<input type="checkbox"/> Indoor <input type="checkbox"/> Outdoor	75% Load		94.8 %	
Altitude	Less than 1,000 meter	100% Load		95.8 %	
Relative Humidity	Less than 80 %	Power Factor(p.u)			
Ambient Temp.	40 deg. C (Max.)	50% Load		0.700	
Duty Type	Continuous ( S1 )	75% Load		0.800	
Service Factor	1.15	100% Load		0.850	
Mounting	B5	Speed at Full Load	1185 r.p.m		
Bearing	Type	Anti-Friction	Torque		
	DE/N-DE	6318C3 / 6316C3	Full Load	654.0 lb.ft	
	Lubricant	Grease(Polyrex-EM)	Locked-rotor**	140 %	
External Thrust	Not applicable	Breakdown**	220 %		
Coupling Method	<input checked="" type="checkbox"/> Direct <input type="checkbox"/> V-belt	Moment of Inertia (J)			
Shaft Extension	Single	Load(Max.)	4,864.156 lb.ft2		
Terminal	Main	Motor	106.310 lb.ft2		
Box	Aux.	Sound Pressure Level (No-load & mean value at 1m from motor)			
	Location	80 dB(A)			
Application		Vibration			
Area classification	Hazardous	Permissible number of consecutive starts		Cold    3 times	
Type of Ex-Protection	Class I&II, Division 2			Hot     2 times	
Applicable Standard	IEEE841, NEMA MG1, CSA C390	Paint	Munsell No.	7.5BG6/1.5	

ACCESSORIES

SUBMITTAL DRAWING		
Outline Dimension Drawing	Motor Weight(Approx.)	
B5	LM-I1447C5PL001	2020 lb.

**REMARK**

1. Premium efficiency according to NEMA MG1
2. Inverter Duty @ 1.0 Service Factor & F Temperature rise
  - 10:1 VT (20:1 VT at 50% load)
  - 10:1 CT
  - CHP up to 1.5 times base speed, NEMA MG1 Part31
3. CSA Certification
  - Class I, Division 2, Group A, B, C & D
  - Class II, Division 2 Group E, F & G (Group E : up to 320Fr.)
4. Service Factor 1.15 and Temperature rise B are applicable under the condition of sine wave power.
5. Service Factor 1.25 is applicable to motors of 100HP or less with temperature rise F & Non-Hazardous.

Date	DSND	CHKD	CHKD	APPD
2024-07-13	S.H. Lee	I.K. Kim	R.G. Kim	S.W. Kim

[Note] Others not mentioned in this data sheet shall be in accordance with maker standard.  
 Above technical data are only design values and shall be guaranteed with tolerance of applicable standard.  
 Inspection and performance test shall be done according to maker standard, if not mentioned.  
 \* In case of Inverter-Fed Motor, performance data is based on sine wave tests. It may be different from test data of Inverter combined motor.  
 \*\* Data is based on rated voltage & frequency and is expressed as a percentage of full-load value.

1	2	3	4
REV	DATE	CONTENTS	REVD BY

4.72







150HP	6P	460V	Cat. No.	IEEE150-12-447TCRD				
Model	HLS447PR06		INS. Class	F	HD-F1	Amps	169.5	
Type	HLS	Duty	CONT	Code	G	Amb.	40°C	
Frame	447TC	Encl.	TEFC	S.F.	1.15	RPM	1185	
Bearing	Drive	6318C3		S.F.1.00 (10:1 C.T., 20:1 V.T., NEMA-MG1 Part31)		3/4 Eff.	94.8%	
	Opp.	6316C3				NEMA Design	B	
Usable at	50Hz 125HP 380V 174A 985rpm S.F.: 1.0 Eff.: 95.2% Code: G							
	50Hz 125HP 400/415V 167.1/163.2A 986/987rpm S.F.: 1.0 Eff.: 95.4/95.5% Code: H/H							
CSA Certified for	Model	LATER		Type	PJP			
	CLASS I, Div. 2, Gr. A, B, C & D CLASS I, Zone 2, Gr. IIA, IIB, & IIC	CLASS II, Div. 2, Gr. E, F & G (Gr. E : Up to 320FR)		Temp. Code (sine wave)	Frame	140~320FR	360~400FR	440FR
		Amb. 40°C	T3C (160°C)		T3B (165°C)	T3A (180°C)		
Amb. 55°C	T3A (180°C)	T3A (180°C)	T3 (200°C)					
No.	-		Date	-		Weight	2020 lb	

**IEEE Std 841-2021**

4M-135701

**MARINE DUTY IEEE45**

Made in Korea H1



2.36

APPD BY	S.Y.KIM	UNIT	INCH	SUBJECT	CSA Class I, Division2 IEEE841 (HL)	DWG SIZE
CHKD BY	I.K.KIM	SCALE	NONE			A4 ( 1:1 )
CHKD BY	R.G.KIM	PROJEC'N	3rd Angle	TITLE <b>NAMEPLATE DRAWING</b>		
DSND BY	S.H.LEE	DATE	2024.06.07			
				REF. NO	<b>4M-135701</b>	Sheet No. of
				DWG NO	<b>NP-IEEE150-12-447TCRD</b>	Revision No. <b>0</b>

Type :	PJP	
Full Load Torque :	654.0	lb.ft
Load moment of Inertia (J) :	4864.156	lb.ft <sup>2</sup>
Motor moment of Inertia (J) :	106.310	lb.ft <sup>2</sup>

110kW	150HP	6 P	60 Hz
Speed at Full Load :			1185 RPM
Rated Voltage	575V	460V	230V
Full Load Current	135.6A	169.5A	339.1A

SPEED VS TORQUE & CURRENT CURVE

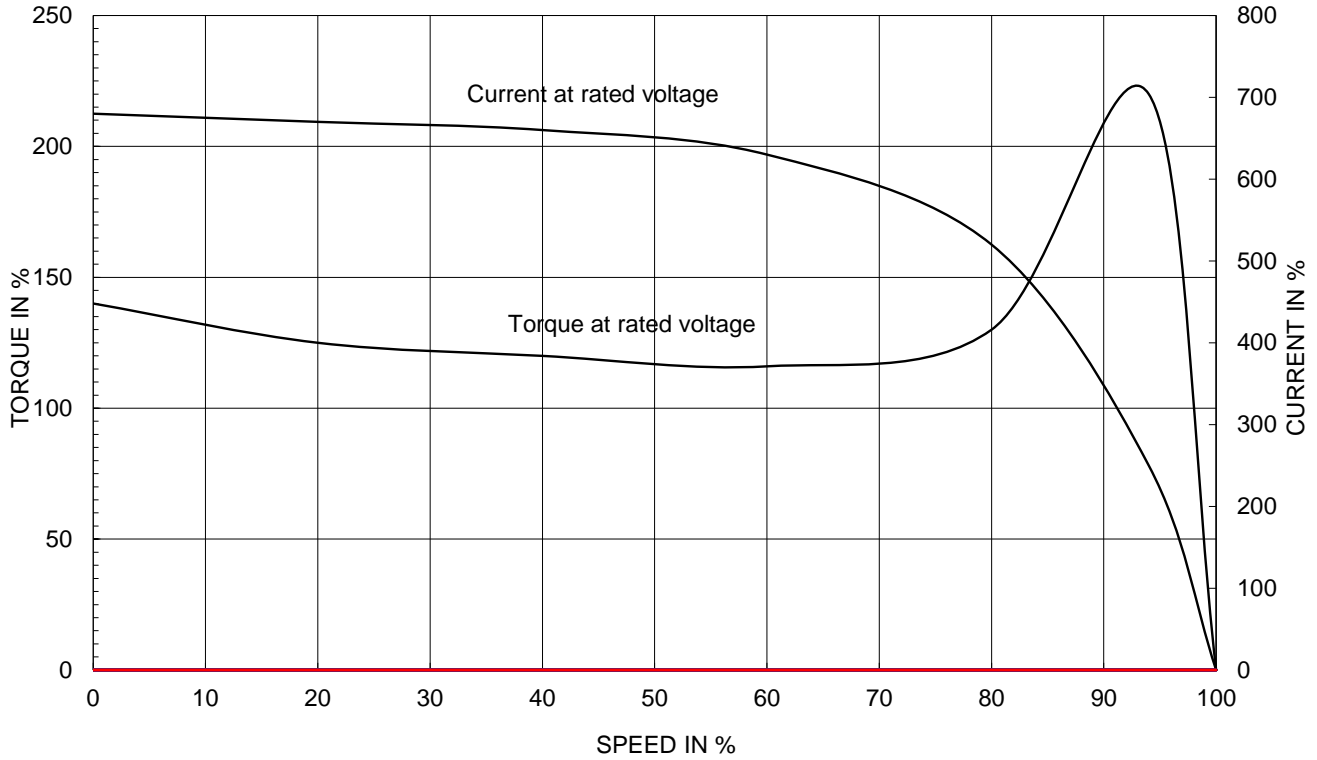

OUTPUT VS EFF., P.F & CURRENT CURVE

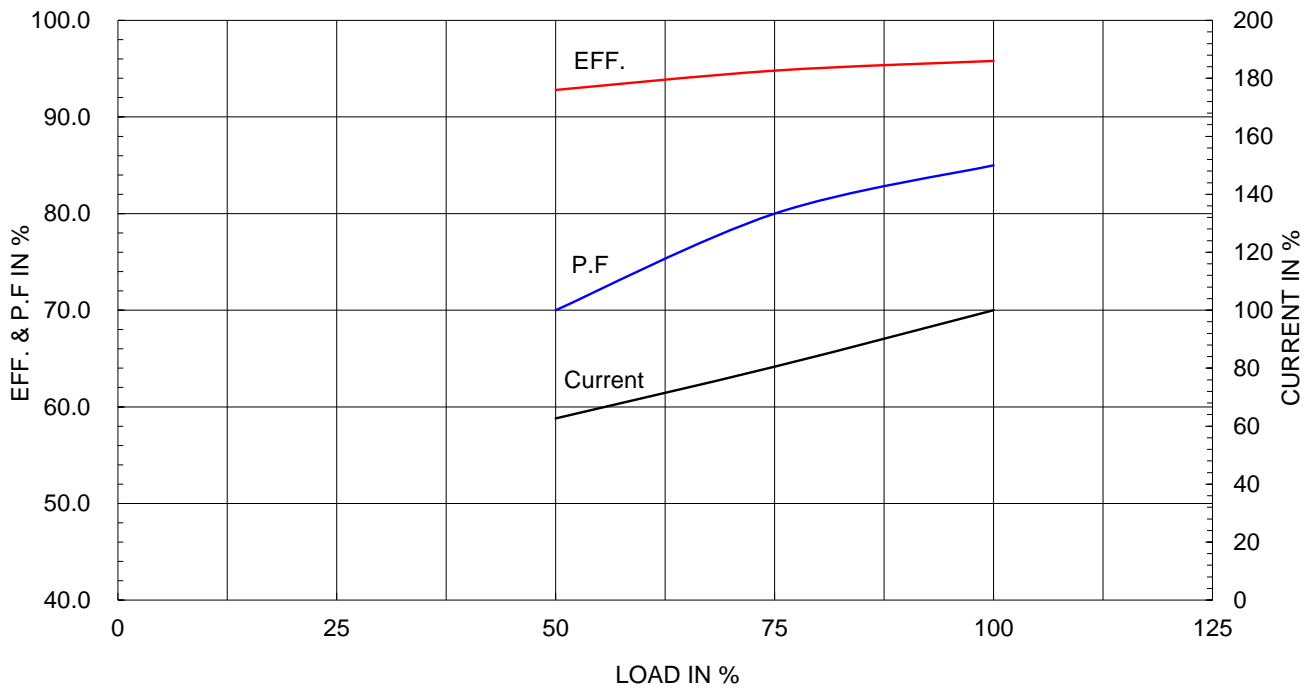

본 도면은 HD현대일렉트릭(주) 재산이며 허가없이 복사할 수 없음 (취급주의)

THIS DRAWING IS PROPRIETARY TO HYUNDAI ELECTRIC. NO PART OF THIS DRAWING MAYBE REPRODUCED WITHOUT THE PERMISSION OF HYUNDAI ELECTRIC.

▽	50S	REV	DATE	CONTENTS	REVD BY	CHKD BY	CHKD BY	APPD BY
▽▽	12.5S							
▽▽▽	3.2S							
▽▽▽▽	0.4S							

**IEEE841**

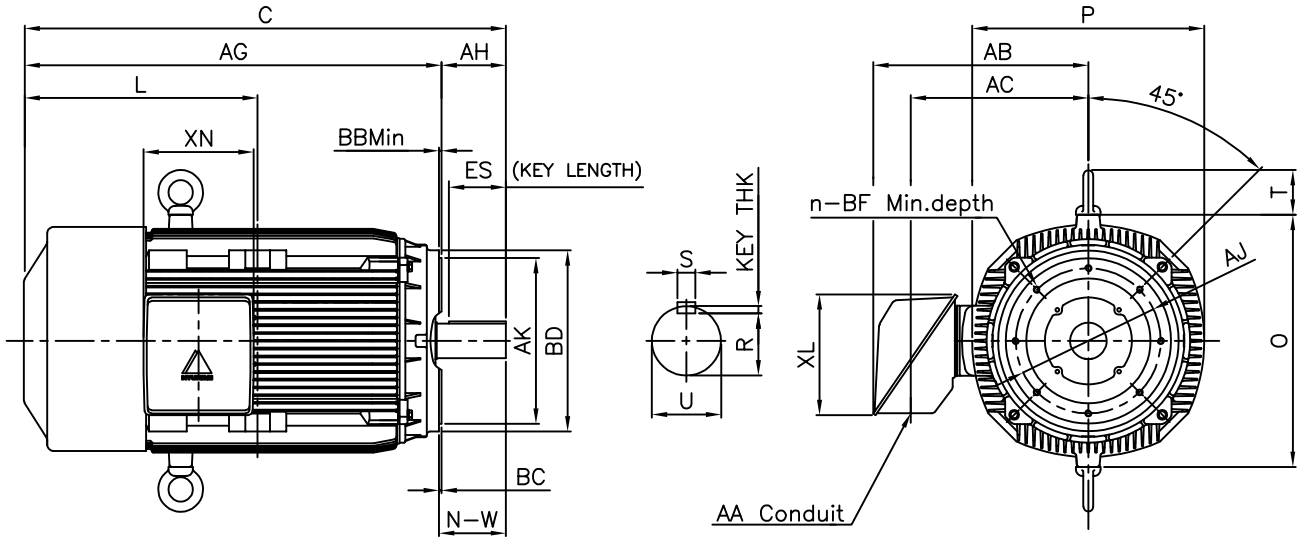

DIMENSIONS

Unit : inch

C - FLANGE									CONDUIT BOX					APPROX. WGT.(LB)
AJ	AK	BB Min	BC	BD	BF	BF depth	n	AH	AA	AB	AC	XL	XN	
14.00	16.00	0.25	0.25	17.48	5/8-11	0.94	8	8.25	3.00	23.78	18.03	16.30	13.78	2020

O V E R A L L					S H A F T				KEY	BEARING			
C	L	O	P	T	AG	U	N-W	KEYWAY			THK.	DRIVE END	OPP. DRIVE END
								R	ES	S			
50.29	24.30	24.33	22.44	4.33	42.04	3.375	8.50	2.880	6.93	0.875	0.875	6318C3	6316C3

**NOTE**

- 1.Dimension "U" tolerance : +0.000inch ~ -0.0005inch (143TC-215TC): +0.000inch ~ -0.001inch (254TC-449TC)
- 2.Dimension "R" tolerance : +0.000inch ~ - 0.015inch
- 3.Dimension "AK" tolerance : +0.000inch ~ -0.003inch (143TC-286TC): +0.000inch ~ -0.005inch (324TC-449TC)

APPD BY	S.Y.KIM	UNIT	INCH	SUBJECT	NEMA 447TC	DWG SIZE	A4 ( 1:1 )
CHKD BY	R.G.KIM	SCALE	NONE	TITLE	OUTLINE	REF. NO	350A8519AA
CHKD BY	Y.H.BAE	PROJEC'N	3각법(3rd Angle)	DWG NO		LM-11447C5PL001	Sheet No.
DSND BY	H.K.LEE	DATE	2021-04-30			Revision No.	0



# Cls. I&II, Div. 2 IEEE 841

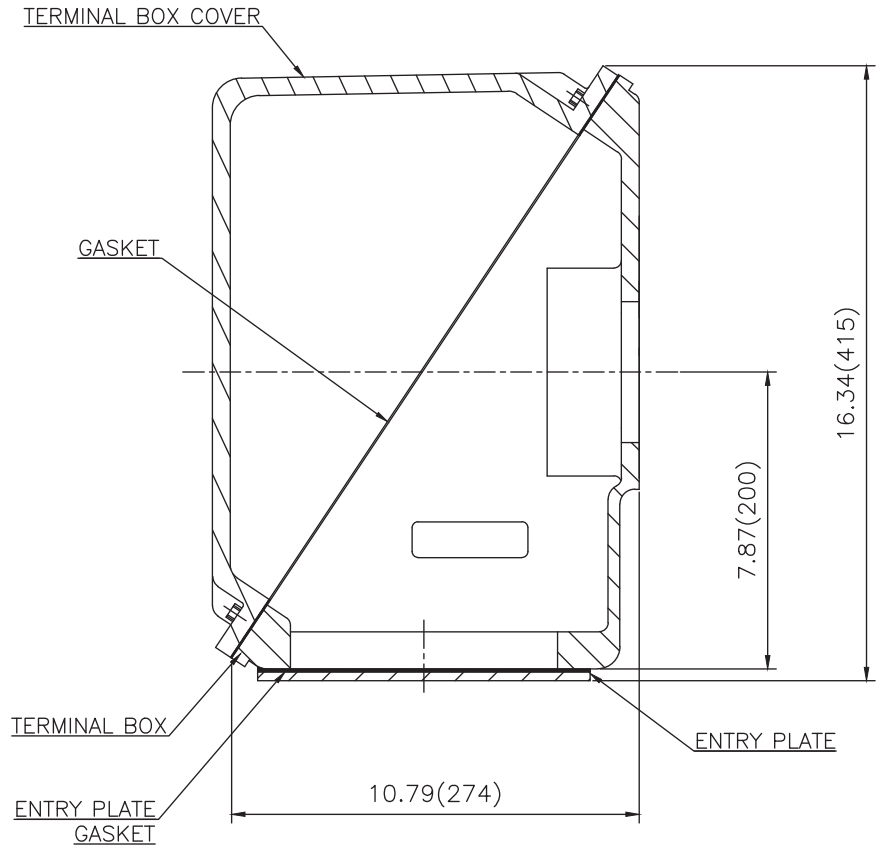
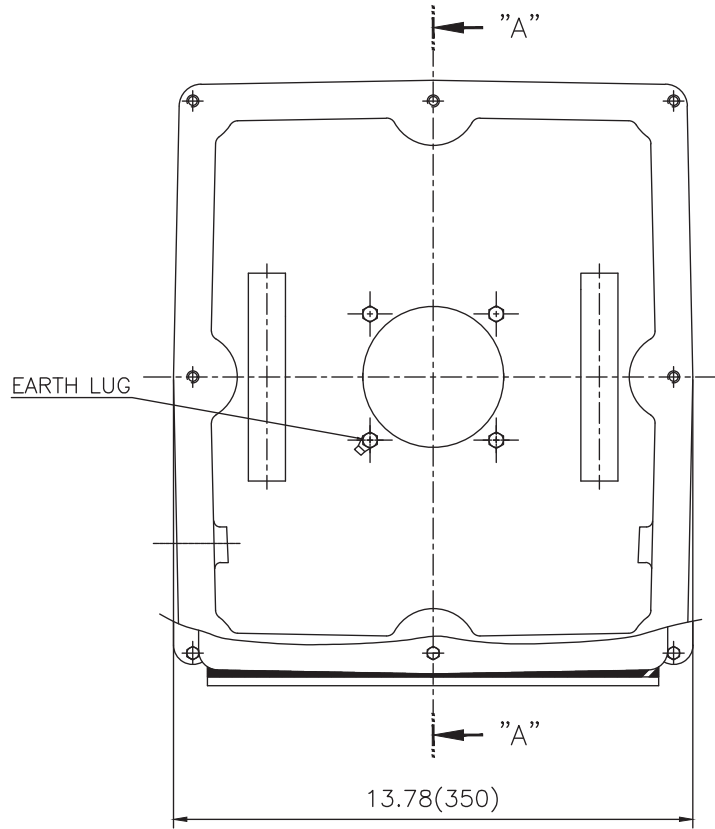

SEC. "A"-"A"

▽	50S
▽▽	12.5S
▽▽▽	3.2S
▽▽▽▽	0.4S

REV	DATE	CONTENTS	REVD BY	CHKD BY	CHKD BY	APPD BY

일반가공공차		일반기계공차	
1-4	±0.1	6-30	±0.5
4-18	±0.2	30-120	±0.8
18-63	±0.3	120-315	±1.2
63-250	±0.5	315-1000	±2.0
250-	±0.8	1000-	±3.0

Q'TY	DESCRIPTION	MATERIAL	DIMENSION	WEIGHT	PART NO.	REMARK	NO.
APPD BY	S.Y.KIM	UNIT	inch(mm)	SUBJECT	FR. L440 (CAST IRON)	DWG SIZE	A3 (1:3.5)
CHKD BY		SCALE	1/3.5	TITLE			
CHKD BY	R.G.KIM	PROJEC'N	3rd Angle	MAIN TERMINAL BOX ASS'Y			
DSND BY	배승희	DATE	2023-10-19	REF. NO		Sheet No.	of
				DWG NO	3M-248452	Revision No.	0

