

Customer :  
Project Name :  
Project No. :  
Revision No. :

# SPECIFICATION for INDUCTION MOTOR



0		For Bidding			
No.	DATE	DESCRIPTION	PREPARED BY	CHECKED BY	APPROVED BY



# AC INDUCTION MOTOR DATA SHEET

## IEEE841 TYPE

Catalog No.	IEEE15-36-254TC	Item No.	Rev. No. [      ]
Project Name		Project No.	Quantity                      sets

GENERAL SPECIFICATION		PERFORMANCE DATA			
Frame Size	254TC	Rated Output	11 kW		15 HP
Type	PJP	Number of Poles	2		
Enclosure(Protection)	Totally Enclosed / IP55	Rotor Type	Squirrel Cage		
Method of Cooling	IC411(FC)	Starting Method*	D.O.L		
Rated Frequency	60 Hz	Rated Voltage	575 V	460 V	230 V
Number of Phases	3	Current	Full Load	13.8 A	17.2 A
Insulation Class	F		Locked-rotor**	710 %	710 %
Temp. Rise at full load (by resistance method)		Efficiency			
at 1.0 S.F	80 deg. C	50% Load		88.0 %	
Motor Location	<input type="checkbox"/> Indoor <input type="checkbox"/> Outdoor	75% Load		90.0 %	
Altitude	Less than 1,000 meter	100% Load		91.0 %	
Relative Humidity	Less than 80 %	Power Factor(p.u)			
Ambient Temp.	40 deg. C (Max.)	50% Load		0.730	
Duty Type	Continuous ( S1 )	75% Load		0.830	
Service Factor	1.15	100% Load		0.880	
Mounting	B35	Speed at Full Load	3550 r.p.m		
Bearing	Type	Anti-Friction	Torque		
	DE/N-DE	6309ZC3 / 6309ZC3	Full Load	21.8 lb.ft	
	Lubricant	Grease(Polyrex-EM)	Locked-rotor**	150 %	
External Thrust	Not applicable	Breakdown**	250 %		
Coupling Method	<input checked="" type="checkbox"/> Direct <input type="checkbox"/> V-belt	Moment of Inertia (J)			
Shaft Extension	Single	Load(Max.)	15.597 lb.ft2		
Terminal Box	Main	Cast Iron	Motor	0.926 lb.ft2	
	Aux.	No	Sound Pressure Level (No-load & mean value at 1m from motor)		
Location	Refer to Outline Drawing			79 dB(A)	
Application		Vibration		3.8 mm/sec (peak)	
Area classification	Hazardous	Permissible number of consecutive starts	Cold	3 times	
Type of Ex-Protection	Class I&II, Division 2		Hot	2 times	
Applicable Standard	IEEE841, NEMA MG1, CSA C390	Paint	Munsell No.	7.5BG6/1.5	

ACCESSORIES

SUBMITTAL DRAWING		
Outline Dimension Drawing	Motor Weight(Approx.)	
B35	LM-I1254C4PL001	260 lb.

SPARE PARTS

REMARK				
<ol style="list-style-type: none"> <li>1. Premium efficiency according to NEMA MG1</li> <li>2. Inverter Duty @ 1.0 Service Factor &amp; F Temperature rise               <ul style="list-style-type: none"> <li>- 10:1 VT (20:1 VT at 50% load)</li> <li>- 10:1 CT</li> <li>- CHP up to 1.5 times base speed, NEMA MG1 Part31</li> </ul> </li> <li>3. CSA Certification               <ul style="list-style-type: none"> <li>- Class I, Division 2, Group A, B, C &amp; D</li> <li>- Class II, Division 2 Group E, F &amp; G (Group E : up to 320Fr.)</li> </ul> </li> <li>4. Service Factor 1.15 and Temperature rise B are applicable under the condition of sine wave power.</li> <li>5. Service Factor 1.25 is applicable to motors of 100HP or less with temperature rise F &amp; Non-Hazardous.</li> </ol>				
Date	DSND	CHKD	CHKD	APPD
2024-07-13	S.H. Lee	I.K. Kim	R.G. Kim	S.W. Kim

[Note] Others not mentioned in this data sheet shall be in accordance with maker standard.  
 Above technical data are only design values and shall be guaranteed with tolerance of applicable standard.  
 Inspection and performance test shall be done according to maker standard, if not mentioned.  
 \* In case of Inverter-Fed Motor, performance data is based on sine wave tests. It may be different from test data of Inverter combined motor.  
 \*\* Data is based on rated voltage & frequency and is expressed as a percentage of full-load value.



Type :	PJP
Full Load Torque :	21.8 lb.ft
Load moment of Inertia (J) :	15.597 lb.ft2
Motor moment of Inertia (J) :	0.926 lb.ft2

11kW 15HP	2 P	60 Hz
Speed at Full Load :		3550 RPM
Rated Voltage	575V	460V 230V
Full Load Current	13.8A	17.2A 34.5A

SPEED VS TORQUE & CURRENT CURVE

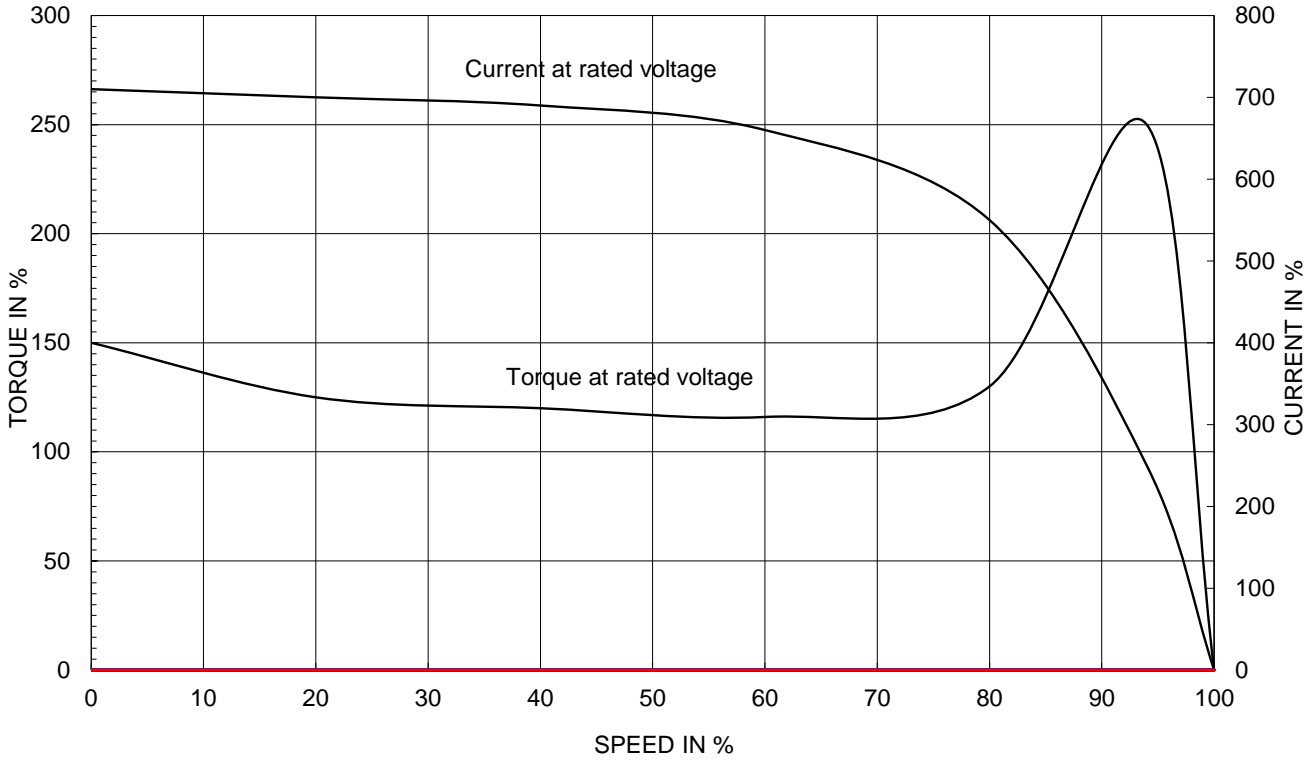

OUTPUT VS EFF., P.F & CURRENT CURVE

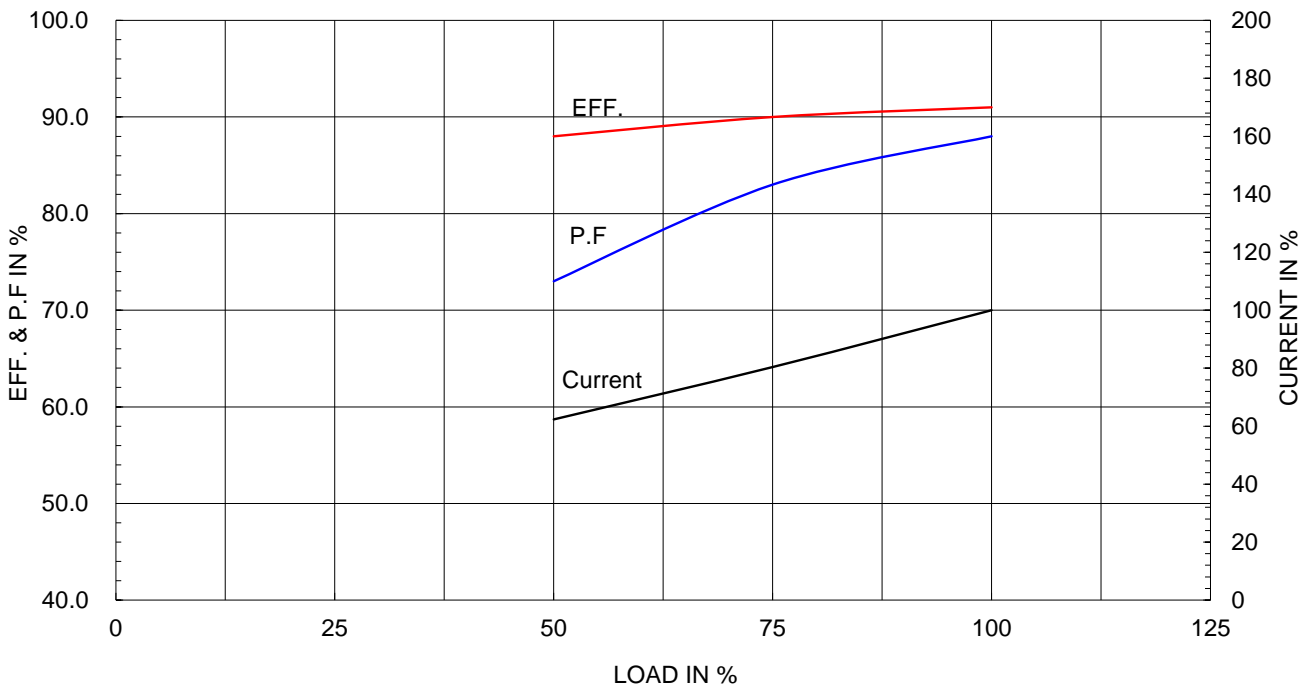

본 도면은 HD현대일렉트릭(주) 재산이며  
허기없이 복사할 수 없음 (취급유의)

THIS DRAWING IS PROPRIETARY TO HYUNDAI ELECTRIC. NO PART OF THIS DRAWING  
MAYBE REPRODUCED WITHOUT THE PERMISSION OF HYUNDAI ELECTRIC.

▽	50S	REV	DATE	CONTENTS	REVD BY	CHKD BY	CHKD BY	APPD BY
▽▽	12.5S							
▽▽▽	3.2S							
▽▽▽▽	0.4S							

**IEEE841**

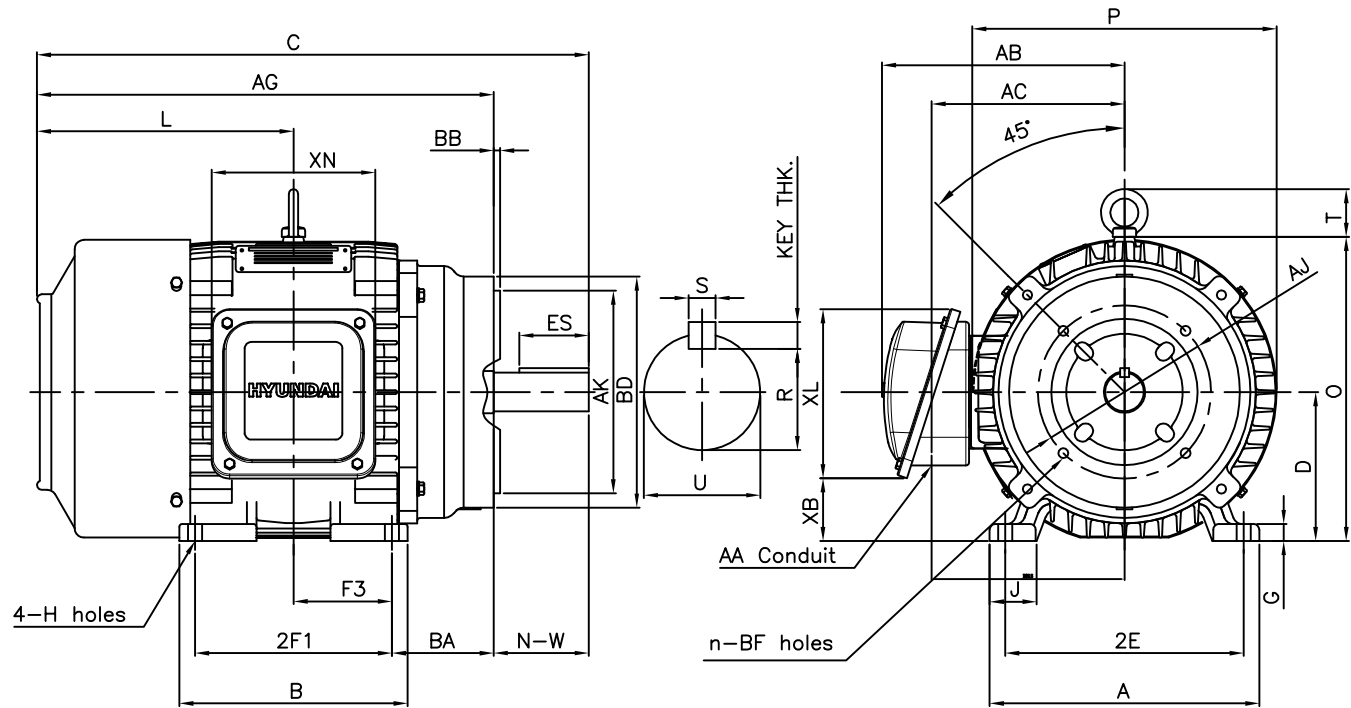

DIMENSIONS

Unit : inch

F L A N G E						M O U N T I N G								
AJ	AK	BD	BB	BF	n	A	B	2E	2F1	2F2	F3	G	J	H
7.25	8.50	9.68	0.25	1/2-13	4	11.30	9.56	10.00	8.25	-	4.13	0.72	1.93	0.53

C O N D U I T B O X						O V E R A L L								APPROX. WGT.(LB)
AA	AB	AC	XB	XL	XN	AG	BA	C	D	L	O	P	T	
1.25	11.85	8.46	2.64	8.43	8.19	19.13	4.25	23.13	6.25	10.75	12.75	12.76	2.01	260

S H A F T					KEY THK.	B E A R I N G	
U	N-W	KEYWAY				DRIVE END	OPP. DRIVE END
		R	ES	S			
1.625	4.00	1.416	2.91	0.375	0.375	6309ZC3	6309ZC3

**NOTE**

- 1.Dimension "D" tolerance : +0.00inch - 0.03inch
- 2.Dimension "U" tolerance : +0.000inch - 0.0005inch
- 3.Dimension "R" tolerance : +0.000inch - 0.015inch

APPD BY	S.Y.KIM	UNIT	INCH	SUBJECT	NEMA 254TC(KIT)	DWG SIZE	A4 ( 1:1 )		
CHKD BY	R.G.KIM	SCALE	NONE	TITLE	OUTLINE	REF. NO	350A8307AA		
CHKD BY	Y.H.BAE	PROJEC'N	3각법(3rd Angle)					Sheet No.	of
DSND BY	H.K.LEE	DATE	2021-05-06					DWG NO	LM-I1254C4PL001



# Cls. I&II, Div. 2 IEEE 841



▽	50S
▽▽	12.5S
▽▽▽	3.2S
▽▽▽▽	0.4S

REV	DATE	CONTENTS	REVD BY	CHKD BY	CHKD BY	APPD BY

일반가공공차		일반제관공차	
1-4	±0.1	6-30	±0.5
4-18	±0.2	30-120	±0.8
18-63	±0.3	120-315	±1.2
63-250	±0.5	315-1000	±2.0
250-	±0.8	1000-	±3.0

Q'TY	DESCRIPTION	MATERIAL	DIMENSION	WEIGHT	PART NO.	REMARK	NO.
APPD BY	S.Y.KIM	UNIT	inch(mm)	SUBJECT	FR. 250-280 (CAST IRON)	DWG SIZE	
CHKD BY		SCALE	1/2	TITLE	TERMINAL BOX ASS'Y		
CHKD BY	R.G.KIM	PROJEC'N	3rd Angle	DATE	2023-10-19		
DSND BY	배승희	DATE					
REF. NO						Sheet No.	of
DWG NO	3M-248458					Revision No.	0

