

Customer :
Project Name :
Project No. :
Revision No. :

SPECIFICATION for INDUCTION MOTOR



0		For Bidding			
No.	DATE	DESCRIPTION	PREPARED BY	CHECKED BY	APPROVED BY



AC INDUCTION MOTOR DATA SHEET

IEEE841 TYPE

Catalog No.	IEEE15-18-254T	Item No.	Rev. No.	[]
Project Name		Project No.	Quantity	sets

GENERAL SPECIFICATION		PERFORMANCE DATA				
Frame Size	254T	Rated Output	11 kW 15 HP			
Type	PJP	Number of Poles	4			
Enclosure(Protection)	Totally Enclosed / IP55	Rotor Type	Squirrel Cage			
Method of Cooling	IC411(FC)	Starting Method*	D.O.L			
Rated Frequency	60 Hz	Rated Voltage	575 V	460 V	230 V	
Number of Phases	3	Current	Full Load	14.6 A	18.2 A 36.4 A	
Insulation Class	F		Locked-rotor**	750 %	750 % 750 %	
Temp. Rise at full load (by resistance method)		Efficiency				
at 1.0 S.F	80 deg. C	50% Load		89.4 %		
Motor Location	<input type="checkbox"/> Indoor <input type="checkbox"/> Outdoor	75% Load		91.4 %		
Altitude	Less than 1,000 meter	100% Load		92.4 %		
Relative Humidity	Less than 80 %	Power Factor(p.u)				
Ambient Temp.	40 deg. C (Max.)	50% Load		0.670		
Duty Type	Continuous (S1)	75% Load		0.770		
Service Factor	1.15	100% Load		0.820		
Mounting	B3	Speed at Full Load		1775 r.p.m		
Bearing	Type	Anti-Friction				
	DE/N-DE	6309ZC3 / 6309ZC3				
	Lubricant	Grease(Polyrex-EM)				
External Thrust	Not applicable					
Coupling Method	<input checked="" type="checkbox"/> Direct <input type="checkbox"/> V-belt	Torque				
Shaft Extension	Single	Full Load		43.7 lb.ft		
Terminal Box	Main	Locked-rotor**		200 %		
	Aux.	Breakdown**		240 %		
Location	Refer to Outline Drawing	Moment of Inertia (J)				
Application		Load(Max.)		88.098 lb.ft2		
Area classification	Hazardous	Motor		2.136 lb.ft2		
Type of Ex-Protection	Class I&II, Division 2	Sound Pressure Level (No-load & mean value at 1m from motor)				
Applicable Standard	IEEE841, NEMA MG1, CSA C390			74 dB(A)		
ACCESSORIES		Vibration				3.8 mm/sec (peak)
		Permissible number of consecutive starts		Cold	3 times	
				Hot	2 times	
		Paint	Munsell No.	7.5BG6/1.5		
SPARE PARTS		SUBMITTAL DRAWING				
		Outline Dimension Drawing		Motor Weight(Approx.)		
		B3	LM-I1254B3PL001	260 lb.		
REMARK		1. Premium efficiency according to NEMA MG1				
		2. Inverter Duty @ 1.0 Service Factor & F Temperature rise				
		- 10:1 VT (20:1 VT at 50% load)				
		- 10:1 CT				
		- CHP up to 1.5 times base speed, NEMA MG1 Part31				
		3. CSA Certification				
		- Class I, Division 2, Group A, B, C & D				
		- Class II, Division 2 Group E, F & G (Group E : up to 320Fr.)				
		4. Service Factor 1.15 and Temperature rise B are applicable under the condition of sine wave power.				
		5. Service Factor 1.25 is applicable to motors of 100HP or less with temperature rise F & Non-Hazardous.				
		Date	DSND	CHKD	CHKD APPD	
		2024-07-13	S.H. Lee	I.K. Kim	R.G. Kim S.W. Kim	

[Note] Others not mentioned in this data sheet shall be in accordance with maker standard.
 Above technical data are only design values and shall be guaranteed with tolerance of applicable standard.
 Inspection and performance test shall be done according to maker standard, if not mentioned.
 * In case of Inverter-Fed Motor, performance data is based on sine wave tests. It may be different from test data of Inverter combined motor.
 ** Data is based on rated voltage & frequency and is expressed as a percentage of full-load value.

1	2	3	4
REV	DATE	CONTENTS	REVD BY

4.72

CROWN TRITON
Premium Efficiency AC 3 Phase Motor

15HP	4P	460V	Cat. No.	IEEE15-18-254T				
Model	HLS254SR23		INS. Class	F	HD-F1	Amps	18.2	
Type	HLS	Duty	CONT	Code	J	Amb.	40°C	
Frame	254T	Encl.	TEFC	S.F.	1.15	RPM	1775	
Bearing	Drive	6309ZC3		S.F.1.00 (10:1 C.T., 20:1 V.T., NEMA-MG1 Part31)		3/4 Eff.	91.4%	
	Opp.	6309ZC3				NEMA Design	B Torque	
Usable at	50Hz 10HP 380V 18A 1475rpm S.F.: 1.0 Eff.: 88.7% Code: L							
	50Hz 10HP 400/415V 17.9/18.1A 1480/1480rpm S.F.: 1.0 Eff.: 88.7/88.7% Code: L/L							
CSA Certified for	Model	LATER		Type	PJP			
	CLASS I, Div. 2, Gr. A, B, C & D CLASS I, Zone 2, Gr. IIA, IIB, & IIC	CLASS II, Div. 2, Gr. E, F & G (Gr. E : Up to 320FR)		Temp. Code (sine wave)	Frame	140~320FR	360~400FR	440FR
		Amb. 40°C	T3C (160°C)		T3B (165°C)	T3A (180°C)		
Amb. 55°C	T3A (180°C)	T3A (180°C)	T3 (200°C)					
No.	-		Date	-		Weight	260 lb	

IEEE Std 841-2021

4M-135701

MARINE DUTY IEEE45

Made in Korea H1

2.36

APPD BY	S.Y.KIM	UNIT	INCH	SUBJECT	CSA Class I, Division2 IEEE841 (HL)	DWG SIZE
CHKD BY	I.K.KIM	SCALE	NONE			A4 (1:1)
CHKD BY	R.G.KIM	PROJEC'N	3rd Angle	TITLE NAMEPLATE DRAWING		
DSND BY	S.H.LEE	DATE	2024.06.07			
				REF. NO	4M-135701	Sheet No. of
				DWG NO	NP-IEEE15-18-254T	Revision No. 0

Type :	PJP
Full Load Torque :	43.7 lb.ft
Load moment of Inertia (J) :	88.098 lb.ft2
Motor moment of Inertia (J) :	2.136 lb.ft2

11kW 15HP	4 P	60 Hz
Speed at Full Load :		1775 RPM
Rated Voltage	575V	460V 230V
Full Load Current	14.6A	18.2A 36.4A

SPEED VS TORQUE & CURRENT CURVE

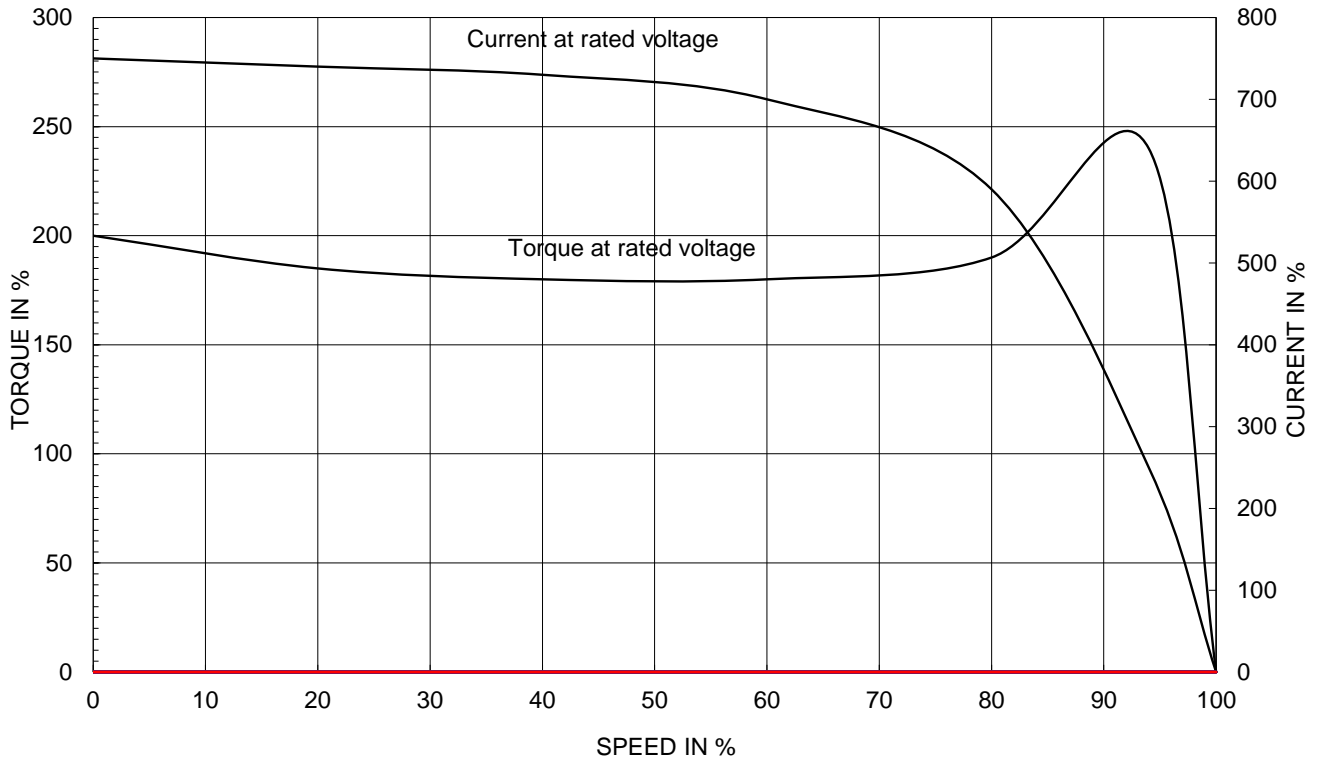

OUTPUT VS EFF., P.F & CURRENT CURVE

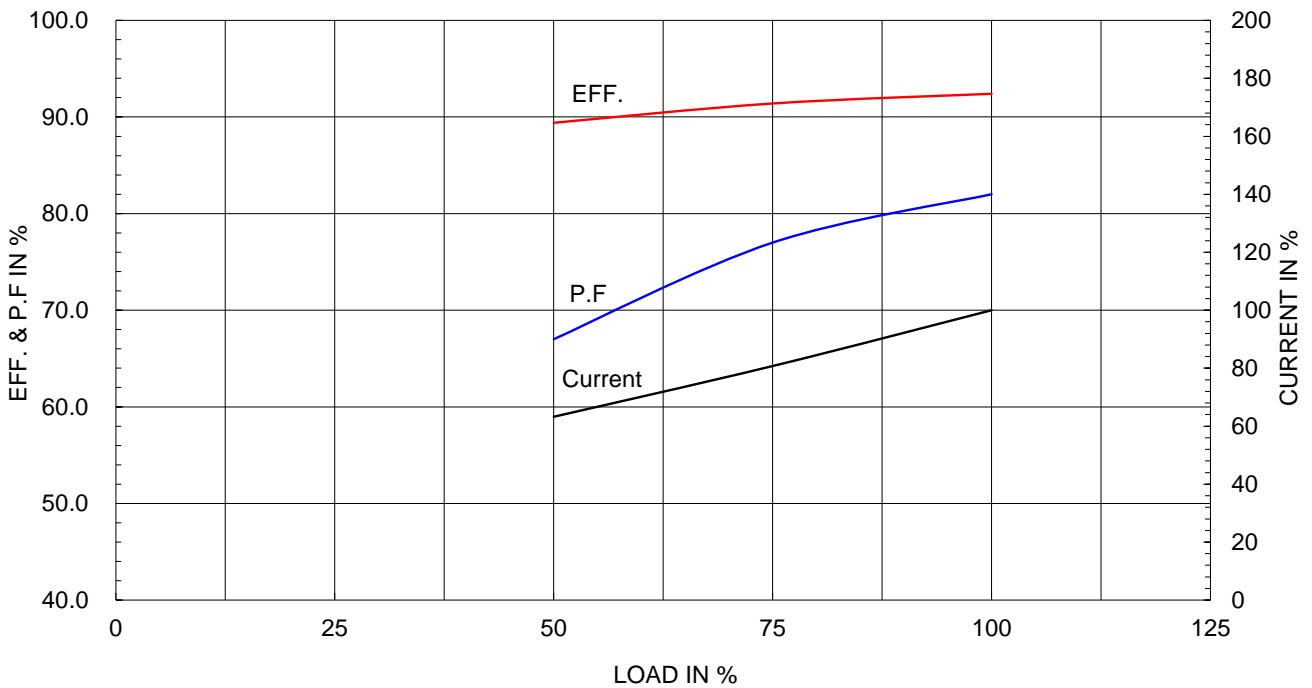

본 도면은 HD현대일렉트릭(주) 재산이며 허가없이 복사할 수 없음 (취급유의)

THIS DRAWING IS PROPRIETARY TO HYUNDAI ELECTRIC. NO PART OF THIS DRAWING MAYBE REPRODUCED WITHOUT THE PERMISSION OF HYUNDAI ELECTRIC.

▽	50S	REV	DATE	CONTENTS	REVD BY	CHKD BY	CHKD BY	APPD BY
▽▽	12.5S							
▽▽▽	3.2S							
▽▽▽▽	0.4S							

IEEE841

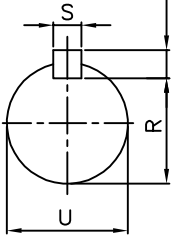
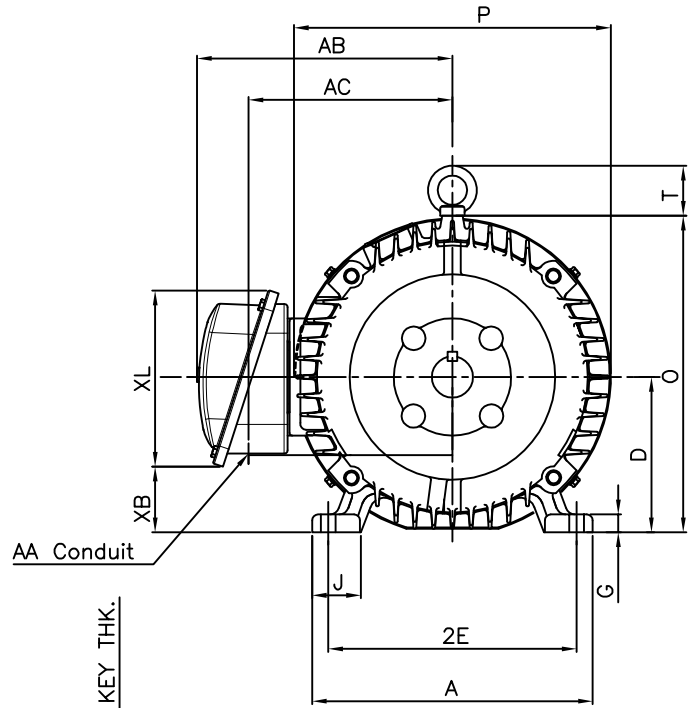
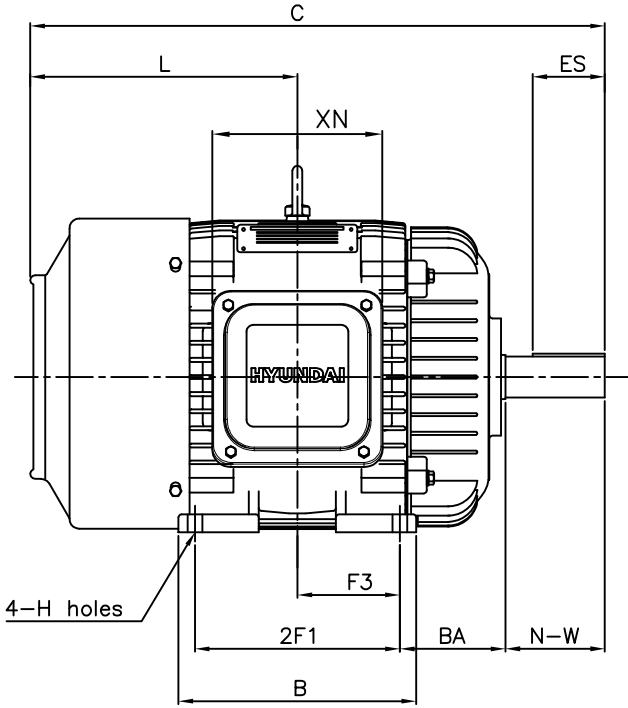

DIMENSIONS

Unit : inch

M O U N T I N G									C O N D U I T B O X						APPROX. WGT.(LB)
A	B	2E	2F1	2F2	F3	G	J	H	AA	AB	AC	XB	XL	XN	
11.30	9.56	10.00	8.25	-	4.13	0.72	1.93	0.53	1.25	11.85	8.46	2.64	8.43	8.19	260

O V E R A L L							S H A F T					KEY THK.	B E A R I N G	
BA	C	D	L	O	P	T	U	N-W	KEYWAY				DRIVE END	OPP. DRIVE END
									R	ES	S			
4.25	24.93	6.25	11.68	12.75	12.76	2.01	1.625	4.00	1.416	2.91	0.375	0.375	6309ZC3	6309ZC3

NOTE

- 1.Dimension "D" tolerance : +0.00inch - 0.03inch
- 2.Dimension "U" tolerance : +0.000inch - 0.001inch
- 3.Dimension "R" tolerance : +0.000inch - 0.015inch

APPD BY	S.Y.KIM	UNIT	INCH	SUBJECT	NEMA 254T		DWG SIZE
CHKD BY	R.G.KIM	SCALE	NONE	TITLE	OUTLINE		A4 (1:1)
CHKD BY	Y.H.BAE	PROJEC'N	3각법(3rd Angle)				
DSND BY	H.K.LEE	DATE	2021-04-30				
REF. NO	350A8107AA		Sheet No.	of			
DWG NO	LM-I1254B3PL001		Revision No.	0			



Cls. I&II, Div. 2
IEEE 841



SEC. "A" - "A"

▽	50S
▽▽	12.5S
▽▽▽	3.2S
▽▽▽▽	0.4S

Q'TY	DESCRIPTION	MATERIAL	DIMENSION	WEIGHT	PART NO.	REMARK	NO.
APPD BY	S.Y.KIM	UNIT	inch(mm)	SUBJECT	FR. 250-280 (CAST IRON)	DWG SIZE	
CHKD BY		SCALE	1/2	TITLE		A3 (1:2)	
CHKD BY	R.G.KIM	PROJEC'N	3rd Angle	TERMINAL BOX ASS'Y			
DSND BY	배승희	DATE	2023-10-19	REF. NO		Sheet No.	of
				DWG NO	3M-248458	Revision No.	0

일반가공공차		일반제관공차	
1-4	±0.1	6-30	±0.5
4-18	±0.2	30-120	±0.8
18-63	±0.3	120-315	±1.2
63-250	±0.5	315-1000	±2.0
250-	±0.8	1000-	±3.0



REV	DATE	CONTENTS	REVD BY	CHKD BY	CHKD BY	APPD BY
1						
2						
3						
4						