

Customer :
Project Name :
Project No. :
Revision No. :

SPECIFICATION for INDUCTION MOTOR



0		For Bidding			
No.	DATE	DESCRIPTION	PREPARED BY	CHECKED BY	APPROVED BY



AC INDUCTION MOTOR DATA SHEET

IEEE841 TYPE

Catalog No.	IEEE1.5-36-143TCRD	Item No.	Rev. No. []
Project Name		Project No.	Quantity sets

GENERAL SPECIFICATION		PERFORMANCE DATA			
Frame Size	143TC	Rated Output	1.1 kW 1.5 HP		
Type	PJP	Number of Poles	2		
Enclosure(Protection)	Totally Enclosed / IP55	Rotor Type	Squirrel Cage		
Method of Cooling	IC411(FC)	Starting Method*	D.O.L		
Rated Frequency	60 Hz	Rated Voltage	575 V	460 V	230 V
Number of Phases	3	Current	Full Load	1.57 A	1.96 A
Insulation Class	F		Locked-rotor**	1000 %	1,000 %
Temp. Rise at full load (by resistance method)		Efficiency			
at 1.0 S.F	80 deg. C	50% Load		81.0 %	
Motor Location	<input type="checkbox"/> Indoor <input type="checkbox"/> Outdoor	75% Load		83.0 %	
Altitude	Less than 1,000 meter	100% Load		84.0 %	
Relative Humidity	Less than 80 %	Power Factor(p.u)			
Ambient Temp.	40 deg. C (Max.)	50% Load		0.690	
Duty Type	Continuous (S1)	75% Load		0.790	
Service Factor	1.15	100% Load		0.840	
Mounting	B5	Speed at Full Load	3485 r.p.m		
Bearing	Type	Anti-Friction	Torque		
	DE/N-DE	6205ZC3 / 6204ZC3	Full Load	2.2 lb.ft	
	Lubricant	Grease(Polyrex-EM)	Locked-rotor**	185 %	
External Thrust	Not applicable	Breakdown**	260 %		
Coupling Method	<input checked="" type="checkbox"/> Direct <input type="checkbox"/> V-belt	Moment of Inertia (J)			
Shaft Extension	Single	Load(Max.)	2.119 lb.ft2		
Terminal Box	Main	Cast Iron	Motor	0.033 lb.ft2	
	Aux.	No	Sound Pressure Level (No-load & mean value at 1m from motor)		
Location	Refer to Outline Drawing			69 dB(A)	
Application		Vibration		3.8 mm/sec (peak)	
Area classification	Hazardous	Permissible number of consecutive starts	Cold	3 times	
Type of Ex-Protection	Class I&II, Division 2		Hot	2 times	
Applicable Standard	IEEE841, NEMA MG1, CSA C390	Paint	Munsell No.	7.5BG6/1.5	

ACCESSORIES

SUBMITTAL DRAWING		
Outline Dimension Drawing	Motor Weight(Approx.)	
B5	LM-II143C5PL001	53 lb.

SPARE PARTS

REMARK				
1. Premium efficiency according to NEMA MG1 2. Inverter Duty @ 1.0 Service Factor & F Temperature rise -. 10:1 VT (20:1 VT at 50% load) -. 10:1 CT -. CHP up to 1.5 times base speed, NEMA MG1 Part31 3. CSA Certification -. Class I, Division 2, Group A, B, C & D -. Class II, Division 2 Group E, F & G (Group E : up to 320Fr.) 4. Service Factor 1.15 and Temperature rise B are applicable under the condition of sine wave power. 5. Service Factor 1.25 is applicable to motors of 100HP or less with temperature rise F & Non-Hazardous.				
Date	DSND	CHKD	CHKD	APPD
2024-07-13	S.H. Lee	I.K. Kim	R.G. Kim	S.W. Kim

[Note] Others not mentioned in this data sheet shall be in accordance with maker standard.
 Above technical data are only design values and shall be guaranteed with tolerance of applicable standard.
 Inspection and performance test shall be done according to maker standard, if not mentioned.
 * In case of Inverter-Fed Motor, performance data is based on sine wave tests. It may be different from test data of Inverter combined motor.
 ** Data is based on rated voltage & frequency and is expressed as a percentage of full-load value.

본 도면은 HD현대일렉트릭(주) 재산이며 허가없이 복사할 수 없음 (취급주의)

THIS DRAWING IS PROPRIETARY TO HYUNDAI ELECTRIC. NO PART OF THIS DRAWING MAYBE REPRODUCED WITHOUT THE PERMISSION OF HYUNDAI ELECTRIC.

1	2	3	4
REV	DATE	CONTENTS	REVD BY

4.02

1.81

CROWN TRITON
Premium Efficiency AC 3 Phase Motor

1.5HP	2P	460V	Cat. No.	IEEE1.5-36-143TCRD			
Model	HLS143PL138		INS. Class	F	HD-F1	Amps	1.96
Type	HLS	Duty	CONT	Code	L	Hertz	60Hz
Frame	143TC	Encl.	TEFC	RPM	3485	Amb.	40°C
<input type="checkbox"/>	Drive	6205ZC3		S.F.	1.15	NEMA Design	B
	Opp.	6204ZC3		S.F.1.00(10:1 C.T., 20:1 V.T., NEMA-MG1 Part31)			<input type="checkbox"/>
Usable at	50Hz 1HP 380V 1.9A 2900rpm S.F.: 1.0 Eff.: 77.4% Code: L						
	50Hz 1HP 400/415V 1.9/1.8A 2910/2915rpm S.F.: 1.0 Eff.: 77.4/77.4% Code: L/L						
CSA Certified for	Model	LATER		Type	PJP	Temp. Code	Frame
	CLASS I, Div 2, Gr A, B, C & D		CLASS II, Div 2, Gr E, F & G		(sine wave)	Amb.40°C	140~320FR
	CLASS I, Zone 2, Gr IIA, IIB & IIC					Amb.55°C	T3C (160°C)
No.	-		Date	-		Weight	53 lb

IEEE Std 841-2021

NP249A7178RCP1

MARINE DUTY IEEE45

Made in Korea H3

APPD BY	S.Y.KIM	UNIT	INCH	SUBJECT	CSA Class I, Division2 IEEE841 (HL)	DWG SIZE
CHKD BY	I.K.KIM	SCALE	NONE	TITLE	NAMEPLATE DRAWING	A4 (1:1)
CHKD BY	R.G.KIM	PROJEC'N	3rd Angle			
DSND BY	S.H.LEE	DATE	2024.06.07			
				REF. NO	NP249A7178R	Sheet No. of
				DWG NO	NP-IEEE1.5-36-143TCRD	Revision No. 0

Type :	PJP
Full Load Torque :	2.2 lb.ft
Load moment of Inertia (J) :	2.119 lb.ft2
Motor moment of Inertia (J) :	0.033 lb.ft2

1.1kW 1.5HP	2 P	60 Hz
Speed at Full Load :		3485 RPM
Rated Voltage	575V	460V 230V
Full Load Current	1.6A	2.0A 3.9A

SPEED VS TORQUE & CURRENT CURVE

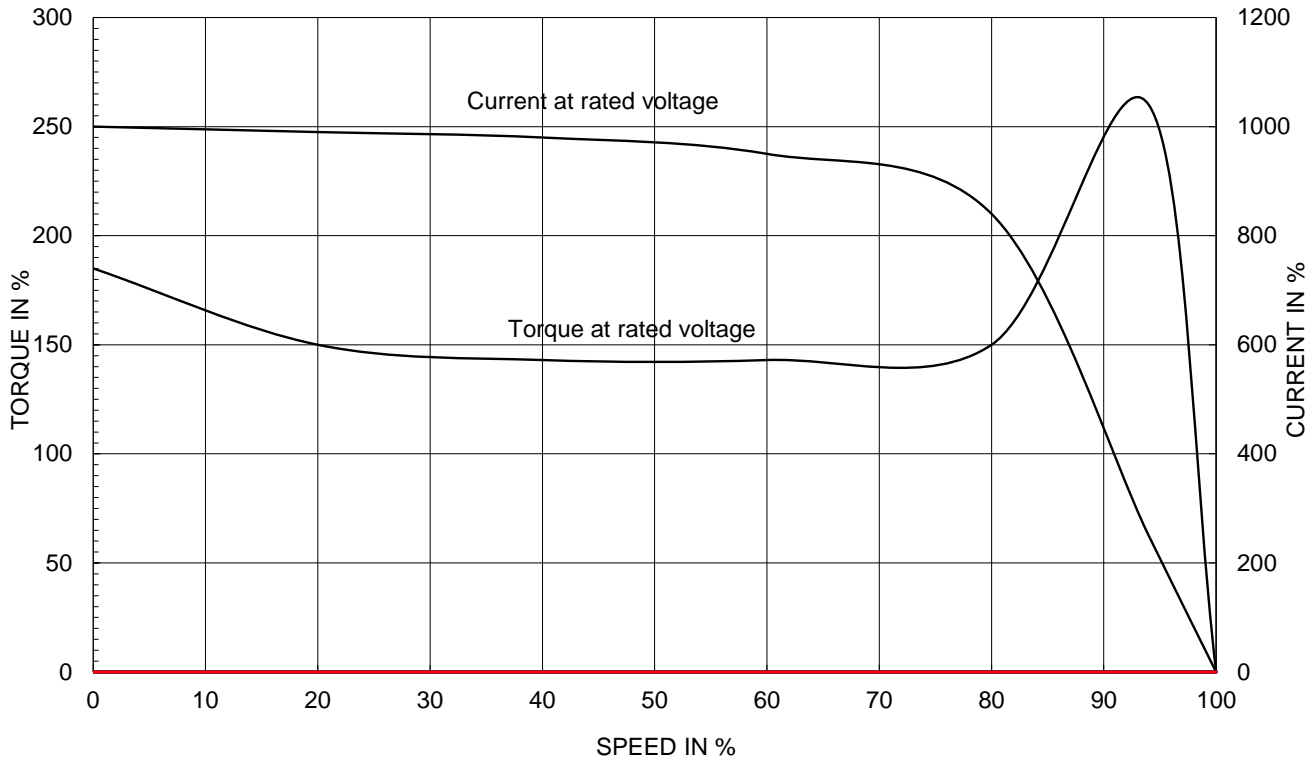

OUTPUT VS EFF., P.F & CURRENT CURVE

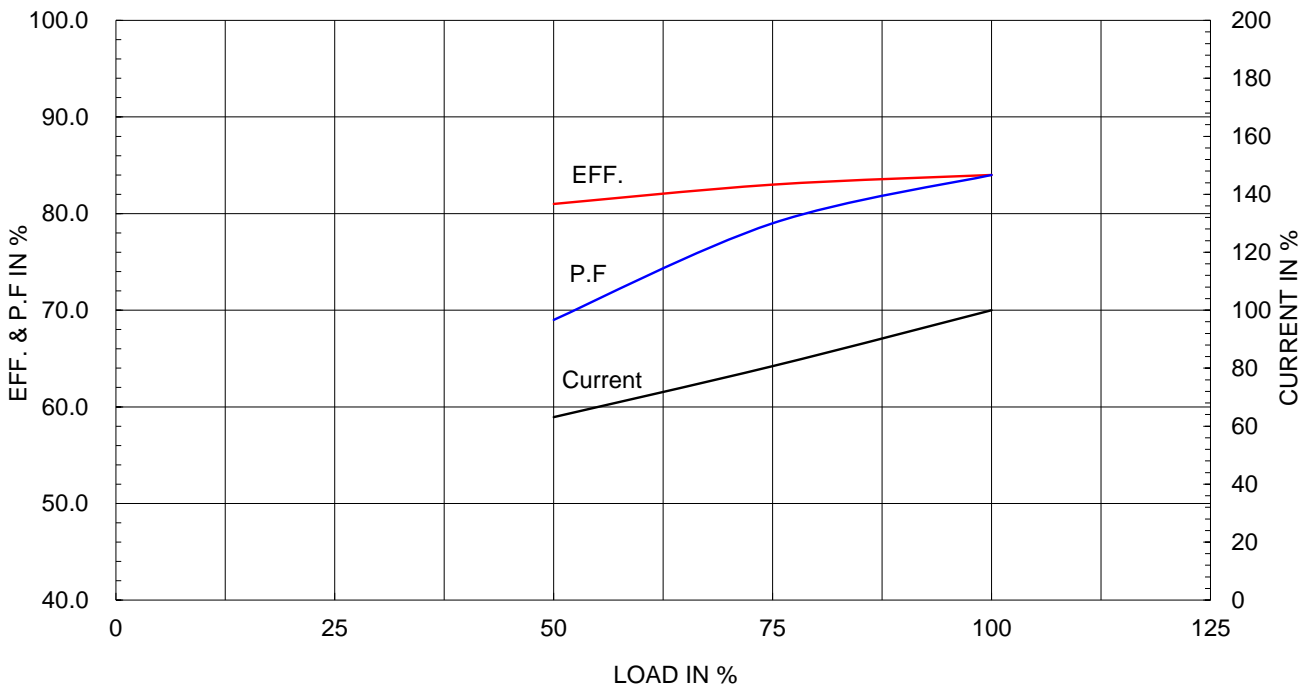

본 도면은 HD현대일렉트릭(주) 재산이며 허가없이 복사할 수 없음 (취급주의)

THIS DRAWING IS PROPRIETARY TO HYUNDAI ELECTRIC. NO PART OF THIS DRAWING MAY BE REPRODUCED WITHOUT THE PERMISSION OF HYUNDAI ELECTRIC.

▽	50S	REV	DATE	CONTENTS	REVD BY	CHKD BY	CHKD BY	APPD BY
▽▽	12.5S							
▽▽▽	3.2S							
▽▽▽▽	0.4S							

IEEE841

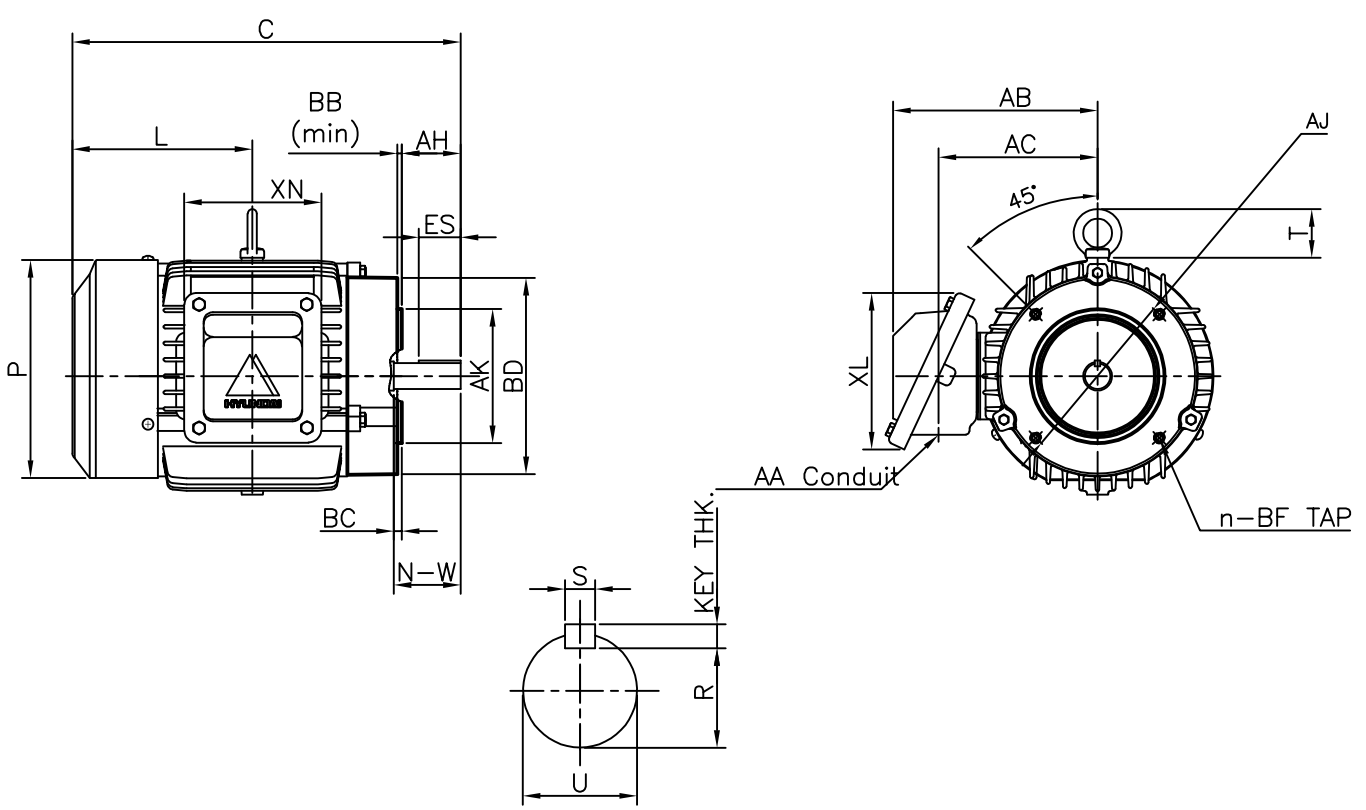

DIMENSIONS

Unit : inch

FLANGE							CONDUIT BOX					APPROX. WGT.(LB)
AJ	AK	BD	BB	BC	BF	n	AA	AB	AC	XL	XN	
5.875	4.50	6.57	0.16	+0.12	3/8-16	4	0.75	7.02	5.34	5.26	4.61	53

OVERALL				SHAFT						KEY THK.	BEARING	
C	L	P	T	U	N-W	A-H	KEYWAY				DRIVE END	OPP. DRIVE END
							R	ES	S			
13.05	6.05	7.33	1.63	0.875	2.25	2.12	0.771	1.41	0.188	0.188	6205Z	6204Z

[NOTE]

- 1.Dimension "D" tolerance : +0.00inch - 0.03inch
- 2.Dimension "U" tolerance : +0.000inch - 0.0005inch
- 3.Dimension "R" tolerance : +0.000inch - 0.015inch

APPD BY	S.Y.KIM	UNIT	INCH	SUBJECT	NEMA 143TCH		DWG SIZE
CHKD BY	R.G.KIM	SCALE	NONE	TITLE	OUTLINE		A4 (1:1)
CHKD BY	Y.H.BAE	PROJEC'N	3각법(3rd Angle)				
DSND BY	H.K.LEE	DATE	2021-04-30				



REF. NO	350A8501AA	Sheet No.	of
DWG NO	LM-I1143C5PL001	Revision No.	0

**Cls. I&II, Div. 2
IEEE 841**

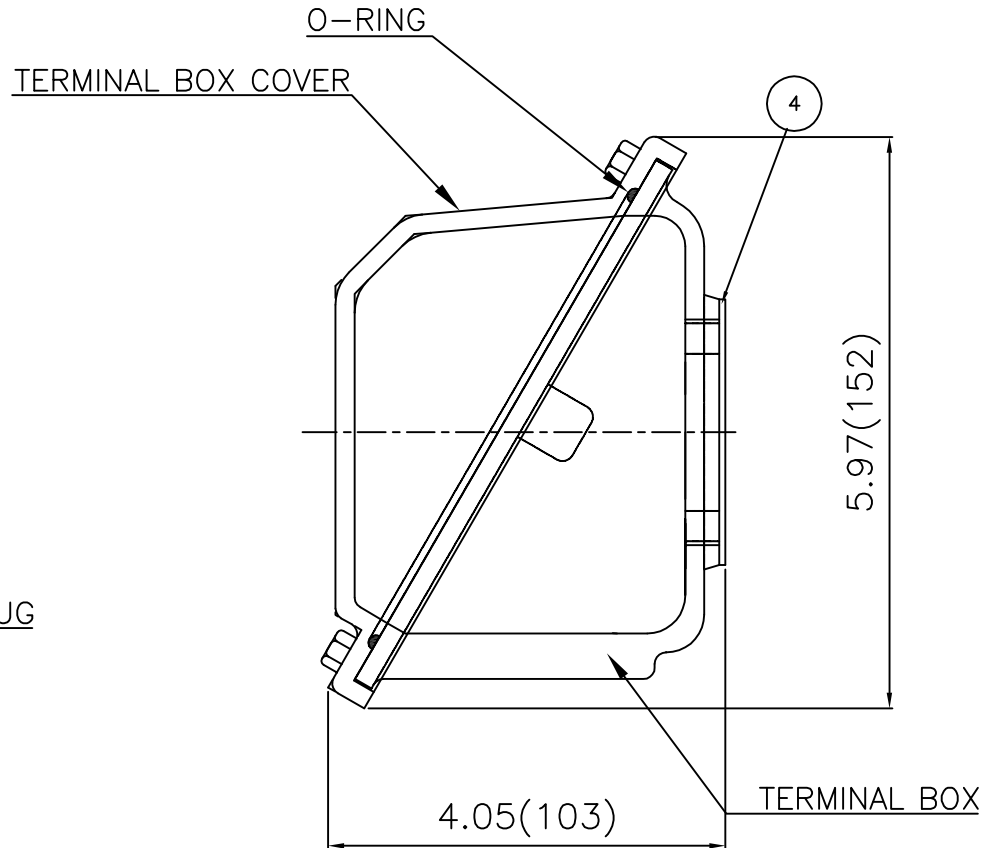
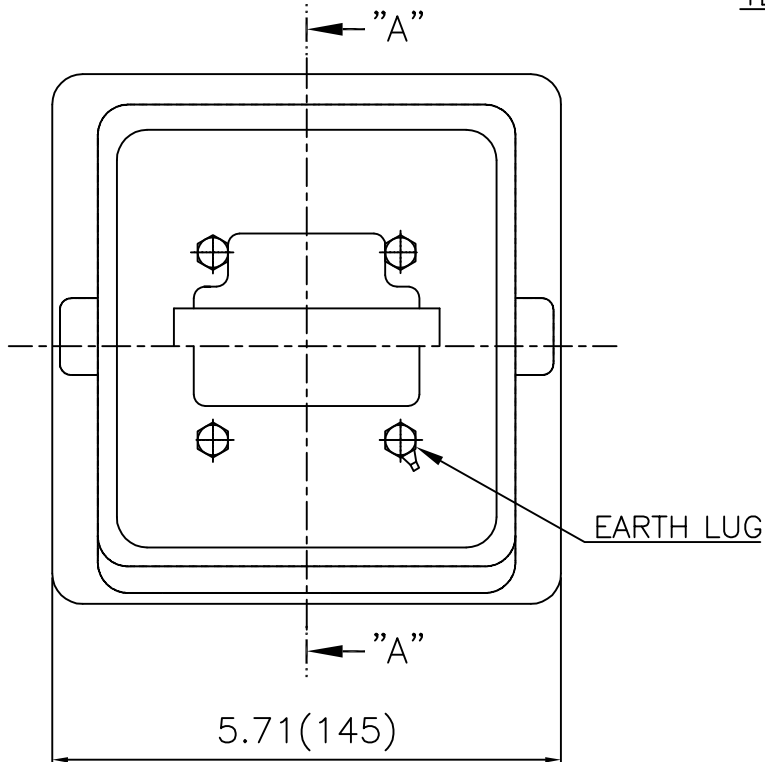

SEC. "A" - "A"

▽	50S
▽▽	12.5S
▽▽▽	3.2S
▽▽▽▽	0.4S

REV	DATE	CONTENTS	REVD BY	CHKD BY	CHKD BY	APPD BY

일반기공차		일반계공차	
1-4	±0.1	6-30	±0.5
4-18	±0.2	30-120	±0.8
18-63	±0.3	120-315	±1.2
63-250	±0.5	315-1000	±2.0
250-	±0.8	1000-	±3.0

Q'TY	DESCRIPTION	MATERIAL	DIMENSION	WEIGHT	PART NO.	REMARK	NO.
APPD BY	S.Y.KIM	UNIT	inch(mm)	SUBJECT	FR. 140 (CAST IRON)	DWG SIZE	A3 (1:1.5)
CHKD BY	I.K.KIM	SCALE	1/2	TITLE			
CHKD BY		PROJEC'N	3rd Angle	TERMINAL BOX ASS'Y			
DSND BY	E.J.KIM	DATE	2024-02-02	REF. NO		Sheet No.	of
		DWG NO	3M-249376	Revision No. 0			