

Customer :
Project Name :
Project No. :
Revision No. :

SPECIFICATION for INDUCTION MOTOR



0		For Bidding			
No.	DATE	DESCRIPTION	PREPARED BY	CHECKED BY	APPROVED BY



AC INDUCTION MOTOR DATA SHEET

Catalog No.	HSDE400-36-L449TS-IBSHSP	Item No.		Rev. No.	[]
Project Name		Project No.		Quantity	sets

GENERAL SPECIFICATION			PERFORMANCE DATA			
Frame Size	L449TS	Rated Output	300 kW 400 HP			
Type	PJP	Number of Poles	2			
Enclosure(Protection)	Totally Enclosed / IP55	Rotor Type	Squirrel Cage			
Method of Cooling	IC411(FC)	Starting Method*	D.O.L			
Rated Frequency	60 Hz	Rated Voltage	575 V	460 V	230 V	
Number of Phases	3	Current	Full Load	349.4 A	436.7 A 873.4 A	
Insulation Class	F		Locked-rotor**	680 %	680 % 680 %	
Temp. Rise at full load (by resistance method)		Efficiency				
at 1.0 S.F	80 deg. C	50% Load		92.8 %		
Motor Location	<input type="checkbox"/> Indoor <input type="checkbox"/> Outdoor	75% Load		94.8 %		
Altitude	Less than 1,000 meter	100% Load		95.8 %		
Relative Humidity	Less than 80 %	Power Factor(p.u)				
Ambient Temp.	40 deg. C (Max.)	50% Load		0.750		
Duty Type	Continuous (S1)	75% Load		0.850		
Service Factor	1.15	100% Load		0.900		
Mounting	B3	Speed at Full Load		3570 r.p.m		
Bearing	Type	Anti-Friction				
	DE/N-DE	6315C3 / 6315C3-INS.				
	Lubricant	Grease(Polyrex-EM)				
External Thrust	Not applicable					
Coupling Method	<input checked="" type="checkbox"/> Direct <input type="checkbox"/> V-belt	Torque				
Shaft Extension	Single	Full Load		592.0 lb.ft		
Terminal Box	Main	Cast Iron				
	Aux.	Yes				
	Location	Refer to Outline Drawing				
Application		Locked-rotor**		145 %		
Area classification	Hazardous	Breakdown**		240 %		
Type of Ex-Protection	Class I&II, Division 2	Moment of Inertia (J)				
Applicable Standard	NEMA MG1, CSA C390	Load(Max.)		315.000 lb.ft2		
		Motor		60.755 lb.ft2		
		Sound Pressure Level (No-load & mean value at 1m from motor)				
		87 dB(A)				
		Vibration				
		3.8 mm/sec (peak)				
		Permissible number of consecutive starts		Cold 2 times		
				Hot 1 time		
		Paint	Munsell No.	4.0PB5.4/5.5(VL-451)		

ACCESSORIES

*. Space Heater : 1EA/Motor

SPARE PARTS

1. Spare Axial Fan (C.W Direction)

SUBMITTAL DRAWING

Outline Dimension Drawing		Motor Weight(Approx.)	
B3	LM-T044XB3CE001	3820 lb.	

REMARK

1. Premium efficiency according to NEMA MG1
2. Inverter Duty @ 1.0 Service Factor & F Temperature rise
 - . 10:1 VT (20:1 VT at 50% load)
 - . 10:1 CT
 - . CHp up to 1.5 times base speed, NEMA MG1 Part31
3. NDE side : Insulated bearing
4. CSA Certification
 - . Class I, Division 2, Group A, B, C & D; Temp code : T3
 - . Class II, Division 2 Group F & G; Temp code : T3
5. Uni-directional CCW viewed from drive end.

Date	DSND	CHKD	CHKD	APPD
2024-07-13	S.H. Lee	I.K. Kim	R.G. Kim	S.W. Kim

[Note] Others not mentioned in this data sheet shall be in accordance with maker standard.
 Above technical data are only design values and shall be guaranteed with tolerance of applicable standard.
 Inspection and performance test shall be done according to maker standard, if not mentioned.
 * In case of Inverter-Fed Motor, performance data is based on sine wave tests. It may be different from test data of Inverter combined motor.
 ** Data is based on rated voltage & frequency and is expressed as a percentage of full-load value.

본 도면은 HD현대일렉트릭(주) 재산이며 허가없이 복사할 수 없음 (취급유의)



THIS DRAWING IS PROPRIETARY TO HYUNDAI ELECTRIC. NO PART OF THIS DRAWING MAYBE REPRODUCED WITHOUT THE PERMISSION OF HYUNDAI ELECTRIC.

1	2	3	4
REV	DATE	CONTENTS	REVD BY

4.72

CROWN TRITON

Premium Efficiency AC 3 Phase Motor







400HP	2P	460V	Cat. No.	HSDE400-36-L449TS-IBSHSP			
Model	LATER		INS. Class	F	Amps	436.7	
Type	PJP	Duty	CONT	Code	G	Amb. 40°C	
Hertz	60Hz						
Frame	L449TS	Encl.	TEFC	S.F.	1.15	RPM	3570
NEMA Nom. Eff.	95.8%						
Bearing	Drive	6315C3		S.F.1.00 (10:1 C.T., 20:1 V.T., NEMA-MG1 Part31)		3/4 Eff.	94.8%
	Opp.	6315C3-INS.				NEMA Design	B
Usable at							
CSA Certified for	CLASS I, Div. 2, Gr. A, B, C & D		CLASS II, Div. 2, Gr. F & G		Temp. Code (sine wave)	Frame	L440FR - 500FR
	CLASS I, Zone 2, Gr. IIA, IIB, & IIC					Amb. 40°C	T3 (200°C)
						Amb. 55°C	T3 (200°C)
No.	-	Date	-	Weight	3820 lb		
4M-136053		Made in Korea H1					

2.36

MARINE DUTY IEEE45

APPD BY	S.Y.KIM	UNIT	INCH	SUBJECT	CSA Class I, Division2 Severe Duty (HSDE ,L449-500)	DWG SIZE
CHKD BY	I.K.KIM	SCALE	NONE			A4 (1:1)
CHKD BY	R.G.KIM	PROJEC'N	3rd Angle	TITLE NAMEPLATE DRAWING		
DSND BY	S.H.LEE	DATE	2024.06.07			
				REF. NO	4M-136053	Sheet No. of
				DWG NO	NP-HSDE400-36-L449TS-IBSHSP	Revision No. 0

Type :	PJP
Full Load Torque :	592.0 lb.ft
Load moment of Inertia (J) :	315.000 lb.ft2
Motor moment of Inertia (J) :	60.755 lb.ft2

300kW	400HP	2 P	60 Hz
Speed at Full Load :			3570 RPM
Rated Voltage	575V	460V	230V
Full Load Current	349.4A	436.7A	873.4A

SPEED VS TORQUE & CURRENT CURVE

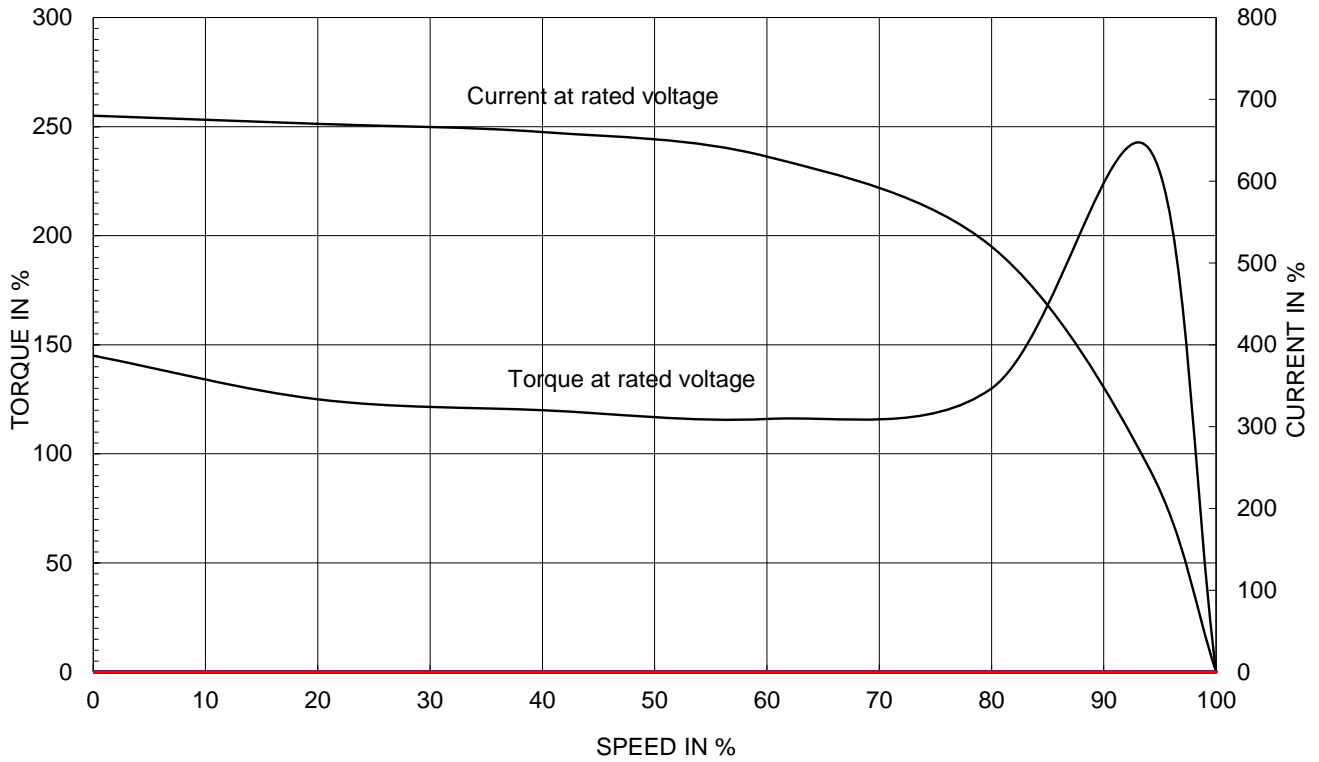

OUTPUT VS EFF., P.F & CURRENT CURVE

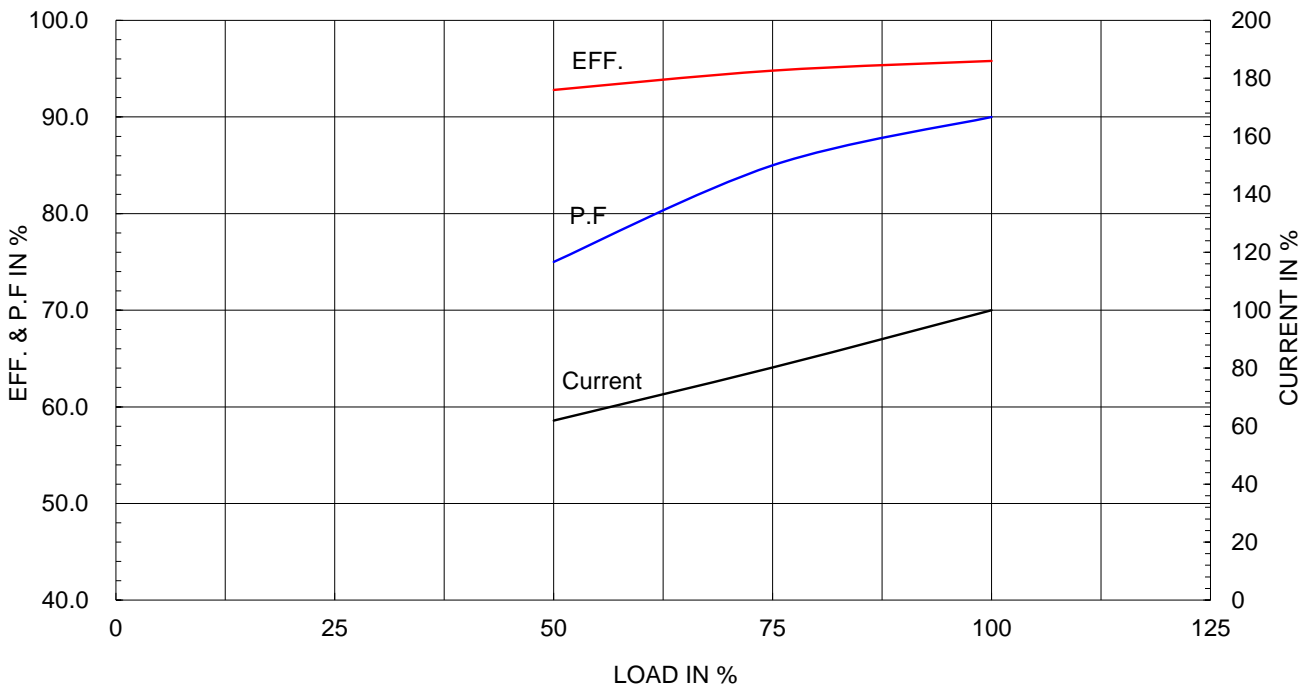

본 도면은 HD현대일렉트릭(주) 재산이며 허가없이 복사할 수 없음 (취급유의)

THIS DRAWING IS PROPRIETARY TO HYUNDAI ELECTRIC. NO PART OF THIS DRAWING MAYBE REPRODUCED WITHOUT THE PERMISSION OF HYUNDAI ELECTRIC.

1	2	3	4
▽	50S	REV	DATE
▽▽	12.5S		
▽▽▽	3.2S		
▽▽▽▽	0.4S		
REVD BY	CHKD BY	CHKD BY	APPD BY

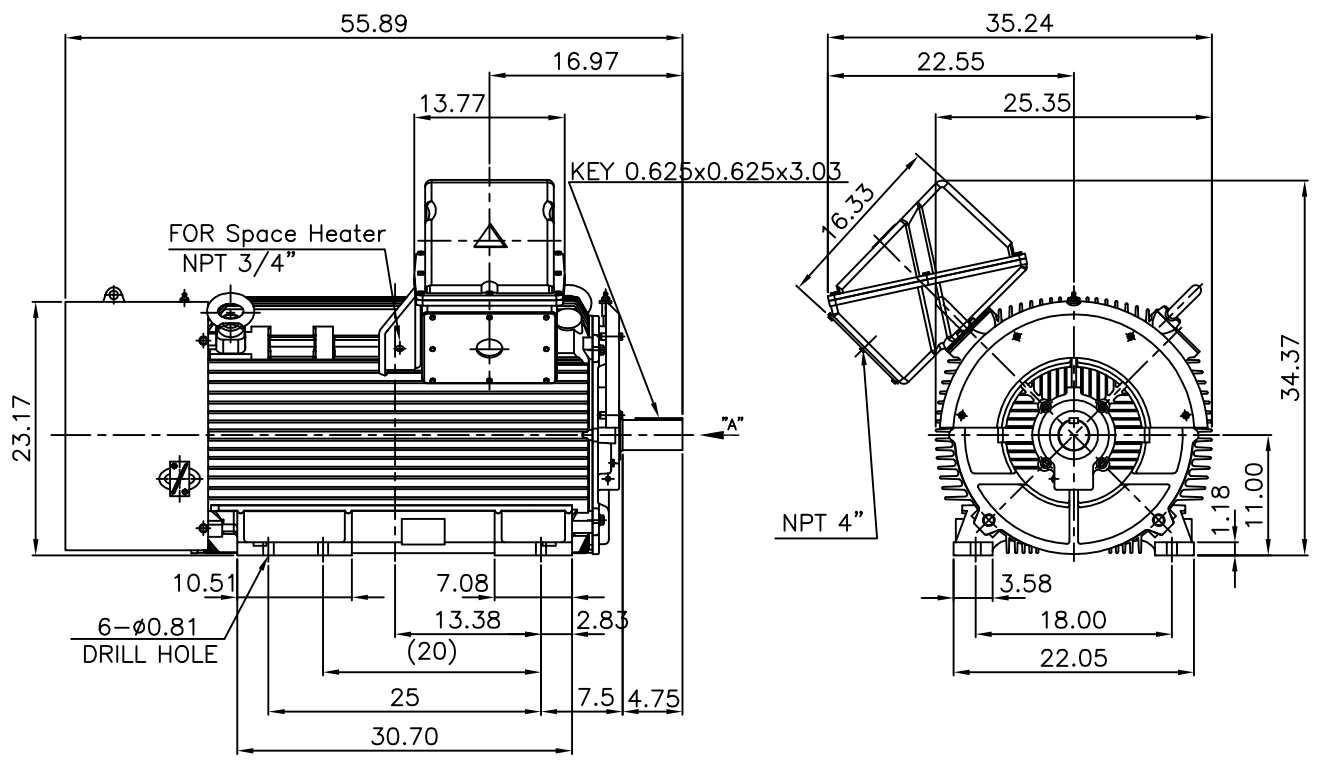

NOTE

1.TOLERANCE :

CENTER HEIGHT	11	+0.000	-0.060
SHAFT DIAMETER	ø2.375	+0.000	-0.001
KEYWAY WIDTH	0.625	+0.002	-0.000

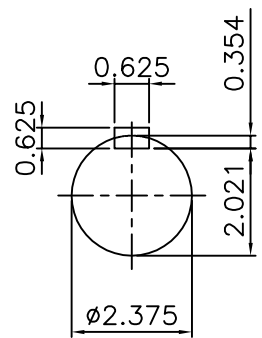

VIEW "A"

APPD BY	S.Y.KIM	UNIT	INCH	SUBJECT	Fr.L449TS	DWG SIZE	A4 (1:18)
CHKD BY	O.J.KIM	SCALE	1/18	TITLE	NEMA STD SHAFT(AISI 1045 SHAFT)		
CHKD BY	R.G.KIM	PROJEC'N	3각법 (3rd Angle)	OUTLINE			
DSND BY	H.K.LEE	DATE	2021-04-27				
				REF. NO		Sheet No.	of
				DWG NO	LM-T044XB3CE001	Revision No.	0

**Cls. I&II, Div. 2
IEEE 841**



SEC. "A" - "A"

REV	DATE	CONTENTS	REVD BY	CHKD BY	CHKD BY	APPD BY

APPD BY	S.Y.KIM	UNIT	inch(mm)	SUBJECT	FR. L440 (CAST IRON)	DWG SIZE
CHKD BY		SCALE	1/3.5	TITLE	MAIN TERMINAL BOX ASS'Y	A3 (1:3.5)
CHKD BY	R.G.KIM	PROJEC'N	3rd Angle			
DSND BY	최승희	DATE	2023-10-19			
				REF. NO		Sheet No. of
				DWG NO	3M-248452	Revision No. 0

**Cls. I&II, Div. 2
IEEE 841**

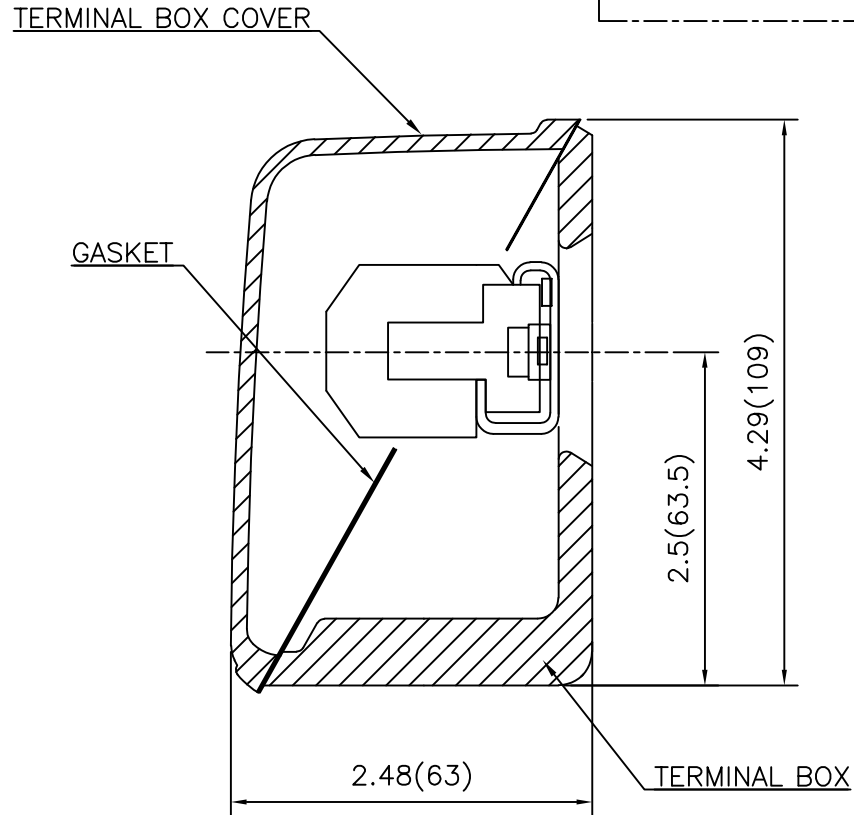
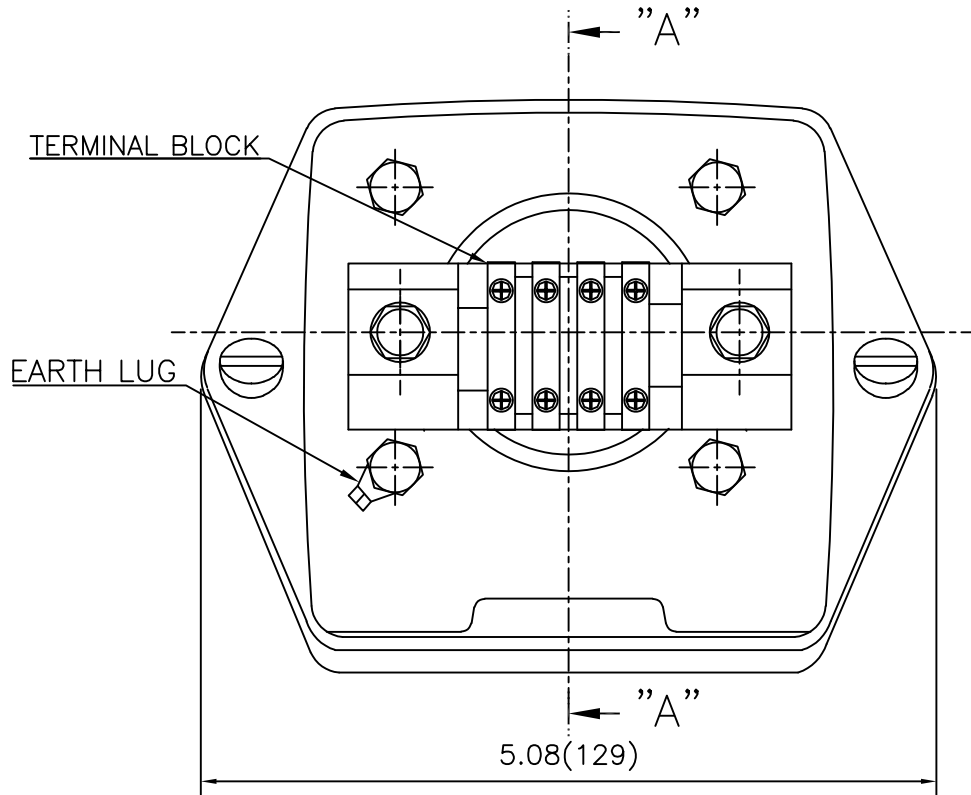

SEC. "A" - "A"

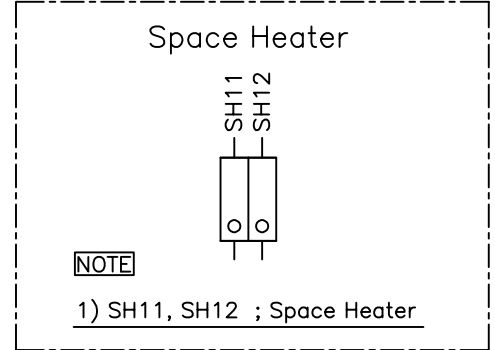

REV	DATE	CONTENTS	REVD BY	CHKD BY	CHKD BY	APPD BY

APPD BY	S.Y.KIM	UNIT	inch(mm)	SUBJECT	FR.180 (CAST IRON)	DWG SIZE
CHKD BY		SCALE	1/1	TITLE	SUB. TERMINAL BOX ASS'Y	A3 (1:1.1)
CHKD BY	R.G.KIM	PROJEC'N	3rd Angle			
DSND BY	배승희	DATE	2024-01-18			
				REF. NO		Sheet No. of
				DWG NO	3M-165277	Revision No. 0