

Customer :  
Project Name :  
Project No. :  
Revision No. :

# SPECIFICATION for INDUCTION MOTOR



0		For Bidding			
No.	DATE	DESCRIPTION	PREPARED BY	CHECKED BY	APPROVED BY



# AC INDUCTION MOTOR DATA SHEET

Catalog No.	HSDE350-12-L449TC-IBSH	Item No.	Rev. No. [     ]
Project Name		Project No.	Quantity                      sets

GENERAL SPECIFICATION		PERFORMANCE DATA				
Frame Size	L449TC	Rated Output	261 kW                      350 HP			
Type	PJP	Number of Poles	6			
Enclosure(Protection)	Totally Enclosed / IP55	Rotor Type	Squirrel Cage			
Method of Cooling	IC411(FC)	Starting Method*	D.O.L			
Rated Frequency	60 Hz	Rated Voltage	575 V	460 V	230 V	
Number of Phases	3	Current	Full Load	325.7 A	407.1 A	814.2 A
Insulation Class	F		Locked-rotor**	650 %	650 %	650 %
Temp. Rise at full load (by resistance method)		Efficiency				
at 1.0 S.F	80 deg. C	50% Load		92.8 %		
Motor Location	<input type="checkbox"/> Indoor <input type="checkbox"/> Outdoor	75% Load		94.8 %		
Altitude	Less than 1,000 meter	100% Load		95.8 %		
Relative Humidity	Less than 80 %	Power Factor(p.u)				
Ambient Temp.	40 deg. C (Max.)	50% Load		0.690		
Duty Type	Continuous ( S1 )	75% Load		0.790		
Service Factor	1.15	100% Load		0.840		
Mounting	B35	Speed at Full Load		1185 r.p.m		
Bearing	Type	Anti-Friction				
	DE/N-DE	6322C3 / 6318C3-INS.				
	Lubricant	Grease(Polyrex-EM)				
External Thrust	Not applicable					
Coupling Method	<input checked="" type="checkbox"/> Direct <input type="checkbox"/> V-belt	Torque				
Shaft Extension	Single	Full Load		1,551.7 lb.ft		
Terminal Box	Main	Cast Iron				
	Aux.	Yes				
	Location	Refer to Outline Drawing				
Application		Moment of Inertia (J)				
Area classification	Hazardous	Load(Max.)		3,240.000 lb.ft2		
Type of Ex-Protection	Class I&II, Division 2	Motor		172.297 lb.ft2		
Applicable Standard	NEMA MG1, CSA C390	Sound Pressure Level (No-load & mean value at 1m from motor)				
<b>ACCESSORIES</b> *. Space Heater : 1EA/Motor		Vibration				3.8 mm/sec (peak)
		Permissible number of consecutive starts		Cold	2 times	
				Hot	1 time	
		Paint	Munsell No.	4.0PB5.4/5.5(VL-451)		
		<b>SUBMITTAL DRAWING</b>				
		Outline Dimension Drawing		Motor Weight(Approx.)		
		B35	LM-T044XC4UE001	3490 lb.		
		<b>REMARK</b>				
		1. Premium efficiency according to NEMA MG1 2. Inverter Duty @ 1.0 Service Factor & F Temperature rise -. 10:1 VT (20:1 VT at 50% load) -. 10:1 CT -. CHp up to 1.5 times base speed, NEMA MG1 Part31 3. NDE side : Insulated bearing 4. CSA Certification -. Class I, Division 2, Group A, B, C & D; Temp code : T3 -. Class II, Division 2 Group F & G; Temp code : T3 5. Shaft material : AISI4140				
		Date	DSND	CHKD	CHKD	APPD
		2024-07-13	S.H. Lee	I.K. Kim	R.G. Kim	S.W. Kim

<b>SPARE PARTS</b>  	
----------------------------	--



[Note] Others not mentioned in this data sheet shall be in accordance with maker standard.  
 Above technical data are only design values and shall be guaranteed with tolerance of applicable standard.  
 Inspection and performance test shall be done according to maker standard, if not mentioned.  
 \* In case of Inverter-Fed Motor, performance data is based on sine wave tests. It may be different from test data of Inverter combined motor.  
 \*\* Data is based on rated voltage & frequency and is expressed as a percentage of full-load value.

1	2	3	4
REV	DATE	CONTENTS	REVD BY   CHKD BY   CHKD BY   APPD BY

4.72

## CROWN TRITON

Premium Efficiency AC 3 Phase Motor



350HP 6P 460V		Cat. No. HSDE350-12-L449TC-IBSH	
Model	LATER	INS. Class	F
Type	PJP	Duty	CONT
Frame	L449TC	Encl.	TEFC
Bearing	Drive	6322C3	S.F. 1.15 RPM 1185
	Opp.	6318C3-INS.	
Usable at		NEMA Nom. Eff. 95.8%	
CSA Certified for	CLASS I, Div. 2, Gr. A, B, C & D	CLASS II, Div. 2, Gr. F & G	Temp. Code (sine wave)
	CLASS I, Zone 2, Gr. IIA, IIB, & IIC		
No.	-	Date	-
4M-136053		Weight 3490 lb	

**MARINE DUTY IEEE45**      Made in Korea H1      **HD HYUNDAI ELECTRIC**

2.36

APPD BY	S.Y.KIM	UNIT	INCH	SUBJECT	CSA Class I, Division2 Severe Duty (HSDE ,L449-500)	DWG SIZE
CHKD BY	I.K.KIM	SCALE	NONE			
CHKD BY	R.G.KIM	PROJEC'N	3rd Angle			
DSND BY	S.H.LEE	DATE	2024.06.07			



REF. NO	<b>4M-136053</b>	Sheet No. of
DWG NO	NP-HSDE350-12-L449TC-IBSH	Revision No. <b>0</b>

Type :	PJP
Full Load Torque :	1551.7 lb.ft
Load moment of Inertia (J) :	3240.000 lb.ft <sup>2</sup>
Motor moment of Inertia (J) :	172.297 lb.ft <sup>2</sup>

261kW 350HP	6 P	60 Hz
Speed at Full Load :		1185 RPM
Rated Voltage	575V	460V 230V
Full Load Current	325.7A	407.1A 814.2A

SPEED VS TORQUE & CURRENT CURVE

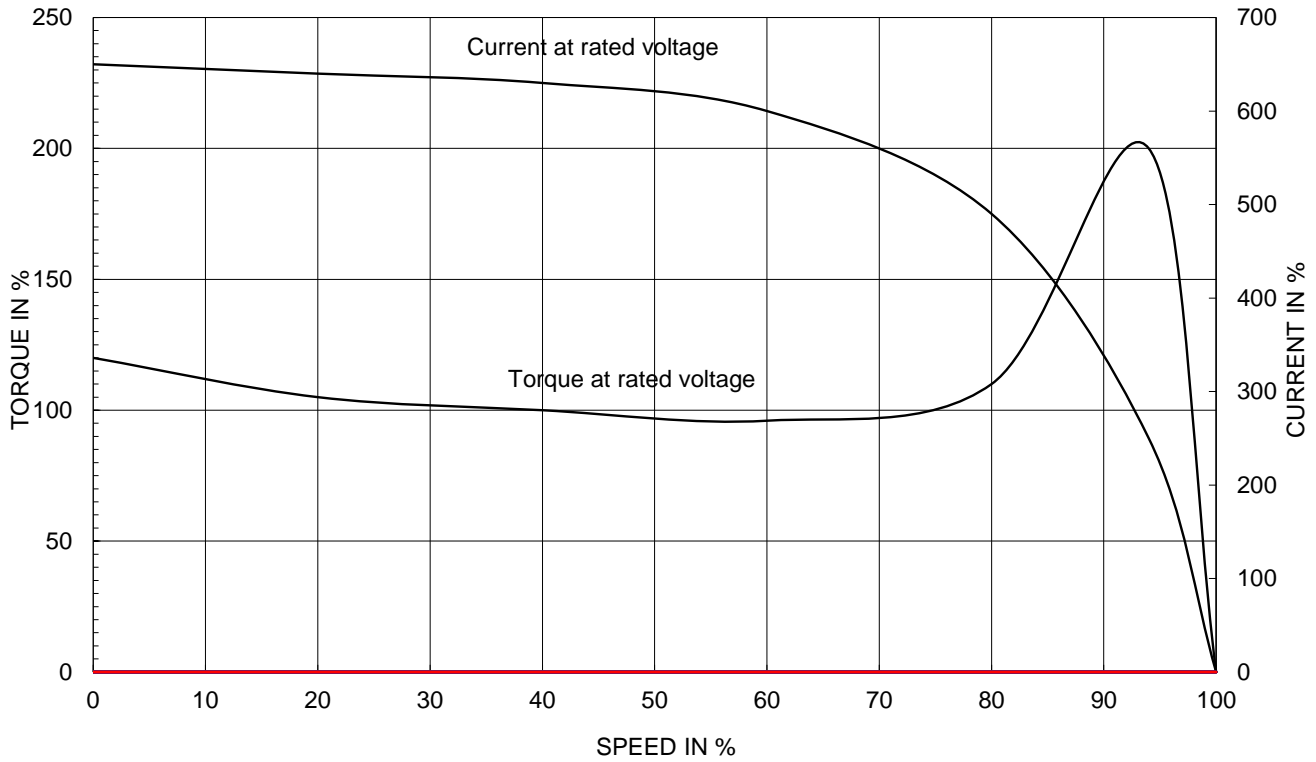

OUTPUT VS EFF., P.F & CURRENT CURVE

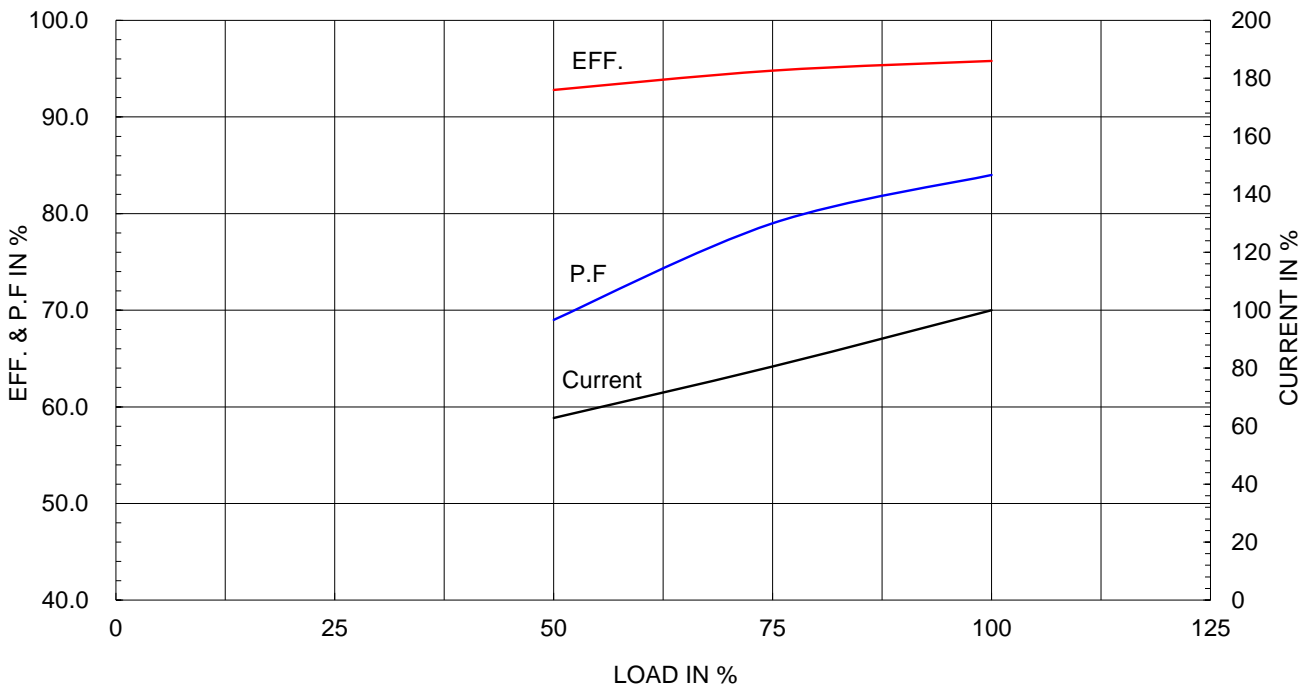

본 도면은 HD현대일렉트릭(주) 재산이며 허가없이 복사할 수 없음 (취급유의)

THIS DRAWING IS PROPRIETARY TO HYUNDAI ELECTRIC. NO PART OF THIS DRAWING MAYBE REPRODUCED WITHOUT THE PERMISSION OF HYUNDAI ELECTRIC.

1	2	3	4
▽	50S	REV	DATE
▽▽	12.5S		
▽▽▽	3.2S		
▽▽▽▽	0.4S		
CONTENTS	REVD BY	CHKD BY	CHKD BY
			APPD BY

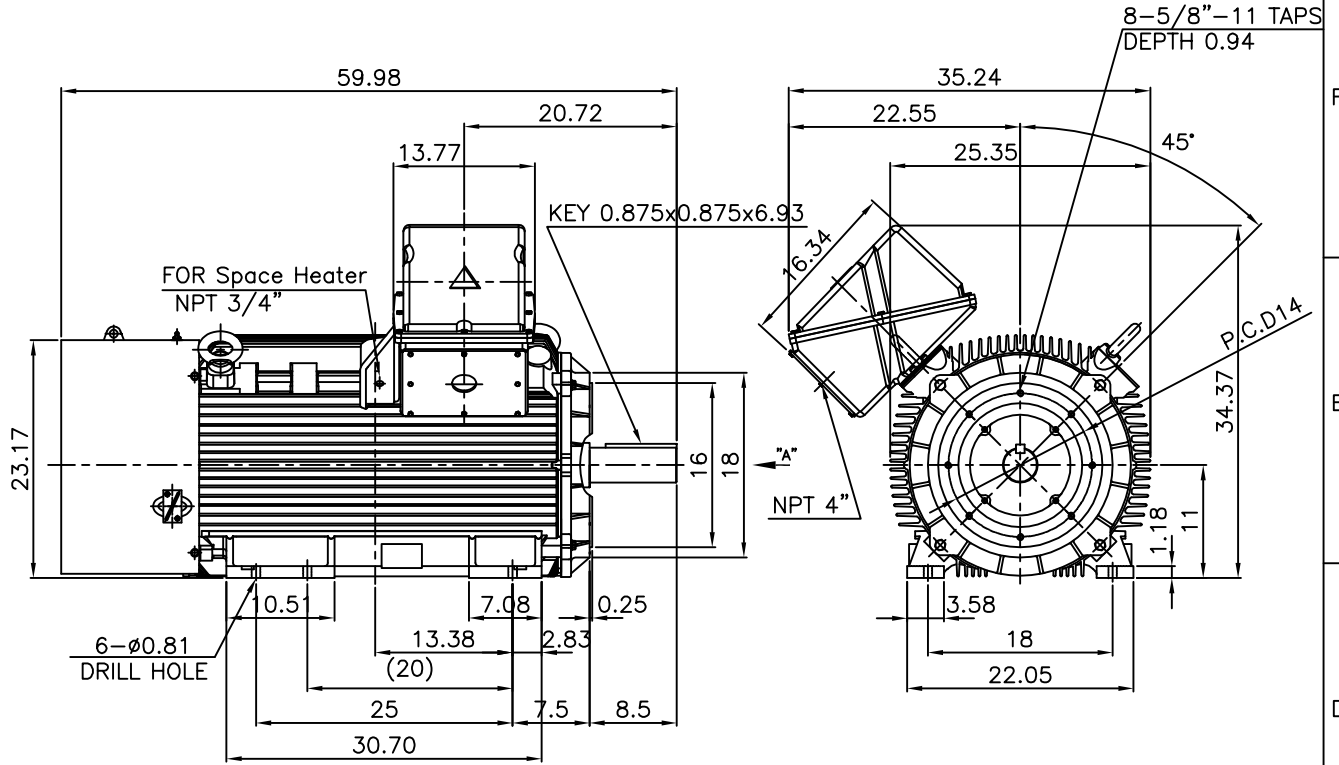

**NOTE**

1.TOLERANCE :

CENTER HEIGHT	11	+0.000	-0.060
RABBET DIAMETER	ø16	0	-0.005
SHAFT DIAMETER	ø3.375	+0.000	-0.001
KEYWAY WIDTH	0.875	+0.003	-0.000

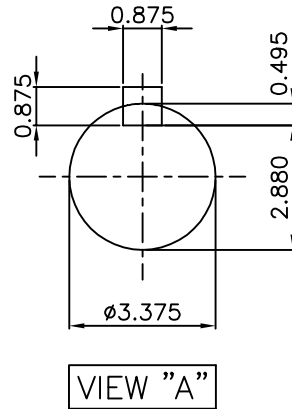

APPD BY	S.Y.KIM	UNIT	INCH	SUBJECT	Fr.L449TC	DWG SIZE	A4 (1:18)
CHKD BY	O.J.KIM	SCALE	1/18	TITLE	NEMA STD SHAFT(4140 SHAFT)		
CHKD BY	R.G.KIM	PROJEC'N	3각법(3rd Angle)	<b>OUTLINE</b>			
DSND BY	H.K.LEE	DATE	2021-04-27				
				REF. NO		Sheet No.	of
				DWG NO	LM-T044XC4UE001	Revision No.	0

**Cls. I&II, Div. 2  
IEEE 841**



SEC. "A" - "A"

REV	DATE	CONTENTS	REVD BY	CHKD BY	CHKD BY	APPD BY

APPD BY	S.Y.KIM	UNIT	inch(mm)	SUBJECT	FR. L440 (CAST IRON)	DWG SIZE
CHKD BY		SCALE	1/3.5	TITLE	MAIN TERMINAL BOX ASS'Y	A3 (1:3.5)
CHKD BY	R.G.KIM	PROJEC'N	3rd Angle			
DSND BY	최승희	DATE	2023-10-19			
				REF. NO		Sheet No. of
				DWG NO	3M-248452	Revision No. 0

**Cls. I&II, Div. 2  
IEEE 841**

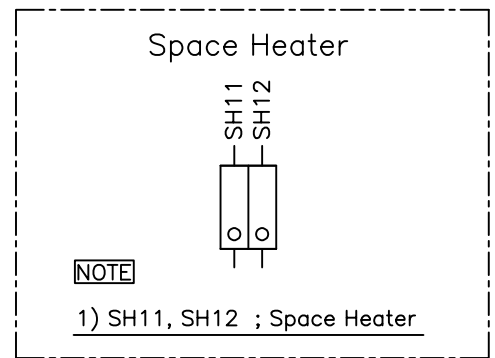
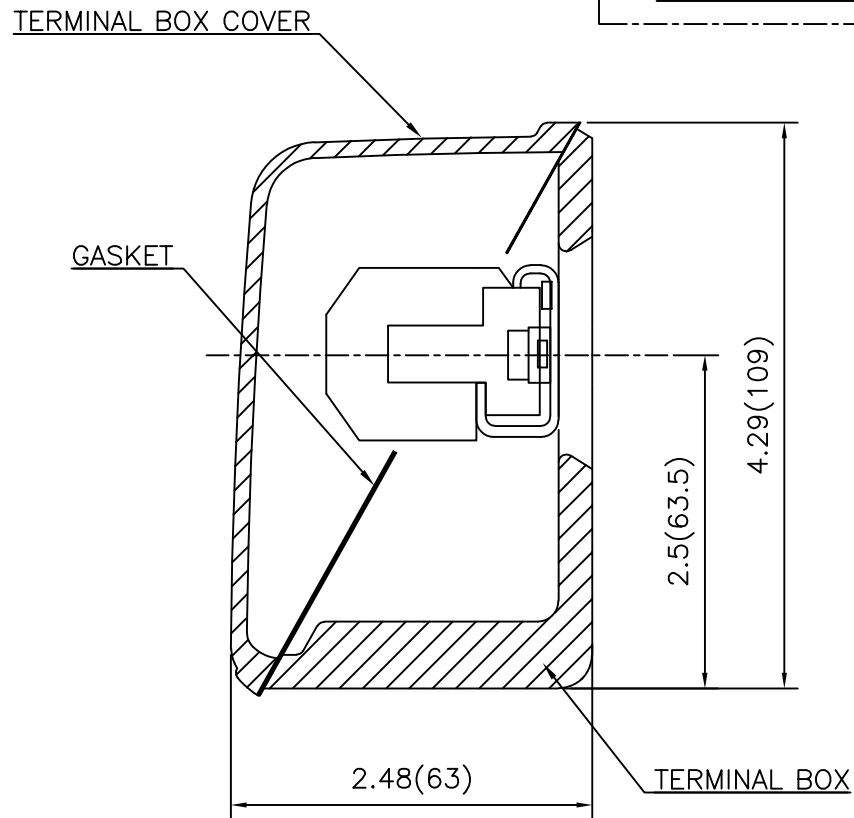
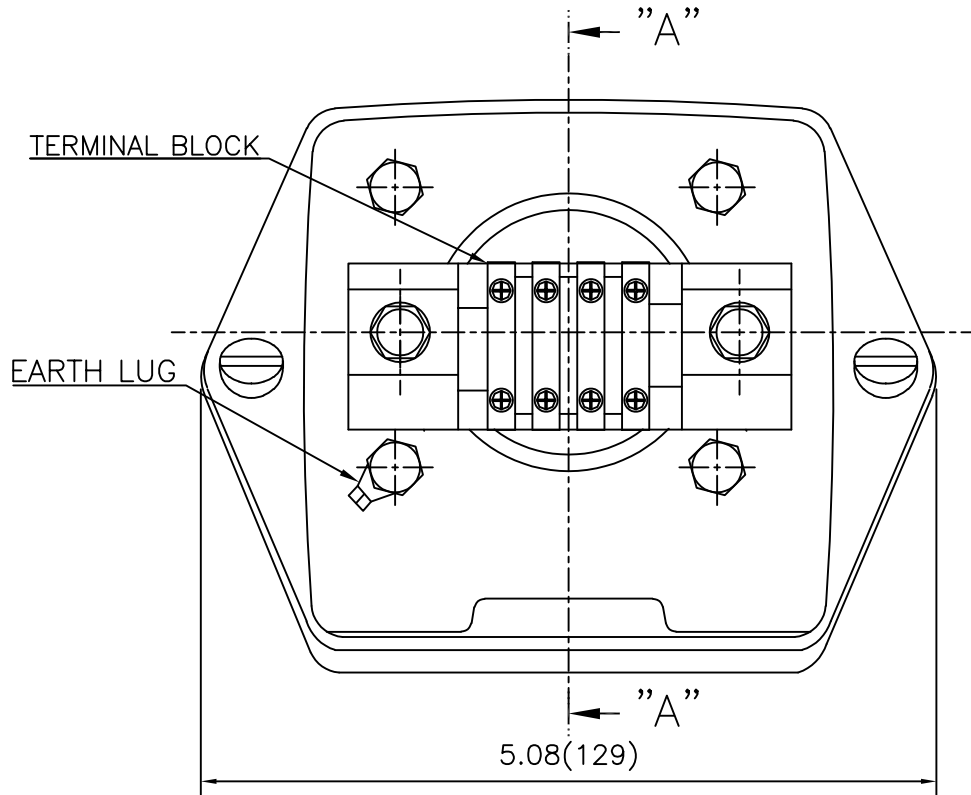

REV	DATE	CONTENTS	REVD BY	CHKD BY	CHKD BY	APPD BY

APPD BY	S.Y.KIM	UNIT	inch(mm)	SUBJECT	FR.180 (CAST IRON)	DWG SIZE
CHKD BY		SCALE	1/1	TITLE	SUB. TERMINAL BOX ASS'Y	
CHKD BY	R.G.KIM	PROJEC'N	3rd Angle	REF. NO		Sheet No. of
DSND BY	배승희	DATE	2024-01-18	DWG NO	3M-165277	Revision No. 0

