

Customer :  
Project Name :  
Project No. :  
Revision No. :

# SPECIFICATION for INDUCTION MOTOR



0		For Bidding			
No.	DATE	DESCRIPTION	PREPARED BY	CHECKED BY	APPROVED BY



# AC INDUCTION MOTOR DATA SHEET

Catalog No.	HHI75-18-365TCRD	Item No.	Rev. No.	[      ]
Project Name		Project No.	Quantity	sets

GENERAL SPECIFICATION			PERFORMANCE DATA			
Frame Size	365TC		Rated Output	55 kW      75 HP		
Type	PJP		Number of Poles	4		
Enclosure(Protection)	Totally Enclosed	/ IP55	Rotor Type	Squirrel Cage		
Method of Cooling	IC411(FC)		Starting Method*	D.O.L		
Rated Frequency	60 Hz		Rated Voltage	575 V	460 V	230 V
Number of Phases	3		Current	Full Load	68.1 A	85.1 A      170.3 A
Insulation Class	F			Locked-rotor**	690 %	690 %      690 %
Temp. Rise at full load (by resistance method)			Efficiency			
at 1.0 S.F	80 deg. C		50% Load		92.4 %	
Motor Location	<input type="checkbox"/> Indoor <input type="checkbox"/> Outdoor		75% Load		94.4 %	
Altitude	Less than 1,000 meter		100% Load		95.4 %	
Relative Humidity	Less than 80 %		Power Factor(p.u)			
Ambient Temp.	40 deg. C (Max.)		50% Load		0.700	
Duty Type	Continuous ( S1 )		75% Load		0.800	
Service Factor	1.15		100% Load		0.850	
Mounting	B5		Speed at Full Load	1780 r.p.m		
Bearing	Type	Anti-Friction	Torque			
	DE/N-DE	6314C3 / 6213C3	Full Load		217.7 lb.ft	
	Lubricant	Grease(Polyrex-EM)	Locked-rotor**		150 %	
External Thrust	Not applicable		Breakdown**		220 %	
Coupling Method	<input checked="" type="checkbox"/> Direct <input type="checkbox"/> V-belt		Moment of Inertia (J)			
Shaft Extension	Single		Load(Max.)		654.961 lb.ft2	
Terminal Box	Main	Cast Iron	Motor		20.900 lb.ft2	
	Aux.	No	Sound Pressure Level (No-load & mean value at 1m from motor)			
Location	Refer to Outline Drawing				82 dB(A)	
Application			Vibration		3.8 mm/sec (peak)	
Area classification	Hazardous		Permissible number of consecutive starts		Cold 3 times Hot 2 times	
Type of Ex-Protection	Class I&II, Division 2		Paint		Munsell No. 4.0PB5.4/5.5(VL-451)	
Applicable Standard	NEMA MG1, CSA C390					

ACCESSORIES

SUBMITTAL DRAWING		
Outline Dimension Drawing	Motor Weight(Approx.)	
B5	LM-T1365C5PL001	910 lb.

**REMARK**

1. Premium efficiency according to NEMA MG1
2. Inverter Duty @ 1.0 Service Factor & F Temperature rise
  - 10:1 VT (20:1 VT at 50% load)
  - 10:1 CT
  - CHP up to 1.5 times base speed, NEMA MG1 Part31
3. CSA Certification
  - Class I, Division 2, Group A, B, C & D
  - Class II, Division 2 Group E, F & G (Group E : up to 320Fr.)
4. Service Factor 1.15 and Temperature rise B are applicable under the condition of sine wave power.
5. Service Factor 1.25 is applicable to motors of 100HP or less with temperature rise F & Non-Hazardous.

Date	DSND	CHKD	CHKD	APPD
2024-07-13	S.H. Lee	I.K. Kim	R.G. Kim	S.W. Kim

[Note] Others not mentioned in this data sheet shall be in accordance with maker standard.  
 Above technical data are only design values and shall be guaranteed with tolerance of applicable standard.  
 Inspection and performance test shall be done according to maker standard, if not mentioned.  
 \* In case of Inverter-Fed Motor, performance data is based on sine wave tests. It may be different from test data of Inverter combined motor.  
 \*\* Data is based on rated voltage & frequency and is expressed as a percentage of full-load value.

1	2	3	4
REV	DATE	CONTENTS	REVD BY   CHKD BY   CHKD BY   APPD BY

4.72

**CROWN TRITON**  
Premium Efficiency AC 3 Phase Motor

75HP	4P	230/460V	Cat. No.	HHI75-18-365TCRD				
Model	HLS365PR04		INS. Class	F	HD-F1	Amps	170.3/85.	
Type	HLS	Duty	CONT	Code	G	Amb.	40°C	
Hertz	60Hz							
Frame	365TC	Encl.	TEFC	S.F.	1.15	RPM	1780	
NEMA Nom. Eff.	95.4%							
Bearing	Drive	6314C3		S.F.1.00 (10:1 C.T., 20:1 V.T., NEMA-MG1 Part31)			3/4 Eff.	94.4%
	Opp.	6213C3					NEMA Design	B
Usable at	50Hz 75HP 380V 102.3A 1475rpm S.F.: 1.0 Eff.: 94.5% Code: E							
	50Hz 75HP 400/415V 98.3/96A 1478/1479rpm S.F.: 1.0 Eff.: 94.8/94.9% Code: F/G							
CSA Certified for	Model	LATER		Type	PJP			
	CLASS I, Div. 2, Gr. A, B, C & D CLASS I, Zone 2, Gr. IIA, IIB, & IIC	CLASS II, Div. 2 Gr. E, F & G (Gr. E : Up to 320FR)		Temp. Code (sine wave)	Frame	140~320FR	360~400FR	440FR
		Amb. 40°C	T3C (160°C)		T3B (165°C)	T3A (180°C)		
Amb. 55°C	T3A (180°C)	T3A (180°C)	T3 (200°C)					
No.	-		Date	-		Weight	910 lb	

4M-135702
Made in Korea H1

2.36

APPD BY	S.Y.KIM	UNIT	INCH	SUBJECT	CSA Class I, Division2 Severe Duty (HHI, 364-449)	DWG SIZE
CHKD BY	I.K.KIM	SCALE	NONE			A4 ( 1:1 )
CHKD BY	R.G.KIM	PROJEC'N	3rd Angle	TITLE <b>NAMEPLATE DRAWING</b>		
DSND BY	S.H.LEE	DATE	2024.06.07			
				REF. NO	<b>4M-135702</b>	Sheet No. of
				DWG NO	<b>NP-HHI75-18-365TCRD</b>	Revision No. <b>0</b>

Type :	PJP	
Full Load Torque :	217.7	lb.ft
Load moment of Inertia (J) :	654.961	lb.ft2
Motor moment of Inertia (J) :	20.900	lb.ft2

55kW	75HP	4 P	60 Hz
Speed at Full Load :			1780 RPM
Rated Voltage	575V	460V	230V
Full Load Current	68.1A	85.1A	170.3A

SPEED VS TORQUE & CURRENT CURVE

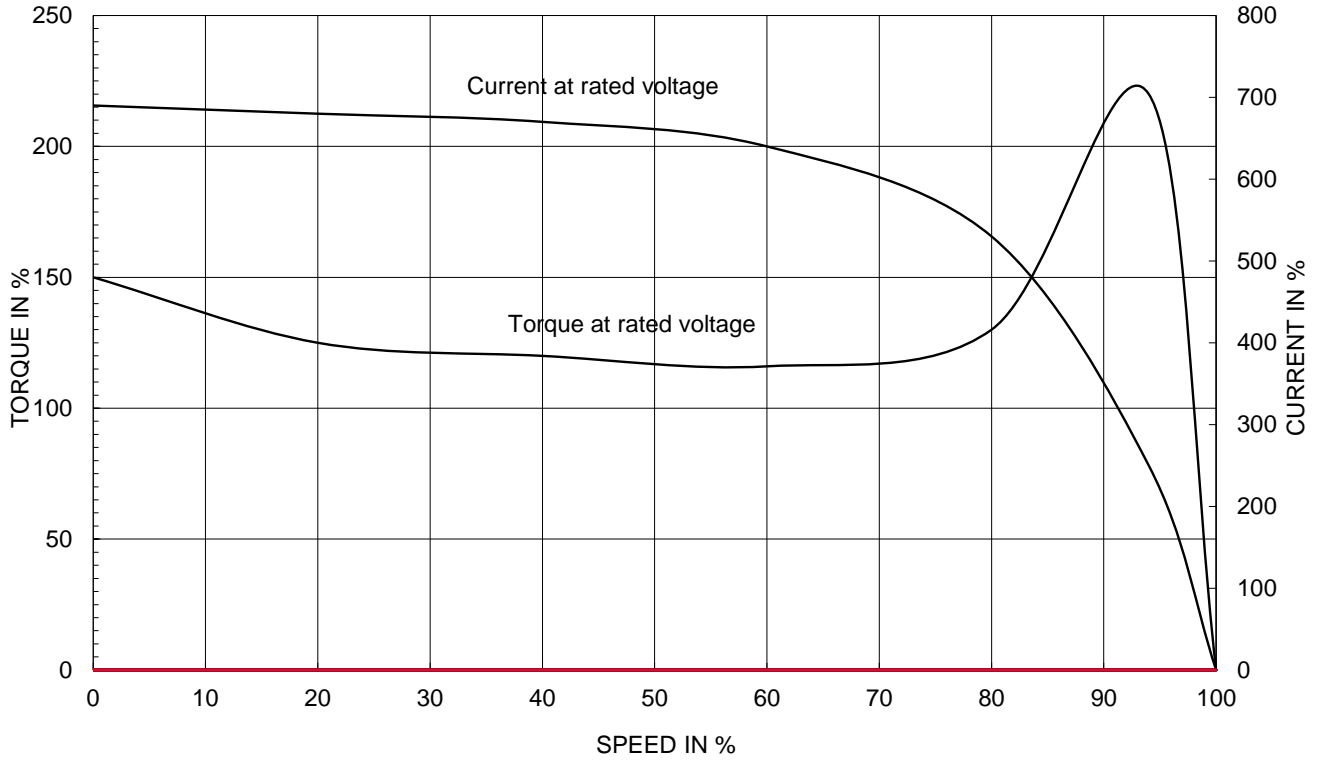

OUTPUT VS EFF., P.F & CURRENT CURVE

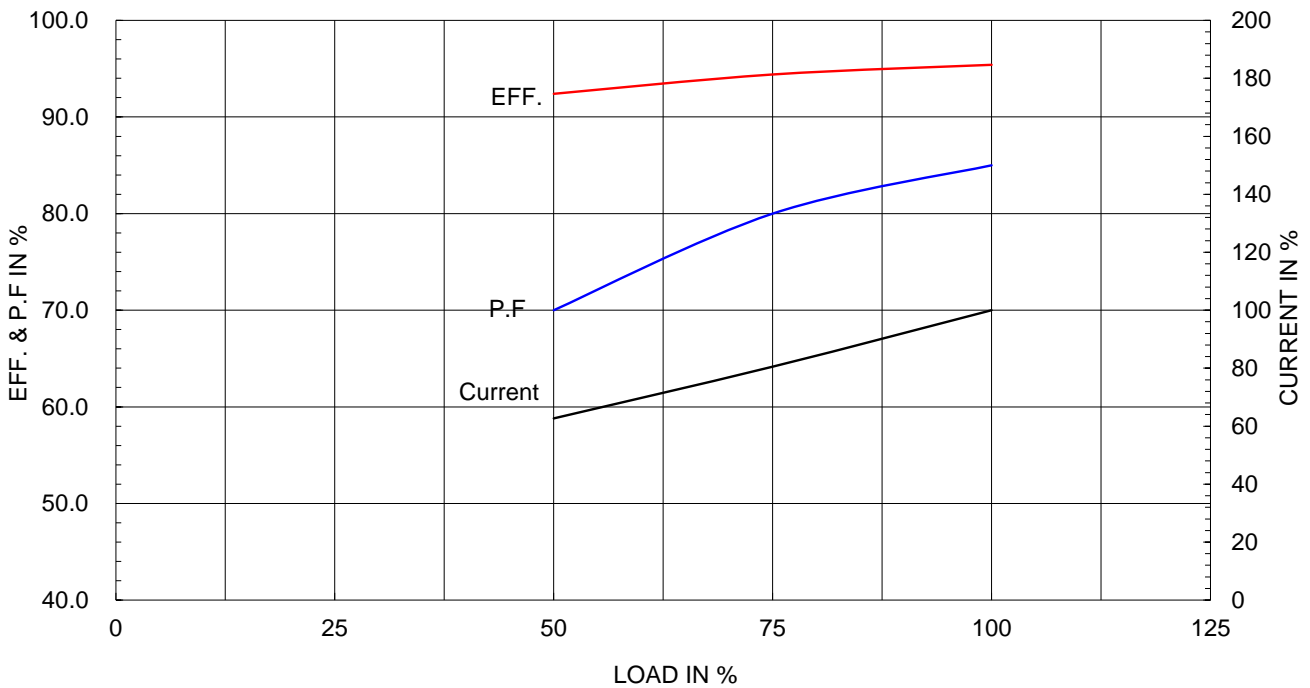

본 도면은 HD현대일렉트릭(주) 재산이며 허가없이 복사할 수 없음 (취급유의)

THIS DRAWING IS PROPRIETARY TO HYUNDAI ELECTRIC. NO PART OF THIS DRAWING MAY BE REPRODUCED WITHOUT THE PERMISSION OF HYUNDAI ELECTRIC.

1		2		3		4			
▽	50S	REV	DATE	CONTENTS		REVD BY	CHKD BY	CHKD BY	APPD BY
▽▽	12.5S								
▽▽▽	3.2S								
▽▽▽▽	0.4S								

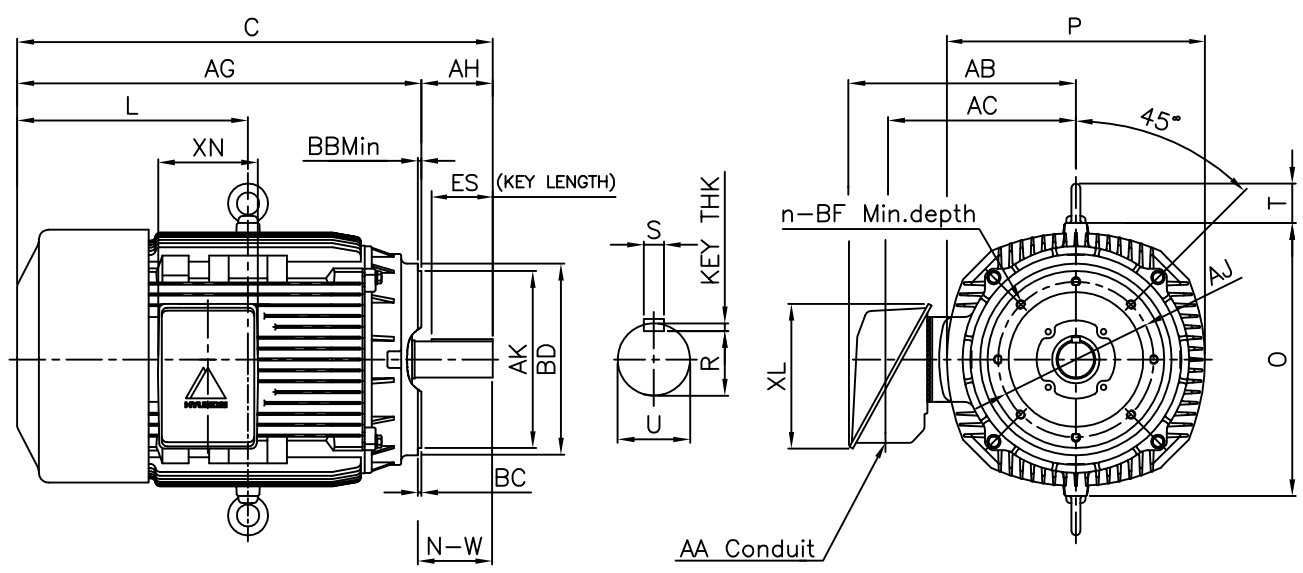

**DIMENSIONS**

Unit : inch

C - F A C E									CONDUIT BOX					APPROX. WGT.(LB)
AJ	AK	BB Min	BC	BD	BF	BF depth	n	AH	AA	AB	AC	XL	XN	
11.00	12.50	0.25	0.25	13.54	5/8-11	0.94	8	5.62	3.00	17.13	13.82	10.24	7.09	910

O V E R A L L						S H A F T					KEY	BEARING	
C	L	O	P	T	AG	U	N-W	KEYWAY			THK.	DRIVE END	OPP. DRIVE END
								R	ES	S			
34.01	16.13	19.29	17.75	2.80	28.13	2.375	5.88	2.021	4.28	0.625	0.625	6314C3	6213C3

**NOTE**

- 1.Dimension "U" tolerance : +0.000inch ~ -0.0005inch (143TC-215TC): +0.000inch ~ -0.001inch (254TC-449TC)
- 2.Dimension "R" tolerance : +0.000inch ~ - 0.015inch
- 3.Dimension "AK" tolerance : +0.000inch ~ -0.003inch (143TC-286TC): +0.000inch ~ -0.005inch (324TC-449TC)

APPD BY	S.K.HAN	UNIT	INCH	SUBJECT	NEMA 365TC	DWG SIZE	A4 ( 1:1 )
CHKD BY	S.Y.KIM	SCALE	NONE				
CHKD BY	Y.H.BAE	PROJEC'N	3각법(3rd Angle)	TITLE <b>OUTLINE</b>			
DSND BY	N.R.LEE	DATE	2019-06-03				



REF. NO	350A1514AA	Sheet No.	of
DWG NO	LM-T1365C5PL001	Revision No.	0

1	2	3	4
---	---	---	---



**HD HYUNDAI ELECTRIC**

본 도면은 HD현대일렉트릭(주) 재산이며 허가없이 복사할 수 없음 (취급주의)

THIS DRAWING IS PROPRIETARY TO HYUNDAI ELECTRIC. NO PART OF THIS DRAWING MAY BE REPRODUCED WITHOUT THE PERMISSION OF HYUNDAI ELECTRIC.

# Cls. I&II, Div. 2 IEEE 841

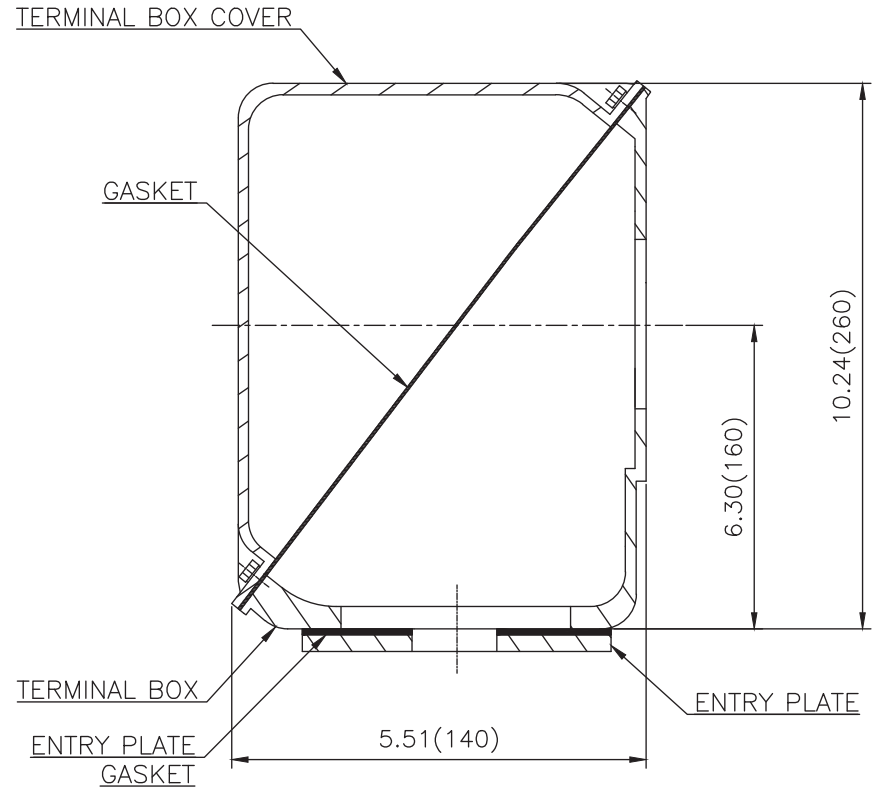
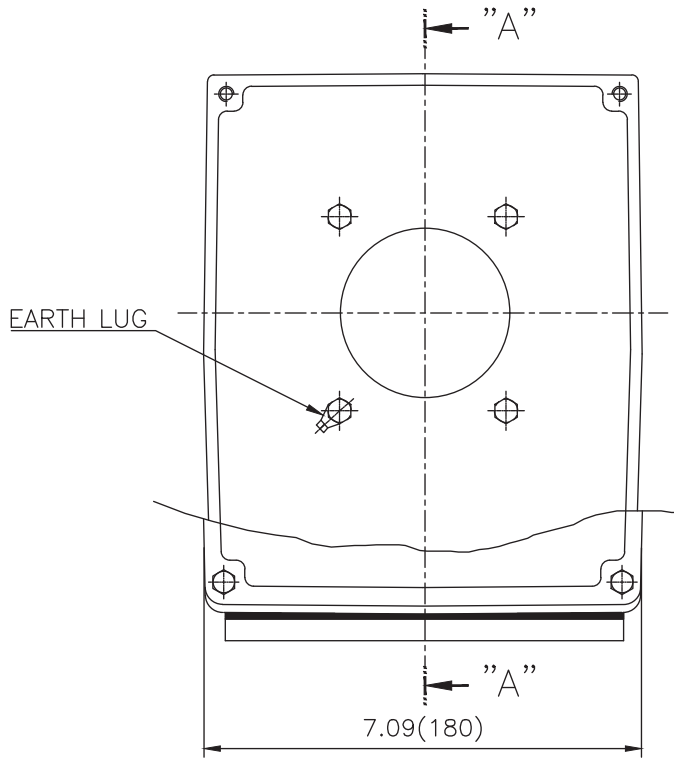

SEC. "A" - "A"

▽	50S
▽▽	12.5S
▽▽▽	3.2S
▽▽▽▽	0.4S

REV	DATE	CONTENTS	REVD BY	CHKD BY	CHKD BY	APPD BY

일반가공공차		일반계공공차	
1-4	±0.1	6-30	±0.5
4-18	±0.2	30-120	±0.8
18-63	±0.3	120-315	±1.2
63-250	±0.5	315-1000	±2.0
250-	±0.8	1000-	±3.0

Q'TY	DESCRIPTION	MATERIAL	DIMENSION	WEIGHT	PART NO.	REMARK	NO.
APPD BY	S.Y.KIM	UNIT	inch(mm)	SUBJECT	FR.360 (CAST IRON)	DWG SIZE	A3 (1:1.2)
CHKD BY		SCALE	1/1.2	TITLE			
CHKD BY	R.G.KIM	PROJEC'N	3rd Angle	MAIN TERMINAL BOX ASS'Y			
DSND BY	내승희	DATE	2023-10-19	REF. NO		Sheet No.	of
				DWG NO	3M-248450	Revision No.	0