

Customer :  
Project Name :  
Project No. :  
Revision No. :

# SPECIFICATION for INDUCTION MOTOR



0		For Bidding			
No.	DATE	DESCRIPTION	PREPARED BY	CHECKED BY	APPROVED BY



# AC INDUCTION MOTOR DATA SHEET

Catalog No.	HHI75-12-405T	Item No.	Rev. No. [     ]
Project Name		Project No.	Quantity                    sets

GENERAL SPECIFICATION		PERFORMANCE DATA				
Frame Size	405T	Rated Output	55 kW                    75 HP			
Type	PJP	Number of Poles	6			
Enclosure(Protection)	Totally Enclosed / IP55	Rotor Type	Squirrel Cage			
Method of Cooling	IC411(FC)	Starting Method*	D.O.L			
Rated Frequency	60 Hz	Rated Voltage	575 V	460 V	230 V	
Number of Phases	3	Current	Full Load	69.6 A	87.0 A                    173.9 A	
Insulation Class	F		Locked-rotor**	680 %	680 %                    680 %	
Temp. Rise at full load (by resistance method)		Efficiency				
at 1.0 S.F	80 deg. C	50% Load		91.5 %		
Motor Location	<input type="checkbox"/> Indoor <input type="checkbox"/> Outdoor	75% Load		93.5 %		
Altitude	Less than 1,000 meter	100% Load		94.5 %		
Relative Humidity	Less than 80 %	Power Factor(p.u)				
Ambient Temp.	40 deg. C (Max.)	50% Load		0.690		
Duty Type	Continuous ( S1 )	75% Load		0.790		
Service Factor	1.15	100% Load		0.840		
Mounting	B3	Speed at Full Load		1185 r.p.m		
Bearing	Type	Anti-Friction				
	DE/N-DE	NU316 / 6313C3				
	Lubricant	Grease(Polyrex-EM)				
External Thrust	Not applicable					
Coupling Method	<input checked="" type="checkbox"/> Direct <input type="checkbox"/> V-belt	Torque				
Shaft Extension	Single	Full Load		327.0 lb.ft		
Terminal Box	Main	Locked-rotor**		140 %		
	Aux.	Breakdown**		220 %		
Location	Refer to Outline Drawing	Moment of Inertia (J)				
Application		Load(Max.)		2,670.866 lb.ft2		
Area classification	Hazardous	Motor		55.310 lb.ft2		
Type of Ex-Protection	Class I&II, Division 2	Sound Pressure Level (No-load & mean value at 1m from motor)				
Applicable Standard	NEMA MG1, CSA C390			75 dB(A)		
ACCESSORIES		Vibration				3.8 mm/sec (peak)
		Permissible number of consecutive starts		Cold	3 times	
				Hot	2 times	
		Paint	Munsell No.	4.0PB5.4/5.5(VL-451)		
SPARE PARTS		SUBMITTAL DRAWING				
		Outline Dimension Drawing		Motor Weight(Approx.)		
		B3	LM-T1405B3PL001	1120 lb.		
REMARK		1. Premium efficiency according to NEMA MG1				
		2. Inverter Duty @ 1.0 Service Factor & F Temperature rise				
		- 10:1 VT (20:1 VT at 50% load)				
		- 10:1 CT				
		- CHP up to 1.5 times base speed, NEMA MG1 Part31				
REMARK		3. CSA Certification				
		- Class I, Division 2, Group A, B, C & D				
		- Class II, Division 2 Group E, F & G (Group E : up to 320Fr.)				
		4. Service Factor 1.15 and Temperature rise B are applicable under the condition of sine wave power.				
		5. Service Factor 1.25 is applicable to motors of 100HP or less with temperature rise F & Non-Hazardous.				
REMARK		Date	DSND	CHKD	CHKD	APPD
		2024-07-13	S.H. Lee	I.K. Kim	R.G. Kim	S.W. Kim

[Note] Others not mentioned in this data sheet shall be in accordance with maker standard.  
 Above technical data are only design values and shall be guaranteed with tolerance of applicable standard.  
 Inspection and performance test shall be done according to maker standard, if not mentioned.  
 \* In case of Inverter-Fed Motor, performance data is based on sine wave tests. It may be different from test data of Inverter combined motor.  
 \*\* Data is based on rated voltage & frequency and is expressed as a percentage of full-load value.

1	2	3	4
REV	DATE	CONTENTS	REVD BY   CHKD BY   CHKD BY   APPD BY

4.72

## CROWN TRITON

Premium Efficiency AC 3 Phase Motor

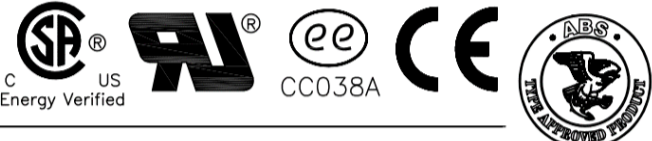

75HP	6P	230/460V	Cat. No.	HHI75-12-405T							
Model	HLS405SR06		INS. Class	F	HD-F1	Amps	173.9/87				
Type	HLS	Duty	CONT	Code	G	Amb.	40°C	Hertz	60Hz		
Frame	405T	Encl.	TEFC	S.F.	1.15	RPM	1185	NEMA Nom. Eff.	94.5%		
Bearing	Drive	NU316		S.F.1.00 (10:1 C.T., 20:1 V.T., NEMA-MG1 Part31)			3/4 Eff.	93.5%			
	Opp.	6313C3					NEMA Design	B			
Usable at	50Hz 75HP 380V 105.9A 981rpm S.F.: 1.0 Eff.: 93.3% Code: E										
	50Hz 75HP 400/415V 101/97.9A 983/984rpm S.F.: 1.0 Eff.: 93.6/93.8% Code: F/G										
CSA Certified for	Model	LATER		Type	PJP		Temp. Code	Frame	140~320FR	360~400FR	440FR
	CLASS I, Div. 2, Gr. A, B, C & D		CLASS II, Div. 2 Gr. E, F & G (Gr. E : Up to 320FR)			(sine wave)	Amb. 40°C	T3C (160°C)	T3B (165°C)	T3A (180°C)	T3A (180°C)
No.	-		Date	-		Weight	1120 lb				

4M-135702
Made in Korea H1

2.36

APPD BY	S.Y.KIM	UNIT	INCH	SUBJECT	CSA Class I, Division2 Severe Duty (HHI, 364-449)	DWG SIZE
CHKD BY	I.K.KIM	SCALE	NONE			A4 ( 1:1 )
CHKD BY	R.G.KIM	PROJEC'N	3rd Angle	TITLE <b>NAMEPLATE DRAWING</b>		
DSND BY	S.H.LEE	DATE	2024.06.07			
				REF. NO	<b>4M-135702</b>	Sheet No. of
				DWG NO	<b>NP-HHI75-12-405T</b>	Revision No. <b>0</b>

Type :	PJP	
Full Load Torque :	327.0	lb.ft
Load moment of Inertia (J) :	2670.866	lb.ft <sup>2</sup>
Motor moment of Inertia (J) :	55.310	lb.ft <sup>2</sup>

55kW	75HP	6 P	60 Hz
Speed at Full Load :			1185 RPM
Rated Voltage	575V	460V	230V
Full Load Current	69.6A	87.0A	173.9A

SPEED VS TORQUE & CURRENT CURVE

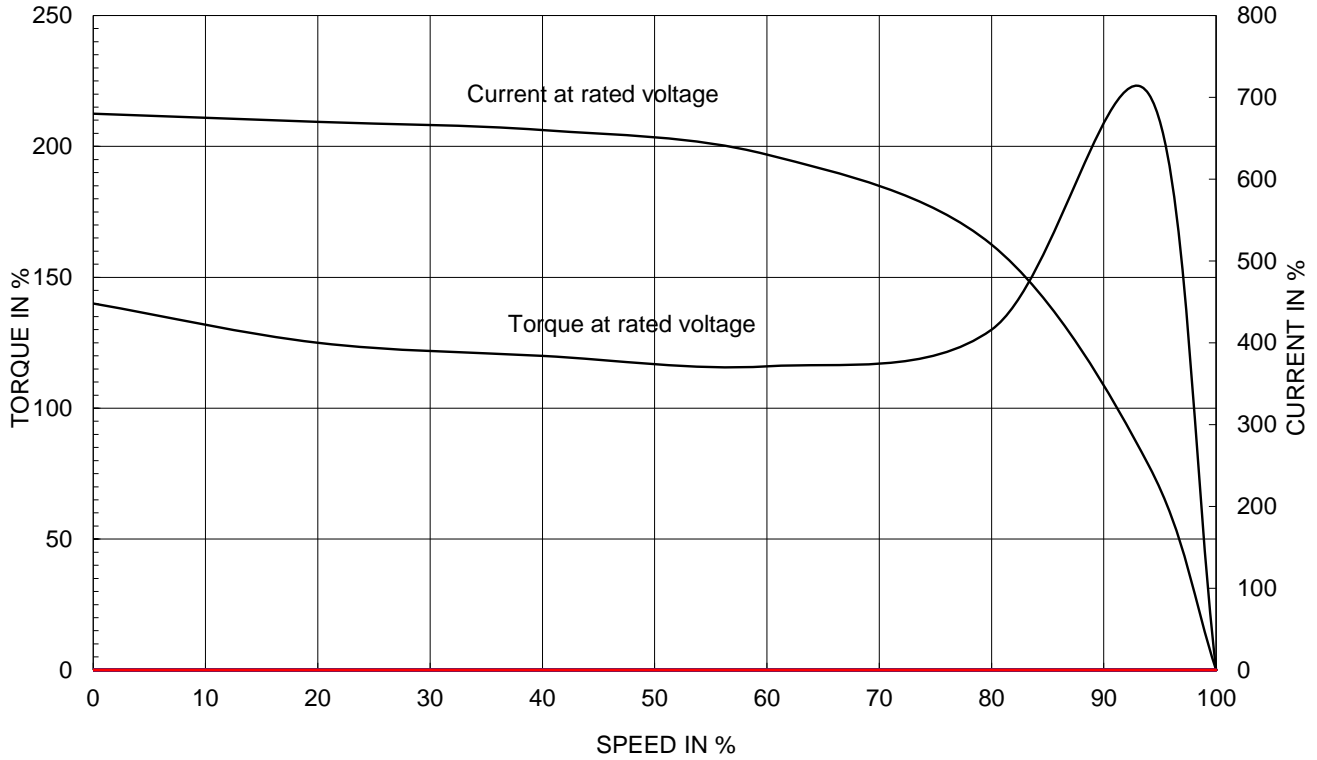

OUTPUT VS EFF., P.F & CURRENT CURVE

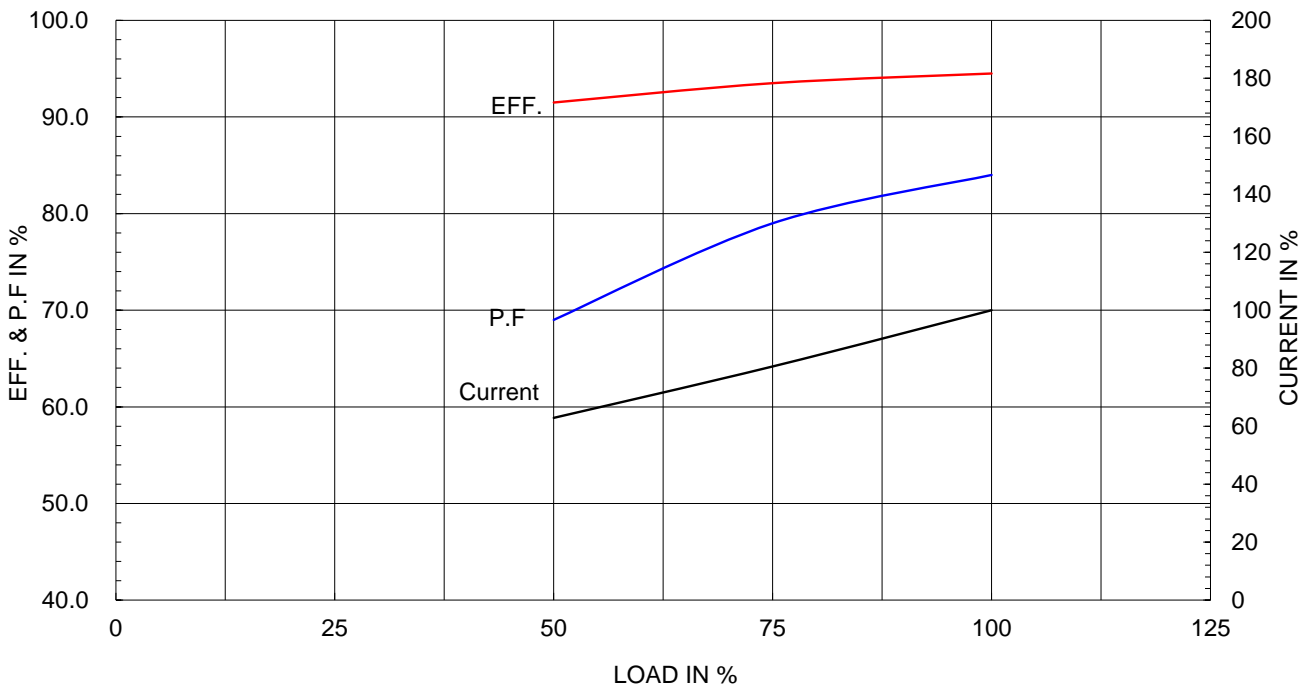

본 도면은 HD현대일렉트릭(주) 재산이며 허가없이 복사할 수 없음 (취급주의)

THIS DRAWING IS PROPRIETARY TO HYUNDAI ELECTRIC. NO PART OF THIS DRAWING MAY BE REPRODUCED WITHOUT THE PERMISSION OF HYUNDAI ELECTRIC.

▽	50S	REV	DATE	CONTENTS	REVD BY	CHKD BY	CHKD BY	APPD BY
▽▽	12.5S							
▽▽▽	3.2S							
▽▽▽▽	0.4S							

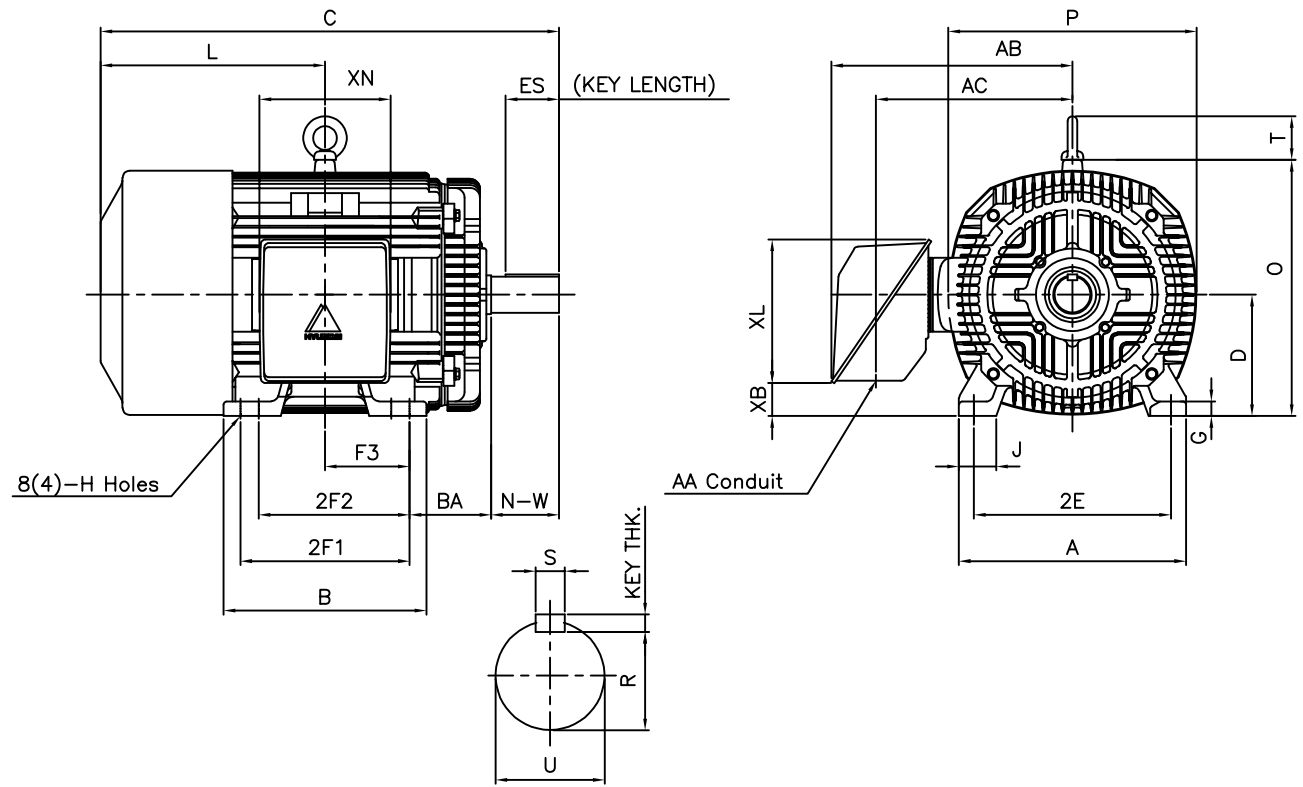

DIMENSIONS

unit : inch

M O U N T I N G									C O N D U I T B O X					APPROX. WGT.(LB)	
A	B	2E	2F1	2F2	F3	G	J	H	AA	AB	AC	XB	XL	XN	
18.43	16.46	16.00	13.75	(12.25)	6.870	1.18	3.03	0.81	3.00	20.28	14.85	2.83	11.65	10.63	1120

O V E R A L L							S H A F T					KEY	BEARING	
BA	C	D	L	O	P	T	U	N-W	KEYWAY			THK.	DRIVE END	OPP. DRIVE END
									R	ES	S			
6.62	39.42	10.00	18.68	20.79	20.16	3.55	2.875	7.25	2.450	5.65	0.750	0.750	6316C3 or NU316	6313C3

NOTE

1. Dimension "D" tolerance : +0.00inch - 0.03inch (143T-365T) ; +0.000inch - 0.06inch (404T-449T)
2. Dimension "U" tolerance : +0.000inch - 0.005inch (143T-215T), +0.000inch - 0.001inch (254T-449T)
3. Dimension "R" tolerance : +0.000inch - 0.015inch

APPD BY	S.K.HAN	UNIT	INCH	SUBJECT	405T	DWG SIZE	A4 ( 1:1 )
Q.P CHK	I.K.KIM	SCALE	NONE				
CHKD BY	R.G.KIM	PROJEC'N	3rd Angle	TITLE <b>OUTLINE</b>			
DSND BY	B.Y.KIM	DATE	2019.06.05				
				REF. NO	350A1116AA	Sheet No. of	
				DWG NO	LM-T1405B3PL001	Revision No. 0	

**Cls. I&II, Div. 2  
IEEE 841**



SEC. "A" - "A"

▽	50S
▽▽	12.5S
▽▽▽	3.2S
▽▽▽▽	0.4S

REV	DATE	CONTENTS	REVD BY	CHKD BY	CHKD BY	APPD BY

일반기준공차		일반재판공차	
1-4	±0.1	6-30	±0.5
4-18	±0.2	30-120	±0.8
18-63	±0.3	120-315	±1.2
63-250	±0.5	315-1000	±2.0
250-	±0.8	1000-	±3.0

Q'TY	DESCRIPTION	MATERIAL	DIMENSION	WEIGHT	PART NO.	REMARK	NO.
APPD BY	S.Y.KIM	UNIT	inch(mm)	SUBJECT	FR. 400-440 (CAST IRON)		DWG SIZE
CHKD BY		SCALE	1/1.2	TITLE	MAIN TERMINAL BOX ASS'Y		A3 (1:1.2)
CHKD BY	R.G.KIM	PROJEC'N	3rd Angle	DATE	2023-10-19		
DSND BY	배승희						
REF. NO		Sheet No.	of				
DWG NO	3M-248451	Revision No.	0				

