

Customer :
Project Name :
Project No. :
Revision No. :

SPECIFICATION for INDUCTION MOTOR



0		For Bidding			
No.	DATE	DESCRIPTION	PREPARED BY	CHECKED BY	APPROVED BY



AC INDUCTION MOTOR DATA SHEET

Catalog No.	HHI60-36-364TS	Item No.	Rev. No.	[]
Project Name		Project No.	Quantity	sets

GENERAL SPECIFICATION			PERFORMANCE DATA			
Frame Size	364TS		Rated Output	45 kW		60 HP
Type	PJP		Number of Poles	2		
Enclosure(Protection)	Totally Enclosed	/ IP55	Rotor Type	Squirrel Cage		
Method of Cooling	IC411(FC)		Starting Method*	D.O.L		
Rated Frequency	60 Hz		Rated Voltage	575 V	460 V	230 V
Number of Phases	3		Current	Full Load	52.5 A	65.6 A
Insulation Class	F			Locked-rotor**	680 %	680 %
Temp. Rise at full load (by resistance method)			Efficiency			
at 1.0 S.F	80 deg. C		50% Load		91.1 %	
Motor Location	<input type="checkbox"/> Indoor <input type="checkbox"/> Outdoor		75% Load		93.1 %	
Altitude	Less than 1,000 meter		100% Load		94.1 %	
Relative Humidity	Less than 80 %		Power Factor(p.u)			
Ambient Temp.	40 deg. C (Max.)		50% Load		0.765	
Duty Type	Continuous (S1)		75% Load		0.865	
Service Factor	1.15		100% Load		0.915	
Mounting	B3		Speed at Full Load	3570 r.p.m		
Bearing	Type	Anti-Friction	Torque			
	DE/N-DE	6213C3 / 6213C3	Full Load		88.8 lb.ft	
	Lubricant	Grease(Polyrex-EM)	Locked-rotor**		140 %	
External Thrust	Not applicable		Breakdown**		220 %	
Coupling Method	<input checked="" type="checkbox"/> Direct <input type="checkbox"/> V-belt		Moment of Inertia (J)			
Shaft Extension	Single		Load(Max.)		112.720 lb.ft2	
Terminal Box	Main	Cast Iron	Motor		9.280 lb.ft2	
	Aux.	No	Sound Pressure Level (No-load & mean value at 1m from motor)			
	Location	Refer to Outline Drawing	82 dB(A)			
Application			Vibration			
Area classification	Hazardous		3.8 mm/sec (peak)			
Type of Ex-Protection	Class I&II, Division 2		Permissible number of consecutive starts		Cold 3 times	
Applicable Standard	NEMA MG1, CSA C390		Hot		2 times	
	Paint	Munsell No.	4.0PB5.4/5.5(VL-451)			

ACCESSORIES

SPARE PARTS

SUBMITTAL DRAWING

Outline Dimension Drawing		Motor Weight(Approx.)	
B3	LM-T1364B3CL001	780 lb.	

REMARK

1. Premium efficiency according to NEMA MG1
2. Inverter Duty @ 1.0 Service Factor & F Temperature rise
 - 10:1 VT (20:1 VT at 50% load)
 - 10:1 CT
 - CHP up to 1.5 times base speed, NEMA MG1 Part31
3. CSA Certification
 - Class I, Division 2, Group A, B, C & D
 - Class II, Division 2 Group E, F & G (Group E : up to 320Fr.)
4. Service Factor 1.15 and Temperature rise B are applicable under the condition of sine wave power.
5. Service Factor 1.25 is applicable to motors of 100HP or less with temperature rise F & Non-Hazardous.

Date	DSND	CHKD	CHKD	APPD
2024-07-13	S.H. Lee	I.K. Kim	R.G. Kim	S.W. Kim





[Note] Others not mentioned in this data sheet shall be in accordance with maker standard.
 Above technical data are only design values and shall be guaranteed with tolerance of applicable standard.
 Inspection and performance test shall be done according to maker standard, if not mentioned.
 * In case of Inverter-Fed Motor, performance data is based on sine wave tests. It may be different from test data of Inverter combined motor.
 ** Data is based on rated voltage & frequency and is expressed as a percentage of full-load value.

1	2	3	4
REV	DATE	CONTENTS	REVD BY CHKD BY CHKD BY APPD BY

4.72



CROWN TRITON
Premium Efficiency AC 3 Phase Motor

60HP	2P	230/460V	Cat. No.	HHI60-36-364TS					
Model	HLS364SR02		INS. Class	F	HD-F1	Amps	131.2/65.		
Type	HLS	Duty	CONT	Code	G	Amb.	40°C	Hertz	60Hz
Frame	364TS	Encl.	TEFC	S.F.	1.15	RPM	3570	NEMA Nom. Eff.	94.1%
Bearing	Drive	6213C3		S.F.1.00 (10:1 C.T., 20:1 V.T., NEMA-MG1 Part31)			3/4 Eff.	93.1%	
	Opp.	6213C3					NEMA Design	B	
Usable at	50Hz 50HP 380V 65.6A 2968rpm S.F.: 1.0 Eff.: 93.7% Code: G								
	50Hz 50HP 400/415V 62.3/60.1A 2972/2975rpm S.F.: 1.0 Eff.: 93.9/94.1% Code: G/H								
CSA Certified for	Model	LATER		Type	PJP				
	CLASS I, Div. 2, Gr. A, B, C & D CLASS I, Zone 2, Gr. IIA, IIB, & IIC	CLASS II, Div. 2 Gr. E, F & G (Gr. E : Up to 320FR)		Temp. Code (sine wave)	Amb. 40°C	T3C (160°C)	T3B (165°C)	T3A (180°C)	
No.	-	Date	-	Frame	140~320FR	360~400FR	440FR		
	4M-135702		Made in Korea H1	Amb. 55°C	T3A (180°C)	T3A (180°C)	T3 (200°C)		
	MARINE DUTY IEEE45			Weight	780 lb				



2.36

APPD BY	S.Y.KIM	UNIT	INCH	SUBJECT	CSA Class I, Division2 Severe Duty (HHI, 364-449)	DWG SIZE
CHKD BY	I.K.KIM	SCALE	NONE			A4 (1:1)
CHKD BY	R.G.KIM	PROJEC'N	3rd Angle	TITLE NAMEPLATE DRAWING		
DSND BY	S.H.LEE	DATE	2024.06.07			
				REF. NO	4M-135702	Sheet No. of
				DWG NO	NP-HHI60-36-364TS	Revision No. 0

Type :	PJP
Full Load Torque :	88.8 lb.ft
Load moment of Inertia (J) :	112.720 lb.ft ²
Motor moment of Inertia (J) :	9.280 lb.ft ²

45kW 60HP	2 P	60 Hz
Speed at Full Load : 3570 RPM		
Rated Voltage	575V	460V 230V
Full Load Current	52.5A	65.6A 131.2A

SPEED VS TORQUE & CURRENT CURVE

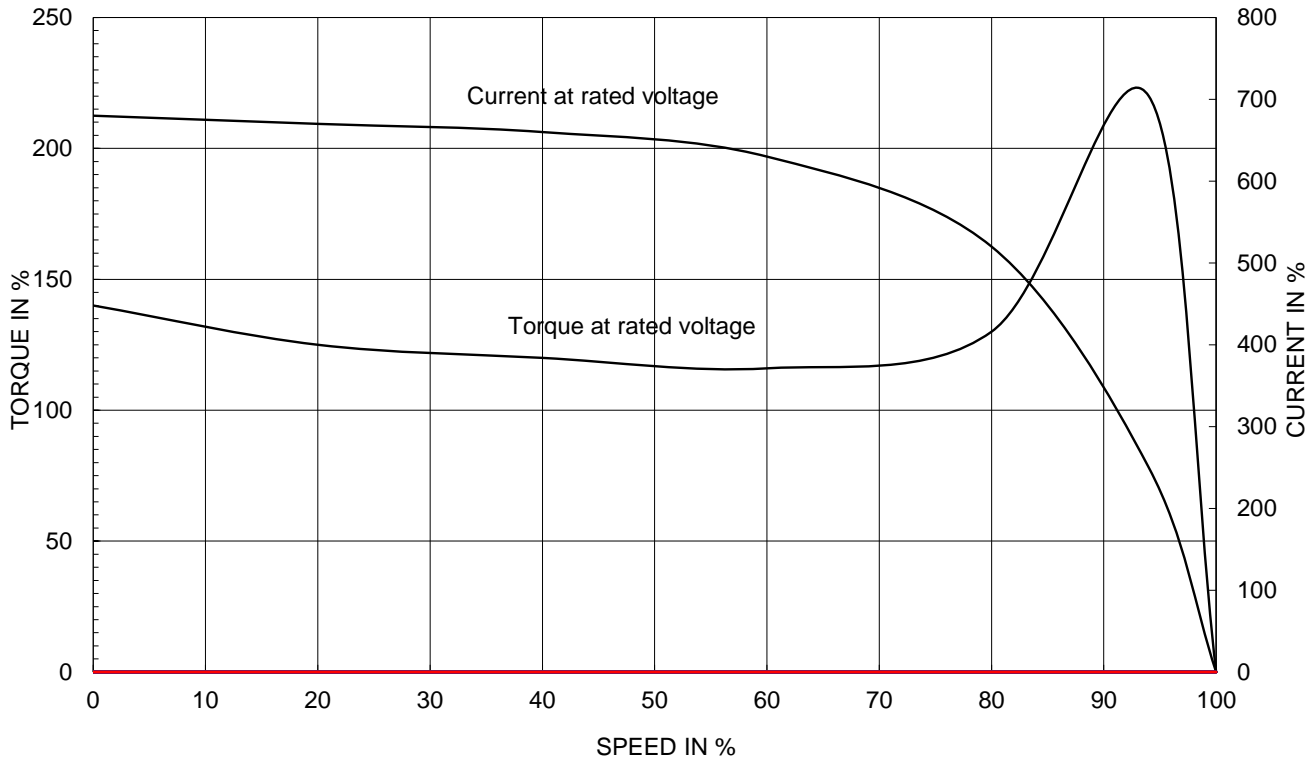

OUTPUT VS EFF., P.F & CURRENT CURVE

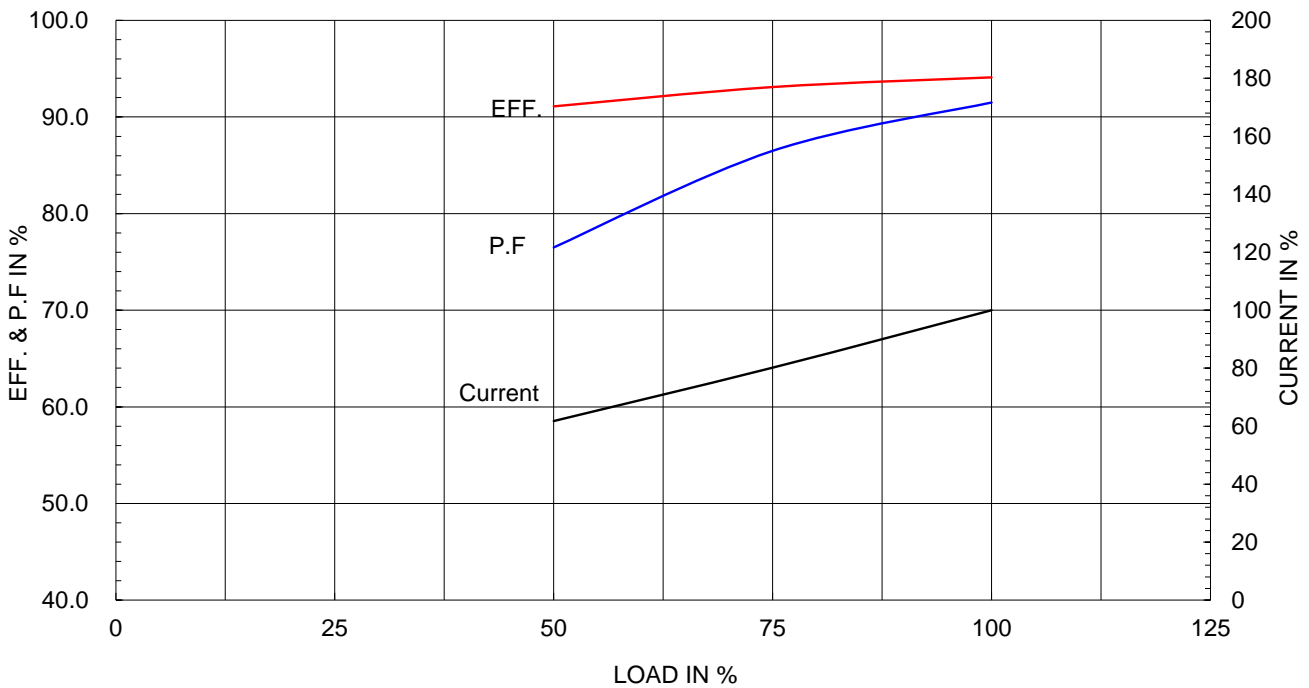

1		2		3		4			
▽	50S	REV	DATE	CONTENTS		REVD BY	CHKD BY	CHKD BY	APPD BY
▽▽	12.5S								
▽▽▽	3.2S								
▽▽▽▽	0.4S								

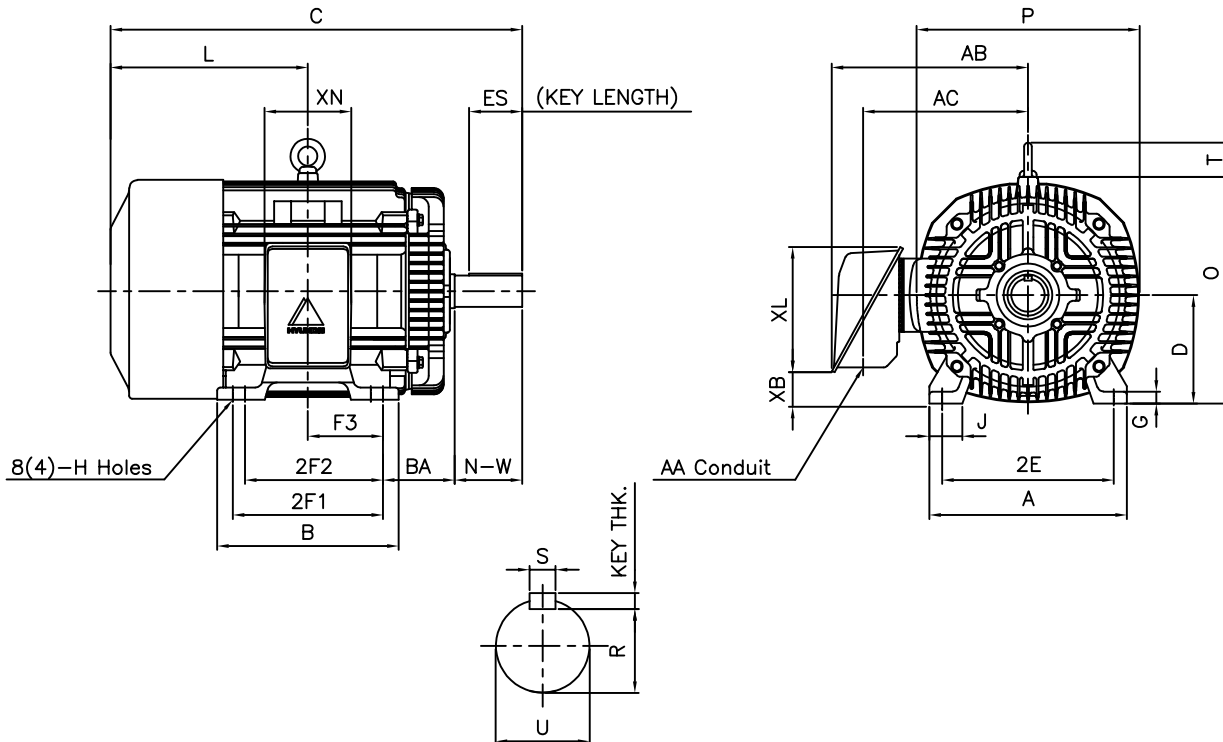

DIMENSIONS

unit : inch

M O U N T I N G									C O N D U I T B O X						APPROX. WGT.(LB)
A	B	2E	2F1	2F2	F3	G	J	H	AA	AB	AC	XB	XL	XN	
16.14	14.92	14.00	(12.25)	11.25	6.122	0.98	2.72	0.66	2.50	17.13	13.18	2.70	10.24	7.09	780

O V E R A L L							S H A F T				KEY	BEARING		
BA	C	D	L	O	P	T	U	N-W	KEYWAY			THK.	DRIVE END	OPP. DRIVE END
									R	ES	S			
5.88	31.88	9.00	16.13	18.50	18.23	2.80	1.875	3.75	1.591	2.03	0.500	0.500	6213C3	6213C3

NOTE

1. Dimension "D" tolerance : +0.00inch - 0.03inch (143T-365T) ; +0.000inch - 0.06inch (404T-449T)
2. Dimension "U" tolerance : +0.000inch - 0.005inch (143T-215T), +0.000inch - 0.001inch (254T-449T)
3. Dimension "R" tolerance : +0.000inch - 0.015inch

APPD BY	S.K.HAN	UNIT	INCH	SUBJECT	364TS	DWG SIZE	A4 (1:1)
Q.P CHK	I.K.KIM	SCALE	NONE				
CHKD BY	R.G.KIM	PROJEC'N	3rd Angle	TITLE OUTLINE			
DSND BY	B.Y.KIM	DATE	2019.06.05				
				REF. NO	350A1113BA	Sheet No.	of
				DWG NO	LM-T1364B3CL001	Revision No.	0



HD HYUNDAI ELECTRIC

본 도면은 HD현대일렉트릭(주) 재산이며 허가없이 복사할 수 없음 (취급주의)

THIS DRAWING IS PROPRIETARY TO HYUNDAI ELECTRIC. NO PART OF THIS DRAWING MAY BE REPRODUCED WITHOUT THE PERMISSION OF HYUNDAI ELECTRIC.

Cls. I&II, Div. 2 IEEE 841

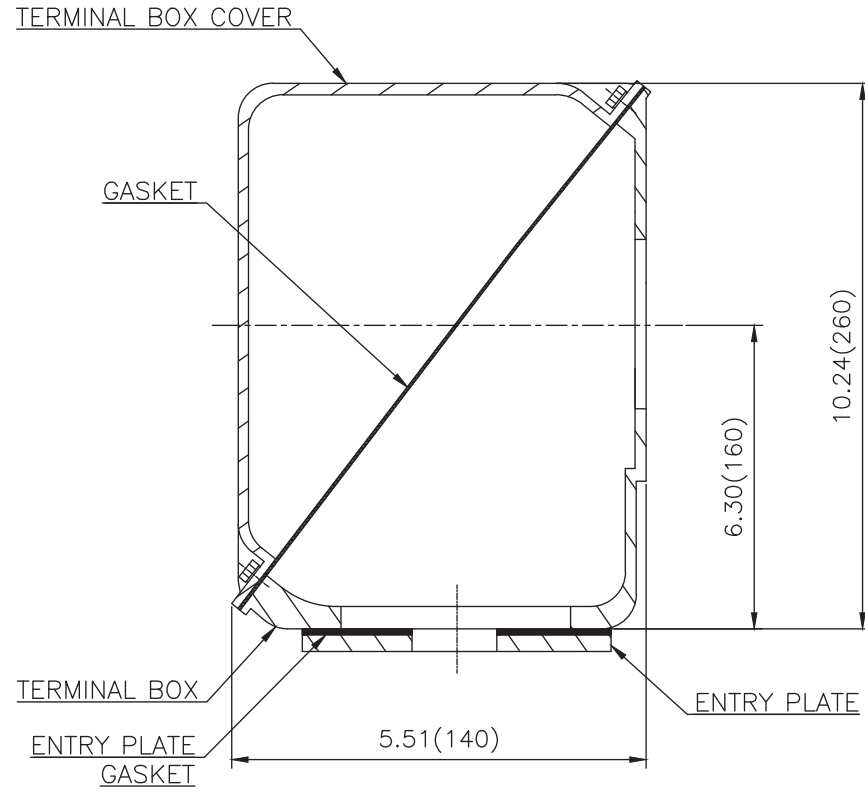
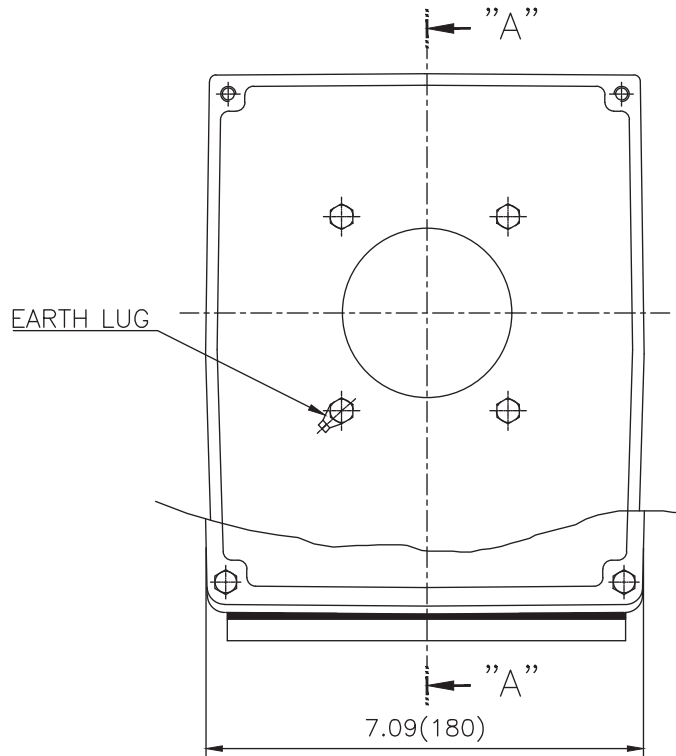

SEC. "A" - "A"

▽	50S
▽▽	12.5S
▽▽▽	3.2S
▽▽▽▽	0.4S

REV	DATE	CONTENTS	REVD BY	CHKD BY	CHKD BY	APPD BY

일반가공공차		일반계공공차	
1-4	±0.1	6-30	±0.5
4-18	±0.2	30-120	±0.8
18-63	±0.3	120-315	±1.2
63-250	±0.5	315-1000	±2.0
250-	±0.8	1000-	±3.0

Q'TY	DESCRIPTION	MATERIAL	DIMENSION	WEIGHT	PART NO.	REMARK	NO.
APPD BY	S.Y.KIM	UNIT	inch(mm)	SUBJECT	FR.360 (CAST IRON)	DWG SIZE	A3 (1:1.2)
CHKD BY		SCALE	1/1.2	TITLE			
CHKD BY	R.G.KIM	PROJEC'N	3rd Angle	MAIN TERMINAL BOX ASS'Y			
DSND BY	내승희	DATE	2023-10-19	REF. NO		Sheet No.	of
HD HYUNDAI ELECTRIC				DWG NO	3M-248450	Revision No.	0