

Customer :
Project Name :
Project No. :
Revision No. :

SPECIFICATION for INDUCTION MOTOR



0		For Bidding			
No.	DATE	DESCRIPTION	PREPARED BY	CHECKED BY	APPROVED BY



AC INDUCTION MOTOR DATA SHEET

Catalog No.	HHI60-18-364TCRD	Item No.	Rev. No.	[]
Project Name		Project No.	Quantity	sets

GENERAL SPECIFICATION		PERFORMANCE DATA				
Frame Size	364TC	Rated Output	45 kW 60 HP			
Type	PJP	Number of Poles	4			
Enclosure(Protection)	Totally Enclosed / IP55	Rotor Type	Squirrel Cage			
Method of Cooling	IC411(FC)	Starting Method*	D.O.L			
Rated Frequency	60 Hz	Rated Voltage	575 V	460 V	230 V	
Number of Phases	3	Current	Full Load	56.0 A	69.9 A	
Insulation Class	F		Locked-rotor**	670 %	670 %	670 %
Temp. Rise at full load (by resistance method)		Efficiency				
at 1.0 S.F	80 deg. C	50% Load		92.0 %		
Motor Location	<input type="checkbox"/> Indoor <input type="checkbox"/> Outdoor	75% Load		94.0 %		
Altitude	Less than 1,000 meter	100% Load		95.0 %		
Relative Humidity	Less than 80 %	Power Factor(p.u)				
Ambient Temp.	40 deg. C (Max.)	50% Load		0.700		
Duty Type	Continuous (S1)	75% Load		0.800		
Service Factor	1.15	100% Load		0.850		
Mounting	B5	Speed at Full Load	1780 r.p.m			
Bearing	Type	Anti-Friction				
	DE/N-DE	6314C3 / 6213C3				
	Lubricant	Grease(Polyrex-EM)				
External Thrust	Not applicable					
Coupling Method	<input checked="" type="checkbox"/> Direct <input type="checkbox"/> V-belt	Torque				
Shaft Extension	Single	Full Load		178.1 lb.ft		
Terminal Box	Main	Locked-rotor**		150 %		
	Aux.	Breakdown**		220 %		
Box Location	Refer to Outline Drawing	Moment of Inertia (J)				
Application		Load(Max.)		616.991 lb.ft2		
Area classification	Hazardous	Motor		17.640 lb.ft2		
Type of Ex-Protection	Class I&II, Division 2	Sound Pressure Level (No-load & mean value at 1m from motor)				
Applicable Standard	NEMA MG1, CSA C390			82 dB(A)		
ACCESSORIES		Vibration				3.8 mm/sec (peak)
		Permissible number of consecutive starts		Cold	3 times	
				Hot	2 times	
		Paint	Munsell No.	4.0PB5.4/5.5(VL-451)		
		SUBMITTAL DRAWING				
		Outline Dimension Drawing		Motor Weight(Approx.)		
		B5	LM-T1364C5PL001	870 lb.		
SPARE PARTS		REMARK				
		1. Premium efficiency according to NEMA MG1 2. Inverter Duty @ 1.0 Service Factor & F Temperature rise -. 10:1 VT (20:1 VT at 50% load) -. 10:1 CT -. CHP up to 1.5 times base speed, NEMA MG1 Part31 3. CSA Certification -. Class I, Division 2, Group A, B, C & D -. Class II, Division 2 Group E, F & G (Group E : up to 320Fr.) 4. Service Factor 1.15 and Temperature rise B are applicable under the condition of sine wave power. 5. Service Factor 1.25 is applicable to motors of 100HP or less with temperature rise F & Non-Hazardous.				
		Date	DSND	CHKD	CHKD	APPD
		2024-07-13	S.H. Lee	I.K. Kim	R.G. Kim	S.W. Kim

[Note] Others not mentioned in this data sheet shall be in accordance with maker standard.
 Above technical data are only design values and shall be guaranteed with tolerance of applicable standard.
 Inspection and performance test shall be done according to maker standard, if not mentioned.
 * In case of Inverter-Fed Motor, performance data is based on sine wave tests. It may be different from test data of Inverter combined motor.
 ** Data is based on rated voltage & frequency and is expressed as a percentage of full-load value.

1	2	3	4
REV	DATE	CONTENTS	REVD BY

4.72

CROWN TRITON
Premium Efficiency AC 3 Phase Motor



60HP	4P	230/460V	Cat. No.	HHI60-18-364TCRD			
Model	HLS364PR04		INS. Class	F	HD-F1	Amps	139.9/69.
Type	HLS	Duty	CONT	Code	G	Amb.	40°C
Hertz	60Hz						
Frame	364TC	Encl.	TEFC	S.F.	1.15	RPM	1780
			NEMA Nom. Eff.	95%			
Bearing	Drive	6314C3		S.F.1.00 (10:1 C.T., 20:1 V.T., NEMA-MG1 Part31)		3/4 Eff.	94%
	Opp.	6213C3				NEMA Design	B
Usable at	50Hz 60HP 380V 83.4A 1475rpm S.F.: 1.0 Eff.: 94.2% Code: E						
	50Hz 60HP 400/415V 80.7/79.4A 1478/1479rpm S.F.: 1.0 Eff.: 94.4/94.5% Code: F/G						
CSA Certified for	Model	LATER		Type	PJP		
	CLASS I, Div. 2, Gr. A, B, C & D	CLASS II, Div. 2 Gr. E, F & G (Gr. E : Up to 320FR)		Temp. Code (sine wave)	Amb. 40°C	T3C (160°C)	T3B (165°C)
	CLASS I, Zone 2, Gr. IIA, IIB, & IIC			Amb. 55°C	T3A (180°C)	T3A (180°C)	T3 (200°C)
No.	-		Date	-		Weight	870 lb

4M-135702
MARINE DUTY IEEE45

Made in Korea H1



2.36

APPD BY	S.Y.KIM	UNIT	INCH	SUBJECT	CSA Class I, Division2 Severe Duty (HHI, 364-449)	DWG SIZE
CHKD BY	I.K.KIM	SCALE	NONE			A4 (1:1)
CHKD BY	R.G.KIM	PROJEC'N	3rd Angle	TITLE NAMEPLATE DRAWING		
DSND BY	S.H.LEE	DATE	2024.06.07			
				REF. NO	4M-135702	Sheet No. of
				DWG NO	NP-HHI60-18-364TCRD	Revision No. 0

Type :	PJP
Full Load Torque :	178.1 lb.ft
Load moment of Inertia (J) :	616.991 lb.ft ²
Motor moment of Inertia (J) :	17.640 lb.ft ²

45kW 60HP	4 P	60 Hz
Speed at Full Load :		1780 RPM
Rated Voltage	575V	460V 230V
Full Load Current	56.0A	69.9A 139.9A

SPEED VS TORQUE & CURRENT CURVE

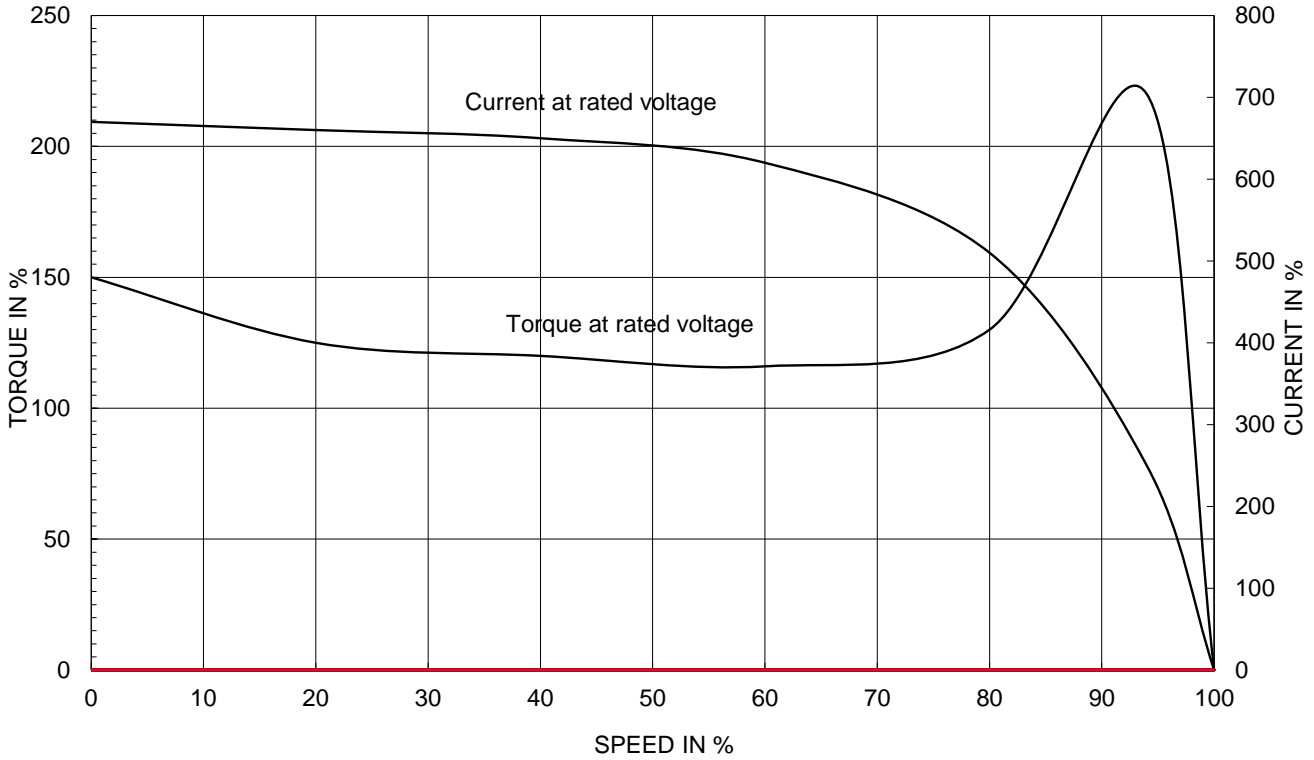

OUTPUT VS EFF., P.F & CURRENT CURVE

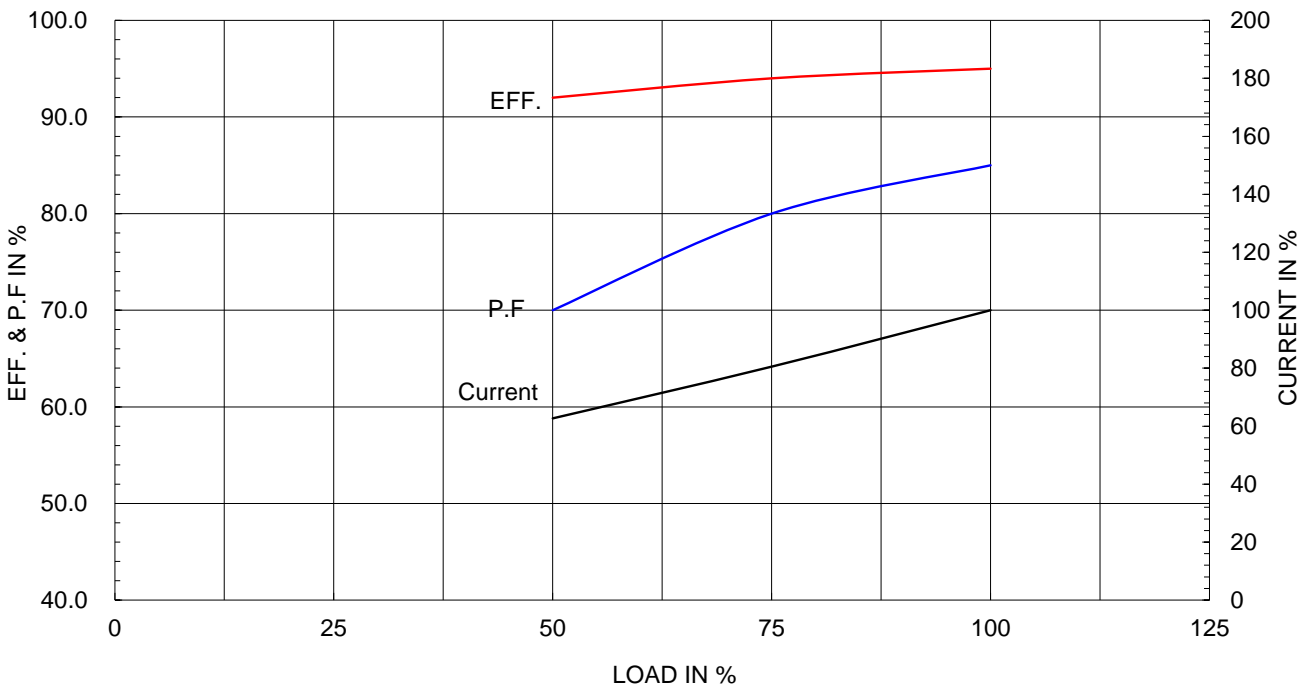

본 도면은 HD현대일렉트릭(주) 재산이며 허가없이 복사할 수 없음 (취급주의)

THIS DRAWING IS PROPRIETARY TO HYUNDAI ELECTRIC. NO PART OF THIS DRAWING MAY BE REPRODUCED WITHOUT THE PERMISSION OF HYUNDAI ELECTRIC.

1		2		3		4			
▽	50S	REV	DATE	CONTENTS		REVD BY	CHKD BY	CHKD BY	APPD BY
▽▽	12.5S								
▽▽▽	3.2S								
▽▽▽▽	0.4S								

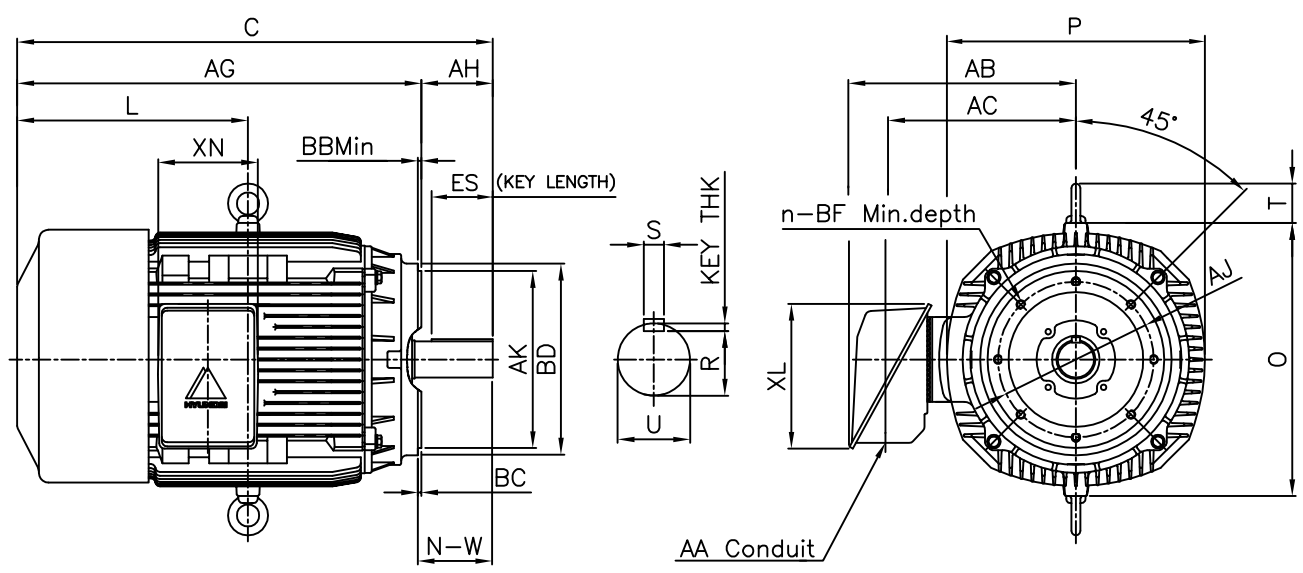

DIMENSIONS

Unit : inch

C - F A C E									CONDUIT BOX					APPROX. WGT.(LB)
AJ	AK	BB Min	BC	BD	BF	BF depth	n	AH	AA	AB	AC	XL	XN	
11.00	12.50	0.25	0.25	13.54	5/8-11	0.94	8	5.62	3.00	17.13	13.82	10.24	7.09	870

O V E R A L L						S H A F T					KEY	BEARING	
C	L	O	P	T	AG	U	N-W	KEYWAY			THK.	DRIVE END	OPP. DRIVE END
								R	ES	S			
34.01	16.13	19.29	17.75	2.80	28.13	2.375	5.88	2.021	4.28	0.625	0.625	6314C3	6213C3

NOTE

- 1.Dimension "U" tolerance : +0.000inch ~ -0.0005inch (143TC-215TC): +0.000inch ~ -0.001inch (254TC-449TC)
- 2.Dimension "R" tolerance : +0.000inch ~ - 0.015inch
- 3.Dimension "AK" tolerance : +0.000inch ~ -0.003inch (143TC-286TC): +0.000inch ~ -0.005inch (324TC-449TC)

APPD BY	S.K.HAN	UNIT	INCH	SUBJECT	NEMA 364TC	DWG SIZE
CHKD BY	S.Y.KIM	SCALE	NONE			A4 (1:1)
CHKD BY	Y.H.BAE	PROJEC'N	3각법(3rd Angle)	TITLE OUTLINE		
DSND BY	N.R.LEE	DATE	2019-06-03			



REF. NO	350A1513AA	Sheet No.	of
DWG NO	LM-T1364C5PL001	Revision No.	0

1	2	3	4
---	---	---	---



HD HYUNDAI ELECTRIC

본 도면은 HD현대일렉트릭(주) 재산이며 허가없이 복사할 수 없음 (취급주의)

THIS DRAWING IS PROPRIETARY TO HYUNDAI ELECTRIC. NO PART OF THIS DRAWING MAY BE REPRODUCED WITHOUT THE PERMISSION OF HYUNDAI ELECTRIC.

Cls. I&II, Div. 2 IEEE 841

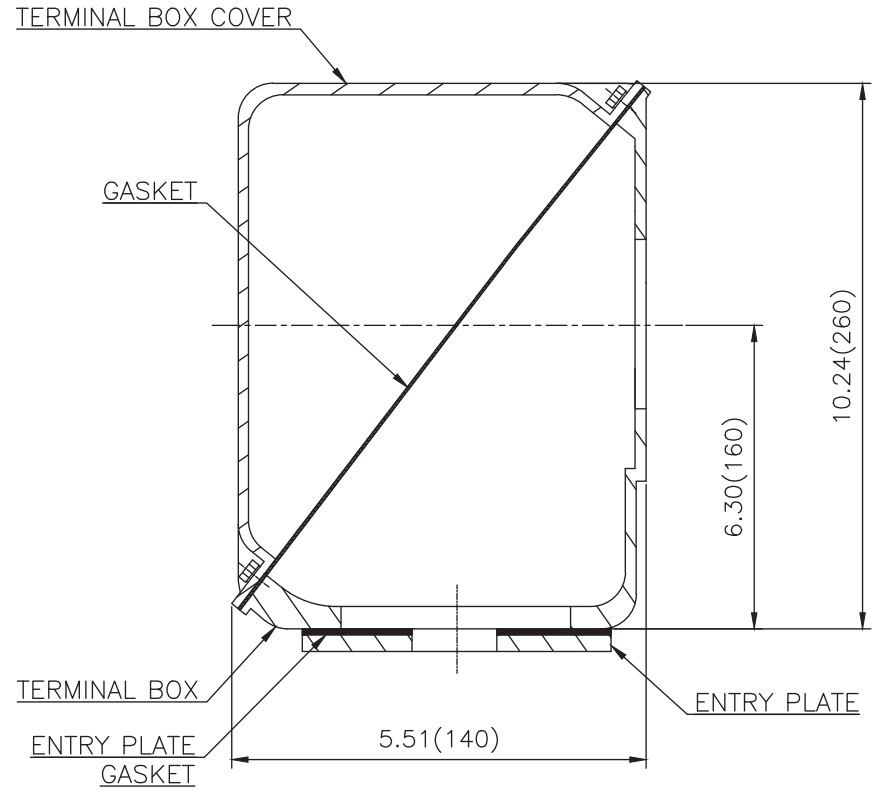
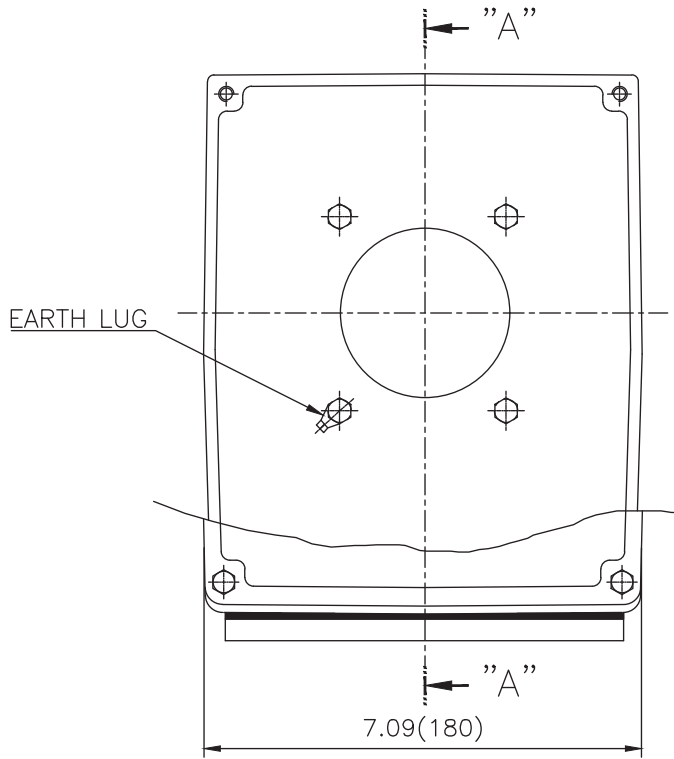

SEC. "A" - "A"

▽	50S
▽▽	12.5S
▽▽▽	3.2S
▽▽▽▽	0.4S

REV	DATE	CONTENTS	REVD BY	CHKD BY	CHKD BY	APPD BY

일반가공공차		일반계공공차	
1-4	±0.1	6-30	±0.5
4-18	±0.2	30-120	±0.8
18-63	±0.3	120-315	±1.2
63-250	±0.5	315-1000	±2.0
250-	±0.8	1000-	±3.0

Q'TY	DESCRIPTION	MATERIAL	DIMENSION	WEIGHT	PART NO.	REMARK	NO.
APPD BY	S.Y.KIM	UNIT	inch(mm)	SUBJECT	FR.360 (CAST IRON)	DWG SIZE	A3 (1:1.2)
CHKD BY		SCALE	1/1.2	TITLE			
CHKD BY	R.G.KIM	PROJEC'N	3rd Angle	MAIN TERMINAL BOX ASS'Y			
DSND BY	내승희	DATE	2023-10-19	REF. NO		Sheet No.	of
HD HYUNDAI ELECTRIC				DWG NO	3M-248450	Revision No.	0