

Customer :
Project Name :
Project No. :
Revision No. :

SPECIFICATION for INDUCTION MOTOR



| 0 | | For Bidding | | | |
|-----|------|-------------|-------------|------------|-------------|
| No. | DATE | DESCRIPTION | PREPARED BY | CHECKED BY | APPROVED BY |



AC INDUCTION MOTOR DATA SHEET

| | | | | | |
|--------------|---------------|-------------|--|----------|---------|
| Catalog No. | HHI50-12-365T | Item No. | | Rev. No. | [] |
| Project Name | | Project No. | | Quantity | sets |

| GENERAL SPECIFICATION | | | PERFORMANCE DATA | | | |
|--|--|--------------------------|--|------------------|------------------------------------|---------------------|
| Frame Size | 365T | | Rated Output | 37 kW 50 HP | | |
| Type | PJP | | Number of Poles | 6 | | |
| Enclosure(Protection) | Totally Enclosed / IP55 | | Rotor Type | Squirrel Cage | | |
| Method of Cooling | IC411(FC) | | Starting Method* | D.O.L | | |
| Rated Frequency | 60 Hz | | Rated Voltage | 575 V | 460 V | 230 V |
| Number of Phases | 3 | | Current | Full Load | 48.1 A | 60.2 A 120.4 A |
| Insulation Class | F | | | Locked-rotor** | 680 % | 680 % 680 % |
| Temp. Rise at full load (by resistance method) | | | Efficiency | | | |
| at 1.0 S.F | 80 deg. C | | 50% Load | | 91.1 % | |
| Motor Location | <input type="checkbox"/> Indoor <input type="checkbox"/> Outdoor | | 75% Load | | 93.1 % | |
| Altitude | Less than 1,000 meter | | 100% Load | | 94.1 % | |
| Relative Humidity | Less than 80 % | | Power Factor(p.u) | | | |
| Ambient Temp. | 40 deg. C (Max.) | | 50% Load | | 0.670 | |
| Duty Type | Continuous (S1) | | 75% Load | | 0.770 | |
| Service Factor | 1.15 | | 100% Load | | 0.820 | |
| Mounting | B3 | | Speed at Full Load | 1185 r.p.m | | |
| Bearing | Type | Anti-Friction | Torque | | | |
| | DE/N-DE | 6314C3 / 6213C3 | Full Load | | 220.0 lb.ft | |
| | Lubricant | Grease(Polyrex-EM) | Locked-rotor** | | 150 % | |
| External Thrust | Not applicable | | Breakdown** | | 220 % | |
| Coupling Method | <input checked="" type="checkbox"/> Direct <input type="checkbox"/> V-belt | | Moment of Inertia (J) | | | |
| Shaft Extension | Single | | Load(Max.) | | 1,500.593 lb.ft2 | |
| Terminal Box | Main | Cast Iron | Motor | | 32.000 lb.ft2 | |
| | Aux. | No | Sound Pressure Level (No-load & mean value at 1m from motor) | | | |
| | Location | Refer to Outline Drawing | | | 73 dB(A) | |
| Application | | | Vibration | | 3.8 mm/sec (peak) | |
| Area classification | Hazardous | | Permissible number of consecutive starts | | Cold 3 times Hot 2 times | |
| Type of Ex-Protection | Class I&II, Division 2 | | Paint | Munsell No. | 4.0PB5.4/5.5(VL-451) | |

ACCESSORIES

| | |
|--|--|
| | |
| | |
| | |
| | |
| | |
| | |

SPARE PARTS

| | |
|--|--|
| | |
| | |
| | |
| | |
| | |

SUBMITTAL DRAWING

| | | | |
|---------------------------|-----------------|-----------------------|--|
| Outline Dimension Drawing | | Motor Weight(Approx.) | |
| B3 | LM-T1365B3PL001 | 820 lb. | |
| | | | |
| | | | |

REMARK

1. Premium efficiency according to NEMA MG1
2. Inverter Duty @ 1.0 Service Factor & F Temperature rise
 - 10:1 VT (20:1 VT at 50% load)
 - 10:1 CT
 - CHP up to 1.5 times base speed, NEMA MG1 Part31
3. CSA Certification
 - Class I, Division 2, Group A, B, C & D
 - Class II, Division 2 Group E, F & G (Group E : up to 320Fr.)
4. Service Factor 1.15 and Temperature rise B are applicable under the condition of sine wave power.
5. Service Factor 1.25 is applicable to motors of 100HP or less with temperature rise F & Non-Hazardous.

| | | | | |
|------------|----------|----------|----------|----------|
| Date | DSND | CHKD | CHKD | APPD |
| 2024-07-13 | S.H. Lee | I.K. Kim | R.G. Kim | S.W. Kim |

[Note] Others not mentioned in this data sheet shall be in accordance with maker standard.
 Above technical data are only design values and shall be guaranteed with tolerance of applicable standard.
 Inspection and performance test shall be done according to maker standard, if not mentioned.
 * In case of Inverter-Fed Motor, performance data is based on sine wave tests. It may be different from test data of Inverter combined motor.
 ** Data is based on rated voltage & frequency and is expressed as a percentage of full-load value.

| | | | |
|-----|------|----------|---------------------------------------|
| 1 | 2 | 3 | 4 |
| REV | DATE | CONTENTS | REVD BY CHKD BY CHKD BY APPD BY |
| | | | |
| | | | |

4.72

CROWN TRITON

Premium Efficiency AC 3 Phase Motor

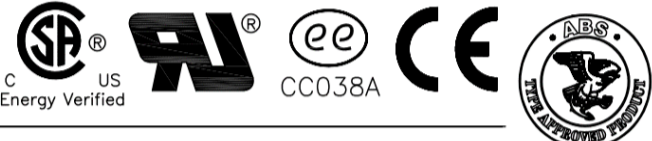

| | | | | | | | | | | | |
|--------------------------------------|---|-------------------------------|------------|--|-------------|-------------|-------------|----------------|-------------|-------------|------------|
| 50HP | 6P | 230/460V | Cat. No. | HHI50-12-365T | | | | | | | |
| Model | HLS365SR06 | | INS. Class | F | HD-F1 | Amps | 120.4/60. | | | | |
| Type | HLS | Duty | CONT | Code | H | Amb. | 40°C | Hertz | 60Hz | | |
| Frame | 365T | Encl. | TEFC | S.F. | 1.15 | RPM | 1185 | NEMA Nom. Eff. | 94.1% | | |
| Bearing | Drive | 6314C3 | | S.F.1.00 (10:1 C.T., 20:1 V.T., NEMA-MG1 Part31) | | | 3/4 Eff. | 93.1% | | | |
| | Opp. | 6213C3 | | | | | NEMA Design | B Torque | | | |
| Usable at | 50Hz 50HP 380V 72.5A 981rpm S.F.: 1.0 Eff.: 92.9% Code: F | | | | | | | | | | |
| | 50Hz 50HP 400/415V 69.6/68.1A 983/984rpm S.F.: 1.0 Eff.: 93.2/93.4% Code: G/H | | | | | | | | | | |
| CSA Certified for | Model | LATER | | Type | PJP | | Temp. Code | Frame | 140~320FR | 360~400FR | 440FR |
| | CLASS I, Div. 2, Gr. A, B, C & D | CLASS II, Div. 2 Gr. E, F & G | | (sine wave) | Amb. 40°C | T3C (160°C) | T3B (165°C) | T3A (180°C) | T3A (180°C) | T3A (180°C) | T3 (200°C) |
| CLASS I, Zone 2, Gr. IIA, IIB, & IIC | (Gr. E : Up to 320FR) | | Amb. 55°C | | T3A (180°C) | T3A (180°C) | T3A (180°C) | T3 (200°C) | T3 (200°C) | T3 (200°C) | |
| No. | - | Date | - | Weight | 820 lb | | | | | | |

4M-135702
Made in Korea H1

2.36

| | | | | | | |
|---|---------|----------|------------|-----------------------------------|---|-----------------------|
| APPD BY | S.Y.KIM | UNIT | INCH | SUBJECT | CSA Class I, Division2 Severe Duty (HHI, 364-449) | DWG SIZE |
| CHKD BY | I.K.KIM | SCALE | NONE | | | A4 (1:1) |
| CHKD BY | R.G.KIM | PROJEC'N | 3rd Angle | TITLE NAMEPLATE DRAWING | | |
| DSND BY | S.H.LEE | DATE | 2024.06.07 | | | |
|  | | | | REF. NO | 4M-135702 | Sheet No. of |
| | | | | DWG NO | NP-HHI50-12-365T | Revision No. 0 |

| | | |
|-------------------------------|----------|--------------------|
| Type : | PJP | |
| Full Load Torque : | 220.0 | lb.ft |
| Load moment of Inertia (J) : | 1500.593 | lb.ft ² |
| Motor moment of Inertia (J) : | 32.000 | lb.ft ² |

| | | | |
|----------------------|-------|-------|----------|
| 37kW | 50HP | 6 P | 60 Hz |
| Speed at Full Load : | | | 1185 RPM |
| Rated Voltage | 575V | 460V | 230V |
| Full Load Current | 48.1A | 60.2A | 120.4A |

SPEED VS TORQUE & CURRENT CURVE

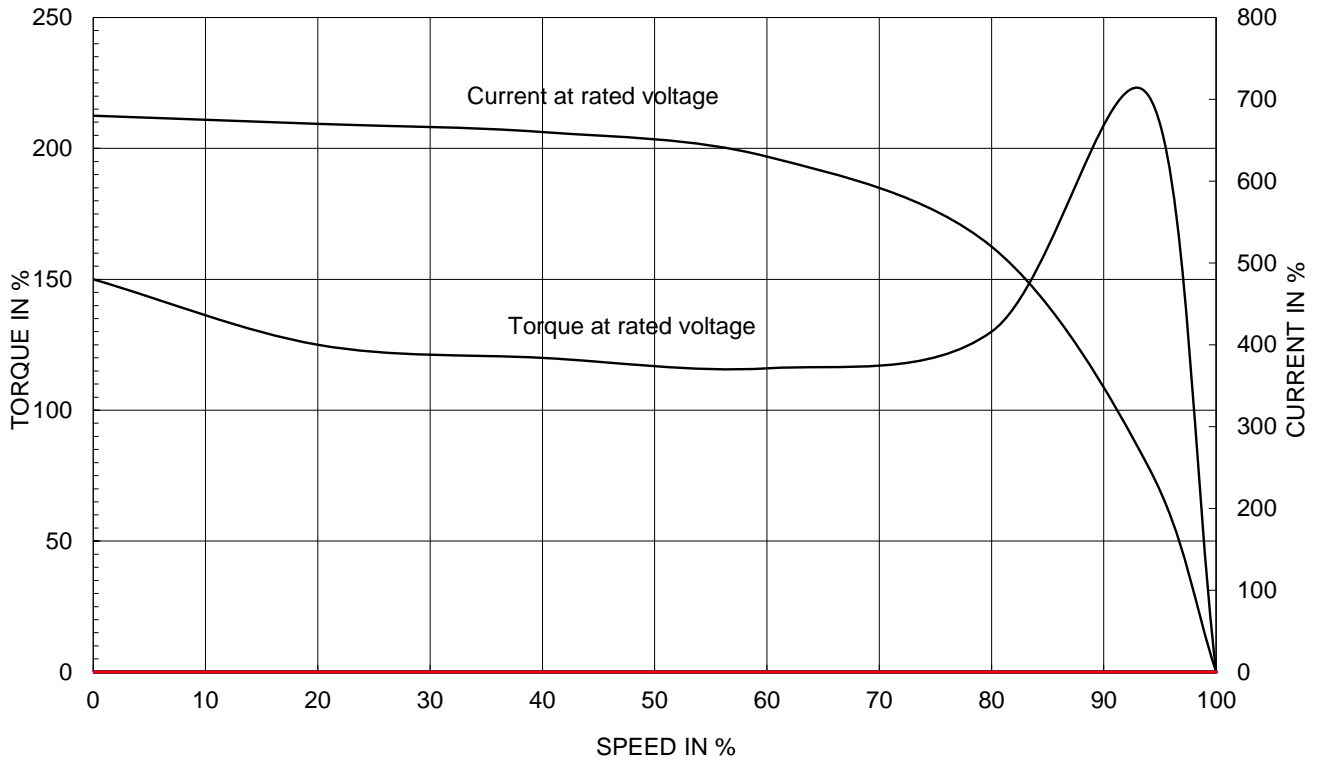

OUTPUT VS EFF., P.F & CURRENT CURVE

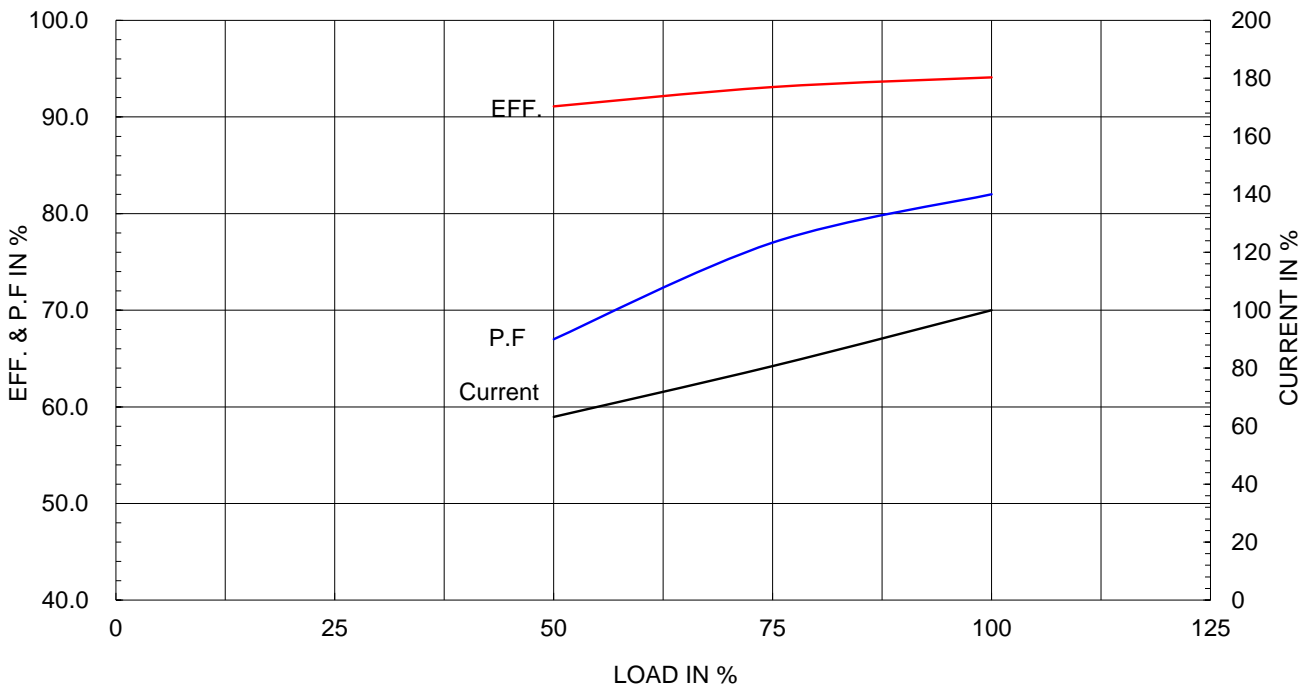

본 도면은 HD현대일렉트릭(주) 재산이며 허가없이 복사할 수 없음 (취급주의)

THIS DRAWING IS PROPRIETARY TO HYUNDAI ELECTRIC. NO PART OF THIS DRAWING MAYBE REPRODUCED WITHOUT THE PERMISSION OF HYUNDAI ELECTRIC.

| | | | |
|------|-------|-----|------|
| 1 | 2 | 3 | 4 |
| ▽ | 50S | REV | DATE |
| ▽▽ | 12.5S | | |
| ▽▽▽ | 3.2S | | |
| ▽▽▽▽ | 0.4S | | |

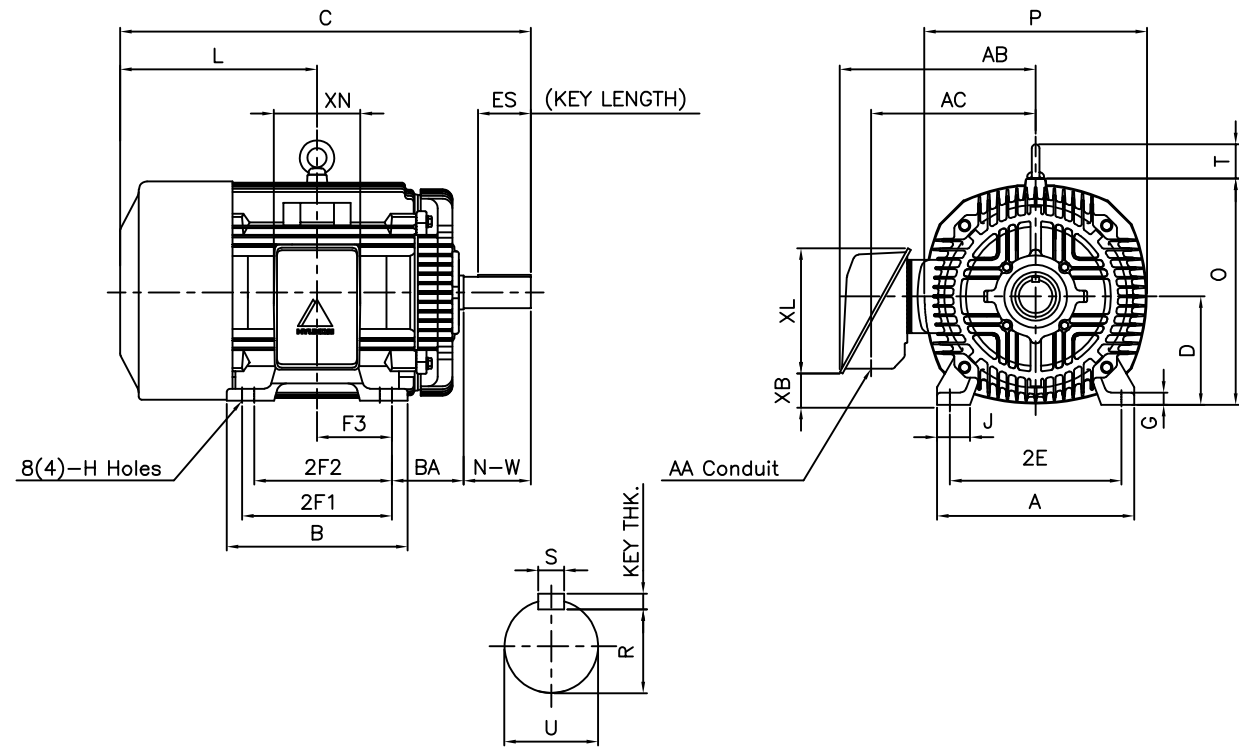

DIMENSIONS

unit : inch

| M O U N T I N G | | | | | | | | | C O N D U I T B O X | | | | | | APPROX. WGT.(LB) |
|-----------------|-------|-------|-------|---------|-------|------|------|------|---------------------|-------|-------|------|-------|------|------------------|
| A | B | 2E | 2F1 | 2F2 | F3 | G | J | H | AA | AB | AC | XB | XL | XN | |
| 16.14 | 14.92 | 14.00 | 12.25 | (11.25) | 6.122 | 0.98 | 2.72 | 0.66 | 3.00 | 17.13 | 13.82 | 2.70 | 10.24 | 7.09 | 820 |

| O V E R A L L | | | | | | | S H A F T | | | | | KEY | BEARING | |
|---------------|-------|------|-------|-------|-------|------|-----------|------|--------|------|-------|-------|-----------|----------------|
| BA | C | D | L | O | P | T | U | N-W | KEYWAY | | | THK. | DRIVE END | OPP. DRIVE END |
| | | | | | | | | | R | ES | S | | | |
| 5.88 | 34.01 | 9.00 | 16.13 | 18.50 | 18.23 | 2.80 | 2.375 | 5.88 | 2.021 | 4.28 | 0.625 | 0.625 | 6314C3 | 6213C3 |

NOTE

1. Dimension "D" tolerance : +0.00inch - 0.03inch (143T-365T) ; +0.000inch - 0.06inch (404T-449T)
2. Dimension "U" tolerance : +0.000inch - 0.005inch (143T-215T), +0.000inch - 0.001inch (254T-449T)
3. Dimension "R" tolerance : +0.000inch - 0.015inch

| | | | | | | | |
|----------|---------|----------|------------|-------------------------|-----------------|--------------|------------|
| APPD BY | S.K.HAN | UNIT | INCH | SUBJECT | 365T | DWG SIZE | A4 (1:1) |
| Q.P. CHK | I.K.KIM | SCALE | NONE | | | | |
| CHKD BY | R.G.KIM | PROJEC'N | 3rd Angle | TITLE OUTLINE | | | |
| DSND BY | B.Y.KIM | DATE | 2019.06.05 | | | | |
| | | | | REF. NO | 350A1114AA | Sheet No. | of |
| | | | | DWG NO | LM-T1365B3PL001 | Revision No. | 0 |



HD HYUNDAI ELECTRIC

본 도면은 HD현대일렉트릭(주) 재산이며 허가없이 복사할 수 없음 (취급주의)

THIS DRAWING IS PROPRIETARY TO HYUNDAI ELECTRIC. NO PART OF THIS DRAWING MAY BE REPRODUCED WITHOUT THE PERMISSION OF HYUNDAI ELECTRIC.

Cls. I&II, Div. 2 IEEE 841

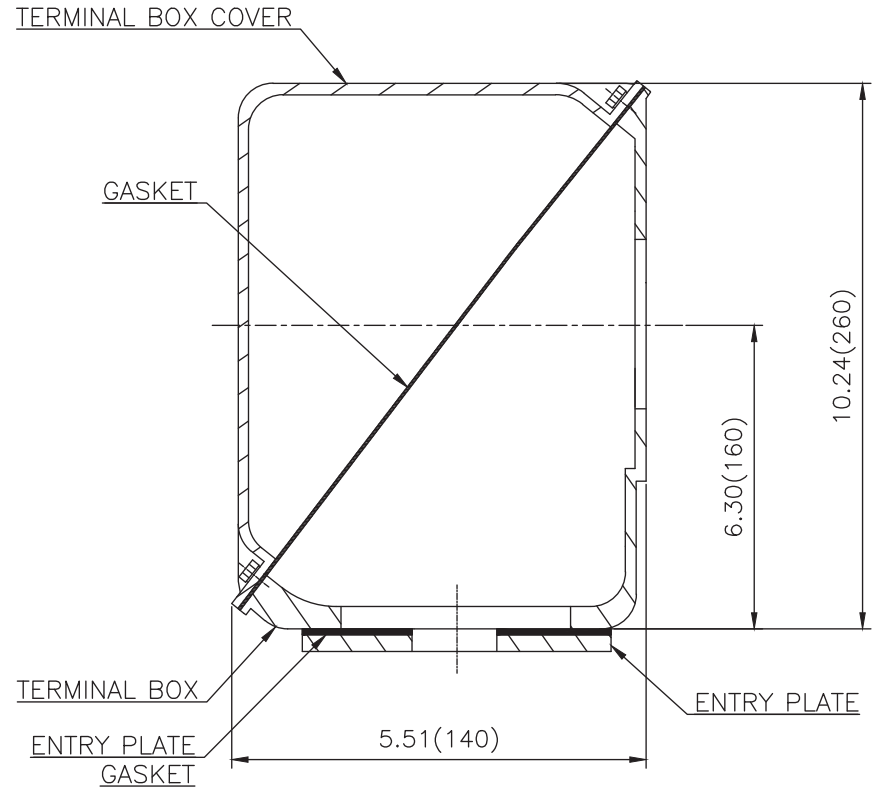
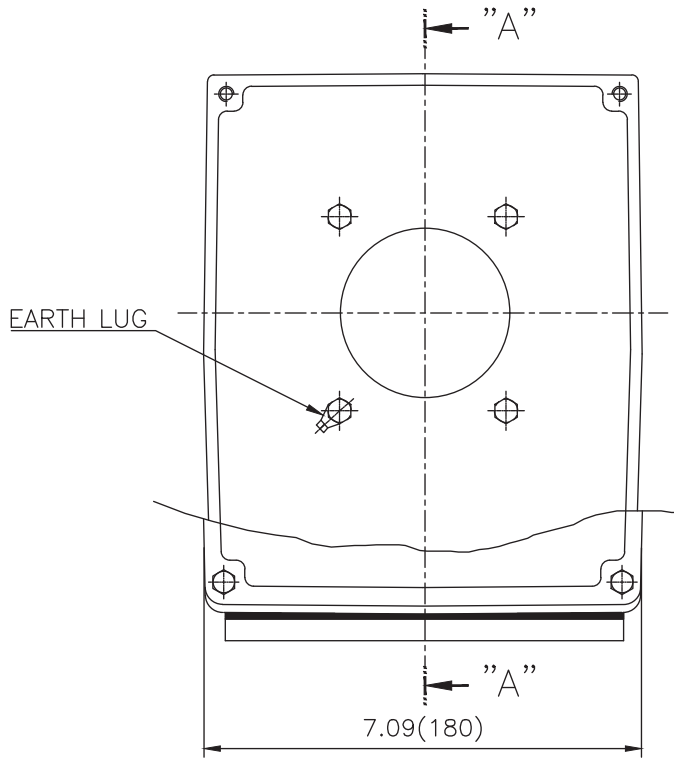

SEC. "A" - "A"

| | |
|------|-------|
| ▽ | 50S |
| ▽▽ | 12.5S |
| ▽▽▽ | 3.2S |
| ▽▽▽▽ | 0.4S |

| REV | DATE | CONTENTS | REVD BY | CHKD BY | CHKD BY | APPD BY |
|-----|------|----------|---------|---------|---------|---------|
| | | | | | | |

| 일반가공공차 | | 일반재공공차 | |
|--------|------|----------|------|
| 1-4 | ±0.1 | 6-30 | ±0.5 |
| 4-18 | ±0.2 | 30-120 | ±0.8 |
| 18-63 | ±0.3 | 120-315 | ±1.2 |
| 63-250 | ±0.5 | 315-1000 | ±2.0 |
| 250- | ±0.8 | 1000- | ±3.0 |

| Q'TY | DESCRIPTION | MATERIAL | DIMENSION | WEIGHT | PART NO. | REMARK | NO. |
|---------|-------------|----------|------------|-------------------------|--------------------|--------------|------------|
| APPD BY | S.Y.KIM | UNIT | inch(mm) | SUBJECT | FR.360 (CAST IRON) | DWG SIZE | A3 (1:1.2) |
| CHKD BY | | SCALE | 1/1.2 | TITLE | | | |
| CHKD BY | R.G.KIM | PROJEC'N | 3rd Angle | MAIN TERMINAL BOX ASS'Y | | | |
| DSND BY | 배승희 | DATE | 2023-10-19 | REF. NO | | Sheet No. | of |
| | | | | DWG NO | 3M-248450 | Revision No. | 0 |