

Customer :
Project Name :
Project No. :
Revision No. :

SPECIFICATION for INDUCTION MOTOR



0		For Bidding			
No.	DATE	DESCRIPTION	PREPARED BY	CHECKED BY	APPROVED BY



AC INDUCTION MOTOR DATA SHEET

Catalog No.	HHI200-36-447TS	Item No.	Rev. No.	[]
Project Name		Project No.	Quantity	sets

GENERAL SPECIFICATION		PERFORMANCE DATA				
Frame Size	447TS	Rated Output	150 kW 200 HP			
Type	PJP	Number of Poles	2			
Enclosure(Protection)	Totally Enclosed / IP55	Rotor Type	Squirrel Cage			
Method of Cooling	IC411(FC)	Starting Method*	D.O.L			
Rated Frequency	60 Hz	Rated Voltage	575 V	460 V	230 V	
Number of Phases	3	Current	Full Load	175.4 A	219.3 A	
Insulation Class	F		Locked-rotor**	700 %	700 %	700 %
Temp. Rise at full load (by resistance method)		Efficiency				
at 1.0 S.F	80 deg. C	50% Load		92.4 %		
Motor Location	<input type="checkbox"/> Indoor <input type="checkbox"/> Outdoor	75% Load		94.4 %		
Altitude	Less than 1,000 meter	100% Load		95.4 %		
Relative Humidity	Less than 80 %	Power Factor(p.u)				
Ambient Temp.	40 deg. C (Max.)	50% Load		0.750		
Duty Type	Continuous (S1)	75% Load		0.850		
Service Factor	1.15	100% Load		0.900		
Mounting	B3	Speed at Full Load	3570 r.p.m			
Bearing	Type	Anti-Friction				
	DE/N-DE	6314C3 / 6314C3				
	Lubricant	Grease(Polyrex-EM)				
External Thrust	Not applicable					
Coupling Method	<input checked="" type="checkbox"/> Direct <input type="checkbox"/> V-belt	Torque				
Shaft Extension	Single	Full Load		296.0 lb.ft		
Terminal Box	Main	Locked-rotor**		120 %		
	Aux.	Breakdown**		220 %		
Box Location	Refer to Outline Drawing	Moment of Inertia (J)				
Application		Load(Max.)		341.126 lb.ft2		
Area classification	Hazardous	Motor		44.130 lb.ft2		
Type of Ex-Protection	Class I&II, Division 2	Sound Pressure Level (No-load & mean value at 1m from motor)				
Applicable Standard	NEMA MG1, CSA C390	92 dB(A)				
ACCESSORIES		Vibration				3.8 mm/sec (peak)
		Permissible number of consecutive starts		Cold	3 times	
				Hot	2 times	
		Paint	Munsell No.	4.0PB5.4/5.5(VL-451)		
SPARE PARTS		SUBMITTAL DRAWING				
		Outline Dimension Drawing		Motor Weight(Approx.)		
		B3	LM-T1447B3CL001	1900 lb.		
REMARK		<ol style="list-style-type: none"> 1. Premium efficiency according to NEMA MG1 2. Inverter Duty @ 1.0 Service Factor & F Temperature rise <ul style="list-style-type: none"> - 10:1 VT (20:1 VT at 50% load) - 10:1 CT - CHP up to 1.5 times base speed, NEMA MG1 Part31 3. CSA Certification <ul style="list-style-type: none"> - Class I, Division 2, Group A, B, C & D - Class II, Division 2 Group E, F & G (Group E : up to 320Fr.) 4. Service Factor 1.15 and Temperature rise B are applicable under the condition of sine wave power. 5. Service Factor 1.25 is applicable to motors of 100HP or less with temperature rise F & Non-Hazardous. 				
		Date	DSND	CHKD	CHKD	APPD
		2024-07-13	S.H. Lee	I.K. Kim	R.G. Kim	S.W. Kim

[Note] Others not mentioned in this data sheet shall be in accordance with maker standard.
 Above technical data are only design values and shall be guaranteed with tolerance of applicable standard.
 Inspection and performance test shall be done according to maker standard, if not mentioned.
 * In case of Inverter-Fed Motor, performance data is based on sine wave tests. It may be different from test data of Inverter combined motor.
 ** Data is based on rated voltage & frequency and is expressed as a percentage of full-load value.

1	2	3	4
REV	DATE	CONTENTS	REVD BY CHKD BY CHKD BY APPD BY

4.72

CROWN TRITON

Premium Efficiency AC 3 Phase Motor

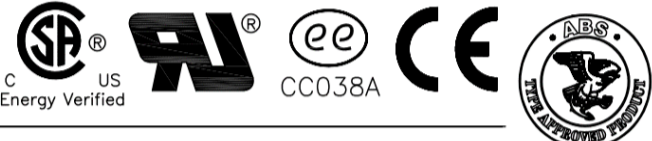

200HP	2P	460V	Cat. No.	HHI200-36-447TS							
Model	HLS447SR02		INS. Class	F	HD-F1	Amps	219.3				
Type	HLS	Duty	CONT	Code	G	Amb.	40°C	Hertz	60Hz		
Frame	447TS	Encl.	TEFC	S.F.	1.15	RPM	3570	NEMA Nom. Eff.	95.4%		
Bearing	Drive	6314C3		S.F.1.00 (10:1 C.T., 20:1 V.T., NEMA-MG1 Part31)			3/4 Eff.	94.4%			
	Opp.	6314C3					NEMA Design	B			
Usable at	50Hz 200HP 380V 267.2A 2962rpm S.F.: 1.0 Eff.: 95.1% Code: E										
	50Hz 200HP 400/415V 253/243.9A 2966/2969rpm S.F.: 1.0 Eff.: 95.3/95.4% Code: F/G										
CSA Certified for	Model	LATER		Type	PJP		Temp. Code	Frame	140~320FR	360~400FR	440FR
	CLASS I, Div. 2, Gr. A, B, C & D	CLASS II, Div. 2 Gr. E, F & G		(Gr. E : Up to 320FR)	(sine wave)	Amb. 40°C	T3C (160°C)	T3B (165°C)	T3A (180°C)	T3A (180°C)	T3 (200°C)
No.	-	Date	-	Weight	1900 lb						

4M-135702 Made in Korea H1 

2.36

APPD BY	S.Y.KIM	UNIT	INCH	SUBJECT	CSA Class I, Division2 Severe Duty (HHI, 364-449)	DWG SIZE
CHKD BY	I.K.KIM	SCALE	NONE			A4 (1:1)
CHKD BY	R.G.KIM	PROJEC'N	3rd Angle	TITLE NAMEPLATE DRAWING		
DSND BY	S.H.LEE	DATE	2024.06.07			
				REF. NO	4M-135702	Sheet No. of
				DWG NO	NP-HHI200-36-447TS	Revision No. 0

Type :	PJP
Full Load Torque :	296.0 lb.ft
Load moment of Inertia (J) :	341.126 lb.ft2
Motor moment of Inertia (J) :	44.130 lb.ft2

150kW	200HP	2 P	60 Hz
Speed at Full Load :			3570 RPM
Rated Voltage	575V	460V	230V
Full Load Current	175.4A	219.3A	438.5A

SPEED VS TORQUE & CURRENT CURVE

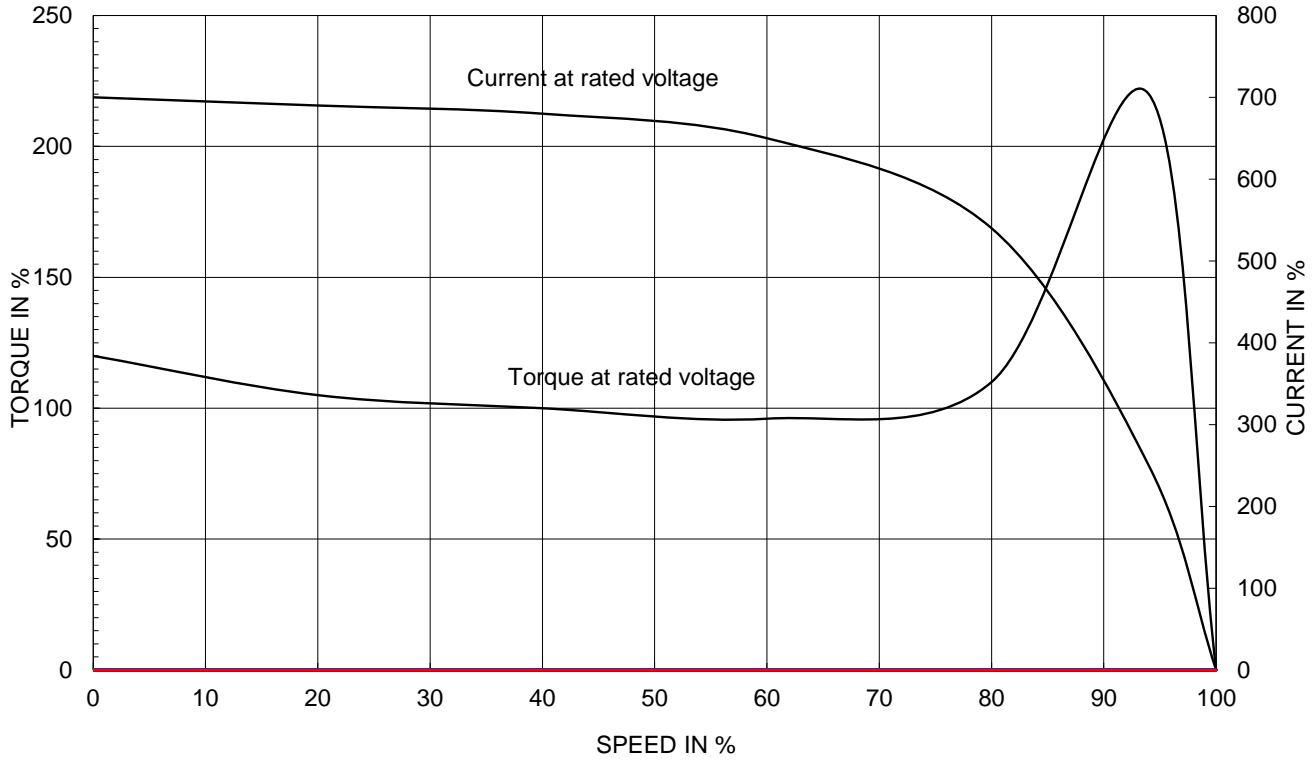

OUTPUT VS EFF., P.F & CURRENT CURVE

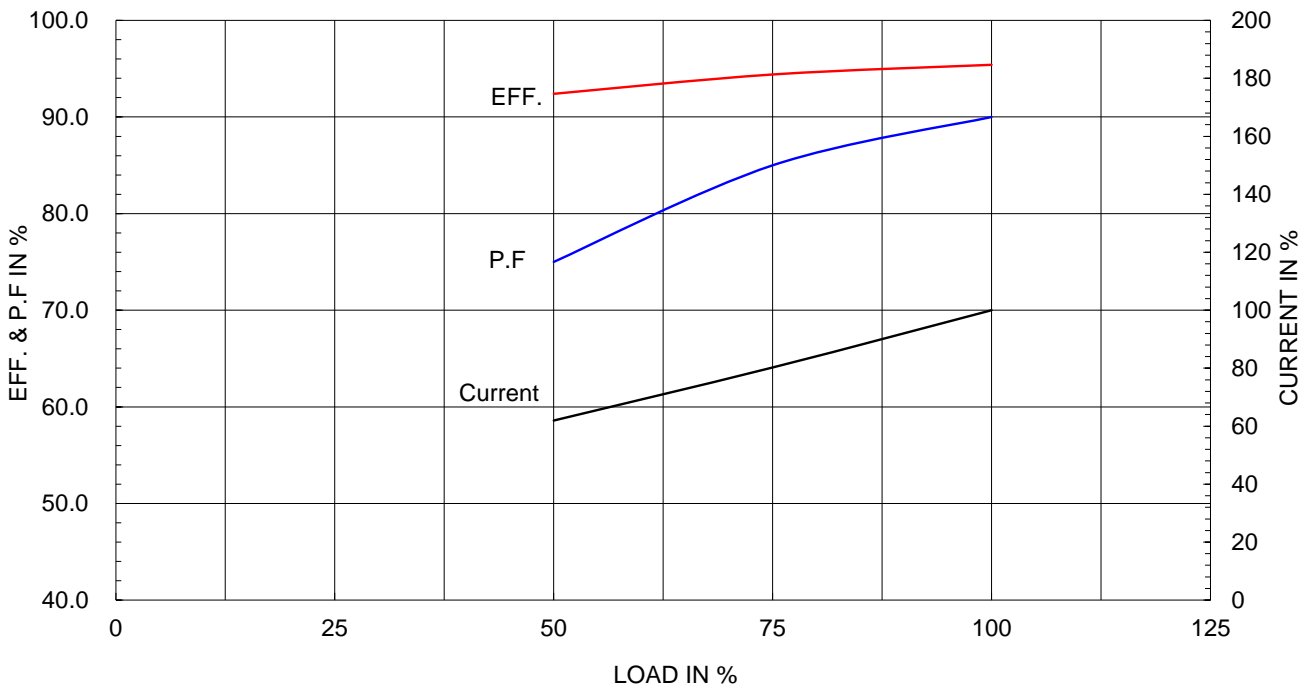

본 도면은 HD현대일렉트릭(주) 재산이며 허가없이 복사할 수 없음 (취급주의)

THIS DRAWING IS PROPRIETARY TO HYUNDAI ELECTRIC. NO PART OF THIS DRAWING MAYBE REPRODUCED WITHOUT THE PERMISSION OF HYUNDAI ELECTRIC.

1		2		3		4			
▽	50S	REV	DATE	CONTENTS		REVD BY	CHKD BY	CHKD BY	APPD BY
▽▽	12.5S								
▽▽▽	3.2S								
▽▽▽▽	0.4S								

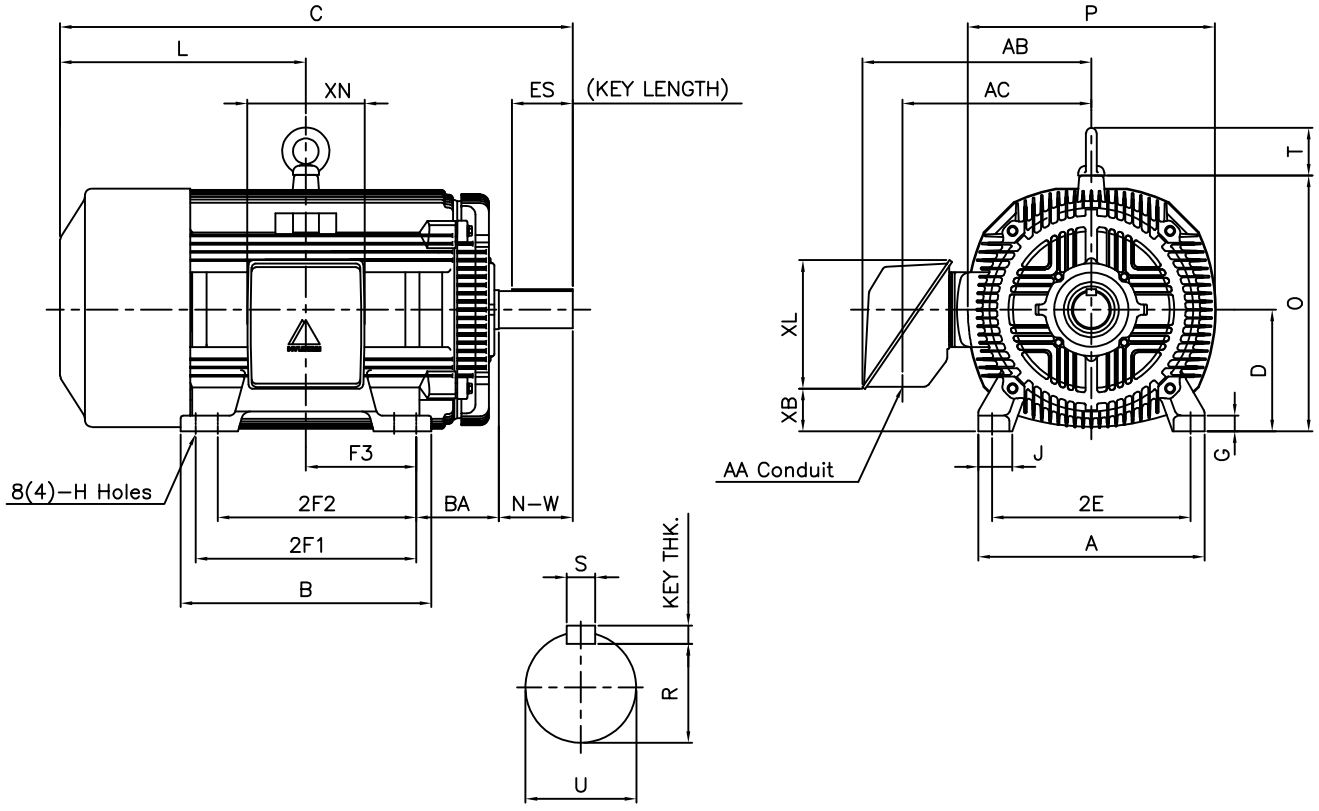

DIMENSIONS

unit : inch

M O U N T I N G									C O N D U I T B O X						APPROX. WGT.(LB)
A	B	2E	2F1	2F2	F3	G	J	H	AA	AB	AC	XB	XL	XN	
20.51	22.72	18.00	20.00	(17.99)	10.000	1.42	3.07	0.81	3.00	21.26	18.03	3.83	11.65	10.63	1900

O V E R A L L							S H A F T					KEY	BEARING	
BA	C	D	L	O	P	T	U	N-W	KEYWAY			THK.	DRIVE END	OPP. DRIVE END
									R	ES	S			
7.50	44.96	11.00	22.71	23.19	22.40	4.33	2.375	4.75	2.021	3.03	0.625	0.625	6314C3	6314C3

NOTE

1. Dimension "D" tolerance : +0.00inch - 0.03inch (143T-365T) ; +0.000inch - 0.06inch (404T-449T)
2. Dimension "U" tolerance : +0.000inch - 0.005inch (143T-215T), +0.000inch - 0.001inch (254T-449T)
3. Dimension "R" tolerance : +0.000inch - 0.015inch

APPD BY	S.K.HAN	UNIT	INCH	SUBJECT	447TS	DWG SIZE	A4 (1:1)
Q.P CHK	I.K.KIM	SCALE	NONE				
CHKD BY	R.G.KIM	PROJEC'N	3rd Angle	TITLE OUTLINE			
DSND BY	B.Y.KIM	DATE	2019.06.05				
				REF. NO	350A1119BA	Sheet No.	of
				DWG NO	LM-T1447B3CL001	Revision No.	0

**Cls. I&II, Div. 2
IEEE 841**

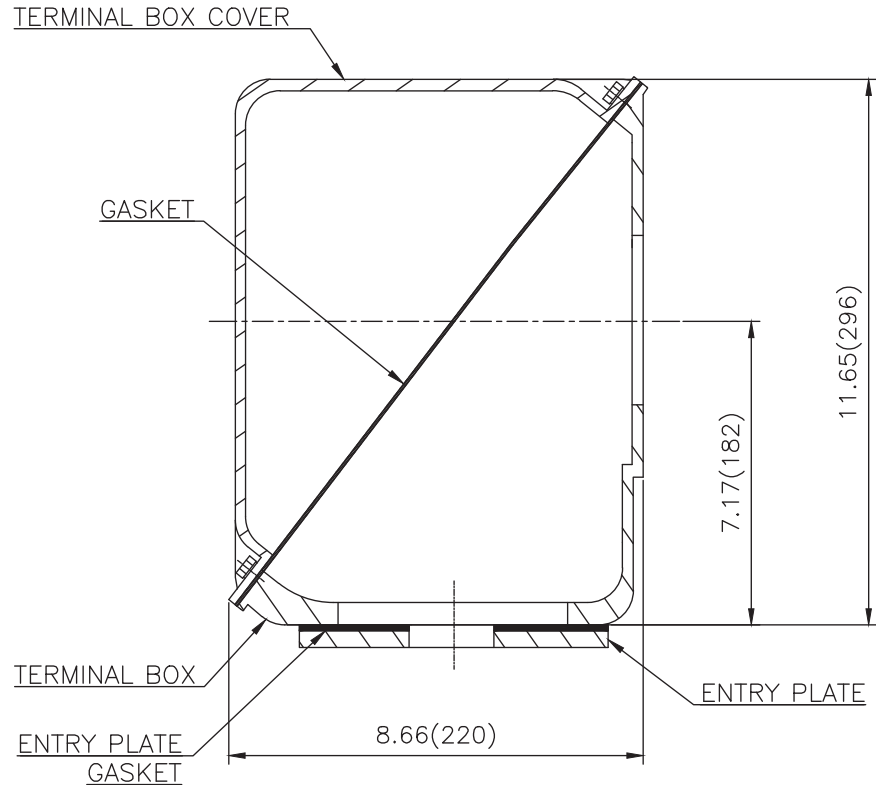
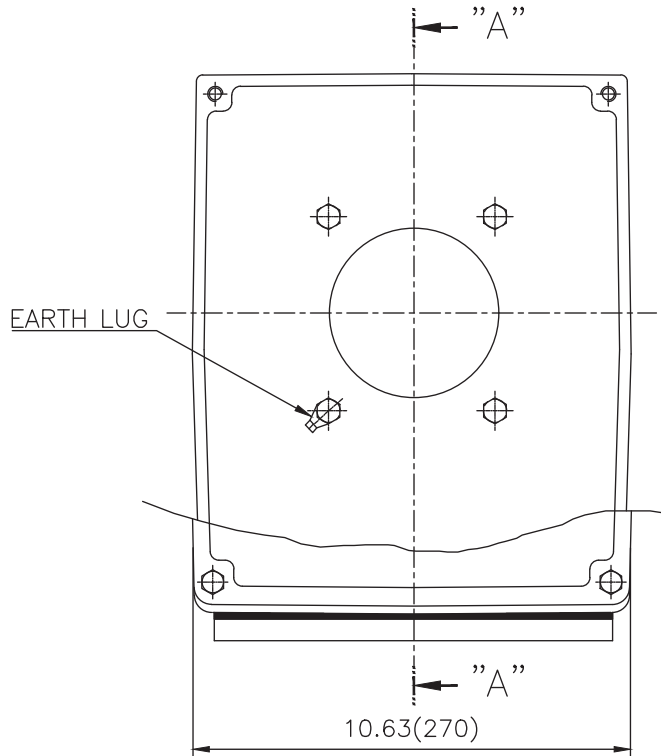

SEC. "A" - "A"

▽	50S
▽▽	12.5S
▽▽▽	3.2S
▽▽▽▽	0.4S

REV	DATE	CONTENTS	REVD BY	CHKD BY	CHKD BY	APPD BY

일반기준공차		일반재판공차	
1-4	±0.1	6-30	±0.5
4-18	±0.2	30-120	±0.8
18-63	±0.3	120-315	±1.2
63-250	±0.5	315-1000	±2.0
250-	±0.8	1000-	±3.0

Q'TY	DESCRIPTION	MATERIAL	DIMENSION	WEIGHT	PART NO.	REMARK	NO.
APPD BY	S.Y.KIM	UNIT	inch(mm)	SUBJECT	FR. 400-440 (CAST IRON)	DWG SIZE	A3 (1:1.2)
CHKD BY		SCALE	1/1.2	TITLE	MAIN TERMINAL BOX ASS'Y		
CHKD BY	R.G.KIM	PROJEC'N	3rd Angle	REF. NO		Sheet No.	of
DSND BY	배승희	DATE	2023-10-19	DWG NO	3M-248451	Revision No.	0

