

Customer :
 Project Name :
 Project No. :
 Revision No. :

SPECIFICATION for INDUCTION MOTOR



0		For Bidding			
No.	DATE	DESCRIPTION	PREPARED BY	CHECKED BY	APPROVED BY



AC INDUCTION MOTOR DATA SHEET

Catalog No.	HES7.5-36-213T	Item No.		Rev. No.	[]
Project Name		Project No.		Quantity	sets

GENERAL SPECIFICATION			PERFORMANCE DATA			
Frame Size	213T		Rated Output	5.5 kW 7.5 HP		
Type	PJP		Number of Poles	2		
Enclosure(Protection)	Totally Enclosed	/ IP55	Rotor Type	Squirrel Cage		
Method of Cooling	IC411(FC)		Starting Method*	D.O.L		
Rated Frequency	60 Hz		Rated Voltage	575 V	460 V	230 V
Number of Phases	3		Current	Full Load	7.26 A	9.07 A
Insulation Class	F			Locked-rotor**	700 %	700 %
Temp. Rise at full load (by resistance method)			Efficiency			
at 1.0 S.F	80 deg. C		50% Load		86.5 %	
Motor Location	<input type="checkbox"/> Indoor <input type="checkbox"/> Outdoor		75% Load		88.5 %	
Altitude	Less than 1,000 meter		100% Load		89.5 %	
Relative Humidity	Less than 80 %		Power Factor(p.u)			
Ambient Temp.	40 deg. C (Max.)		50% Load		0.700	
Duty Type	Continuous (S1)		75% Load		0.800	
Service Factor	1.15		100% Load		0.850	
Mounting	B3		Speed at Full Load	3530 r.p.m		
Bearing	Type	Anti-Friction	Torque			
	DE/N-DE	6208ZZC3 / 6208ZZC3	Full Load		11.0 lb.ft	
	Lubricant	Grease(Polyrex-EM)	Locked-rotor**		160 %	
External Thrust	Not applicable		Breakdown**		260 %	
Coupling Method	<input checked="" type="checkbox"/> Direct <input type="checkbox"/> V-belt		Moment of Inertia (J)			
Shaft Extension	Single		Load(Max.)		8.183 lb.ft2	
Terminal Box	Main	Cast Iron	Motor		0.332 lb.ft2	
	Aux.	No	Sound Pressure Level (No-load & mean value at 1m from motor)			
Location	Refer to Outline Drawing				73 dB(A)	
Application			Vibration		3.8 mm/sec (peak)	
Area classification	Hazardous		Permissible number of consecutive starts		Cold 3 times Hot 2 times	
Type of Ex-Protection	Class I&II, Division 2		Paint	Munsell No.	4.0PB5.4/5.5(VL-451)	
Applicable Standard	NEMA MG1, CSA C390					

ACCESSORIES

SUBMITTAL DRAWING		
Outline Dimension Drawing	Motor Weight(Approx.)	
B3	LM-T2213B3PLV23	150 lb.

SPARE PARTS

REMARK				
1. Premium efficiency according to NEMA MG1 2. Inverter Duty @ 1.0 Service Factor & F Temperature rise -. 10:1 VT (20:1 VT at 50% load) -. 10:1 CT -. CHP up to 1.5 times base speed, NEMA MG1 Part31 3. CSA Certification -. Class I, Division 2, Group A, B, C & D -. Class II, Division 2 Group E, F & G (Group E : up to 320Fr.) 4. Service Factor 1.15 and Temperature rise B are applicable under the condition of sine wave power. 5. Service Factor 1.25 is applicable to motors of 100HP or less with temperature rise F & Non-Hazardous.				
Date	DSND	CHKD	CHKD	APPD
2024-09-10	S.H. Lee	I.K. Kim	R.G. Kim	S.W. Kim

[Note] Others not mentioned in this data sheet shall be in accordance with maker standard.
 Above technical data are only design values and shall be guaranteed with tolerance of applicable standard.
 Inspection and performance test shall be done according to maker standard, if not mentioned.
 * In case of Inverter-Fed Motor, performance data is based on sine wave tests. It may be different from test data of Inverter combined motor.
 ** Data is based on rated voltage & frequency and is expressed as a percentage of full-load value.

1	2	3	4
REV	DATE	CONTENTS	REVD BY CHKD BY CHKD BY APPD BY

3.94

1.57

CROWN TRITON G2 Premium Efficiency
AC 3 Phase Motor

Cat. No. HES7.5-36-213T

7.5HP	2P	230/460V	Amps	18.15/9.07	Type	HLS	Amb.	40°C	
Frame	213T	Duty	CONT	Encl.	TEFC	Model	HLS213SR135	NEMA Nom. Eff.	89.5%
RPM	3530	Hertz	60Hz	S.F.	1.15	INS Class	F HD-F1	3/4 Eff.	88.5%
Bearing	Drive	6208ZCC3	S.F.1.25 (When 100HP or less, Temp Rise F & Non-Hazardous)				NEMA Design	B	
	Opp.	6208ZCC3	S.F.1.00 (10:1 C.T., 20:1 V.T., NEMA-MG1 Part31)				Code	H	
Usable at	50Hz 7.5HP 380V 12.18A 2905rpm S.F.: 1.15 Eff.: 88.5% Code: G								
	50Hz 7.5HP 400/415V 11.78/11.57A 2920/2925rpm S.F.: 1.15 Eff.: 88.5/88.5% Code: G/H								
CSA Certified for	Model	LATER	Type	PJP	Temp. Code	Frame	140-320FR		
	CLASS I, Div. 2, Gr. A, B, C & D CLASS I, Zone 2, Gr. IIA, IIB & IIC		CLASS II, Div. 2, Gr. E, F & G (Gr. E : up to 320FR)		(Sine Wave)	Amb.40°C T3C (160°C) Amb.55°C T3A (180°C)			
No.	-		Date	-		Weight	150 lb		

4M-136021 **MARINE DUTY IEEE45** Made in Vietnam H4 Designed By HYUNDAI, Korea

APPD BY	S.Y.KIM	UNIT	INCH	SUBJECT	CSA Class I, Division2 Severe Duty (HES, 143-215)	DWG SIZE	A4 (1:1)
CHKD BY	I.K.KIM	SCALE	NONE				
CHKD BY	R.G.KIM	PROJEC'N	3rd Angle	NAMEPLATE DRAWING			
DSND BY	S.H.LEE	DATE	2024.06.07				
				REF. NO	4M-136021	Sheet No.	of
				DWG NO	NP-HES7.5-36-213T	Revision No.	0

Type :	PJP
Full Load Torque :	11.0 lb.ft
Load moment of Inertia (J) :	8.183 lb.ft2
Motor moment of Inertia (J) :	0.332 lb.ft2

5.5kW 7.5HP	2 P	60 Hz
Speed at Full Load :		3530 RPM
Rated Voltage	575V	460V 230V
Full Load Current	7.3A	9.1A 18.1A

SPEED VS TORQUE & CURRENT CURVE

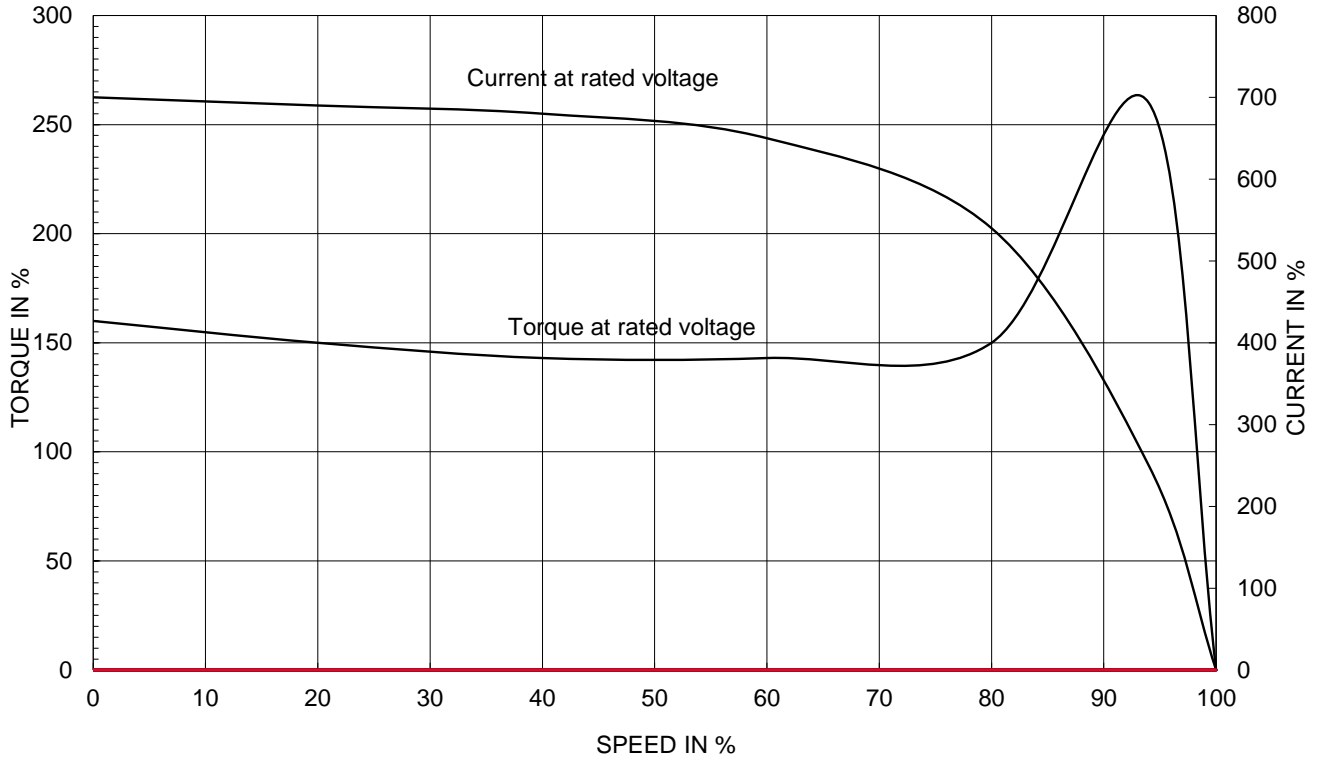

OUTPUT VS EFF., P.F & CURRENT CURVE

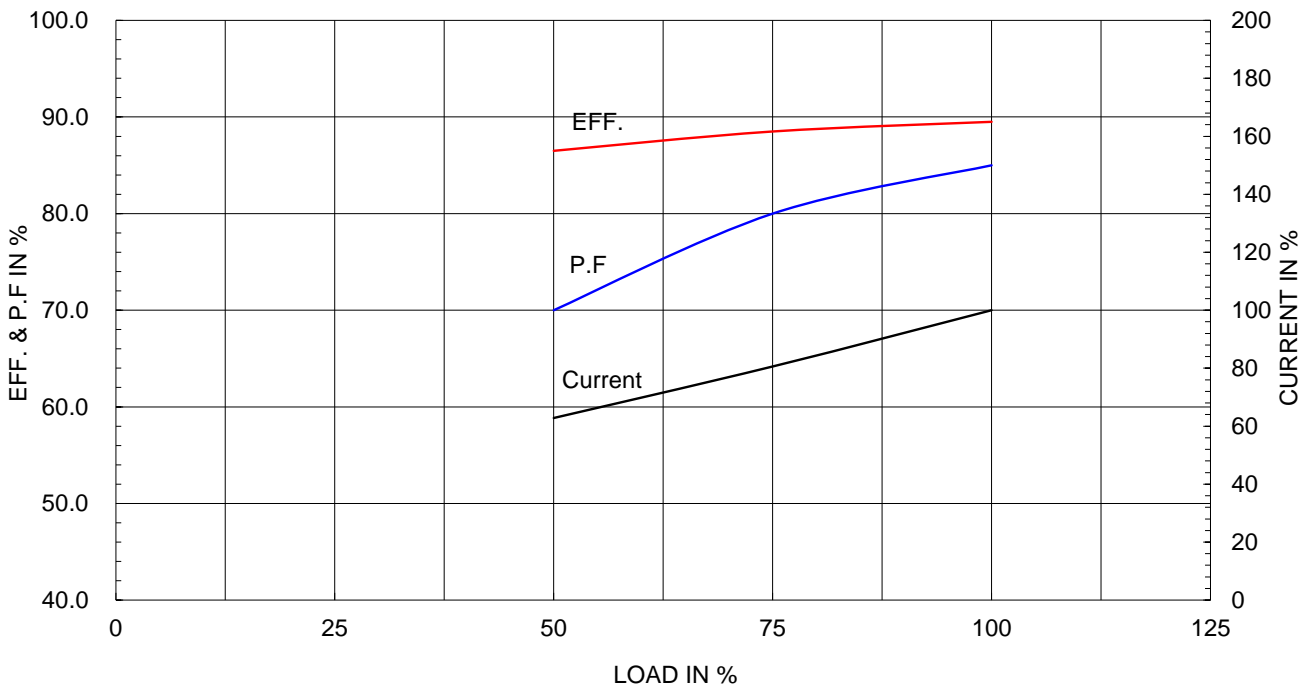

본 도면은 HD현대일렉트릭(주) 재산이며 허가없이 복사할 수 없음 (취급유의)

THIS DRAWING IS PROPRIETARY TO HYUNDAI ELECTRIC. NO PART OF THIS DRAWING MAYBE REPRODUCED WITHOUT THE PERMISSION OF HYUNDAI ELECTRIC.

▽	50S	REV	DATE	CONTENTS	REVD BY	CHKD BY	CHKD BY	APPD BY
▽▽	12.5S							
▽▽▽	3.2S							
▽▽▽▽	0.4S							

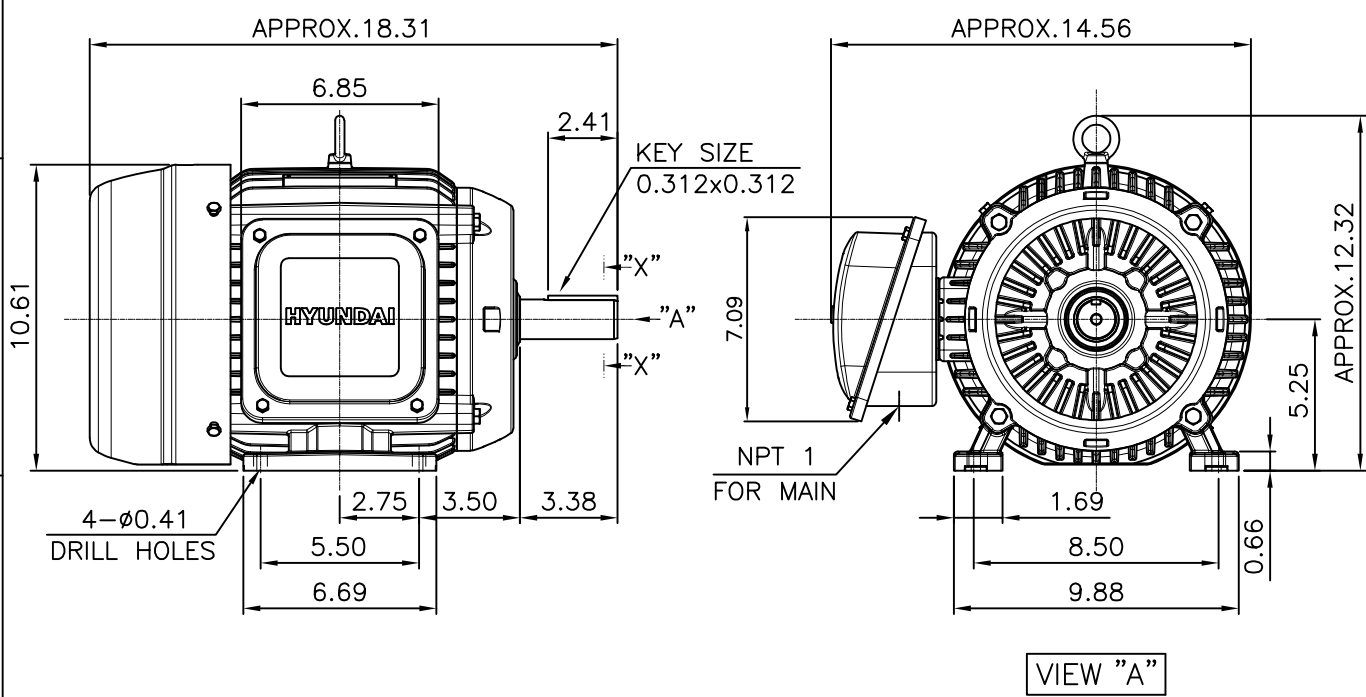

- NOTE**
[TOLERANCE]
- CENTER HEIGHT : +0.00inch - 0.03inch
 - SHAFT DIAMETER : +0.000inch - 0.0005inch
 - KEYWAY DEPTH : +0.000inch - 0.015inch

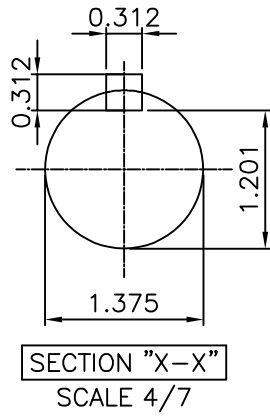

APPD BY	S.Y.KIM	UNIT	inch	SUBJECT	NEMA 213T	DWG SIZE	A4 (1:7)
CHKD BY	R.G.KIM	SCALE	1/7	TITLE	OUTLINE	REF. NO	Sheet No. of
CHKD BY		PROJEC'N	3rd Angle				
DSND BY	주유람	DATE	2021-04-28				
				DWG NO	LM-T2213B3PLV23	Revision No.	0

**Cls. I&II, Div. 2
IEEE 841**



SEC. "A" - "A"

▽	50S
▽▽	12.5S
▽▽▽	3.2S
▽▽▽▽	0.4S

REV	DATE	CONTENTS	REVD BY	CHKD BY	CHKD BY	APPD BY

일반기공公差		일반재관公差	
1-4	±0.1	6-30	±0.5
4-18	±0.2	30-120	±0.8
18-63	±0.3	120-315	±1.2
63-250	±0.5	315-1000	±2.0
250-	±0.8	1000-	±3.0

Q'TY	DESCRIPTION	MATERIAL	DIMENSION	WEIGHT	PART NO.	REMARK	NO.
APPD BY	S.Y.KIM	UNIT	inch(mm)	SUBJECT	FR. 210 (CAST IRON)	DWG SIZE	
CHKD BY		SCALE	1/1.5	TITLE	TERMINAL BOX ASS'Y		
CHKD BY	R.G.KIM	PROJEC'N	3rd Angle	DATE	2023-10-19		
DSND BY	배승희						
REF. NO		Sheet No.	of				
DWG NO	3M-248457	Revision No.	0				

