

Customer :
 Project Name :
 Project No. :
 Revision No. :

SPECIFICATION for INDUCTION MOTOR



0		For Bidding			
No.	DATE	DESCRIPTION	PREPARED BY	CHECKED BY	APPROVED BY

AC INDUCTION MOTOR DATA SHEET

Catalog No.	HES5-12-215TC	Item No.		Rev. No.	[]
Project Name		Project No.		Quantity	sets

GENERAL SPECIFICATION		PERFORMANCE DATA			
Frame Size	215TC	Rated Output	3.7 kW 5 HP		
Type	PJP	Number of Poles	6		
Enclosure(Protection)	Totally Enclosed / IP55	Rotor Type	Squirrel Cage		
Method of Cooling	IC411(FC)	Starting Method*	D.O.L		
Rated Frequency	60 Hz	Rated Voltage	575 V	460 V	230 V
Number of Phases	3	Current	Full Load	6.10 A	7.63 A 15.26 A
Insulation Class	F		Locked-rotor**	680 %	680 % 680 %
Temp. Rise at full load (by resistance method)		Efficiency			
at 1.0 S.F	80 deg. C			50% Load	86.5 %
Motor Location	<input type="checkbox"/> Indoor <input type="checkbox"/> Outdoor			75% Load	88.5 %
Altitude	Less than 1,000 meter			100% Load	89.5 %
Relative Humidity	Less than 80 %	Power Factor(p.u)			
Ambient Temp.	40 deg. C (Max.)			50% Load	0.530
Duty Type	Continuous (S1)			75% Load	0.630
Service Factor	1.15			100% Load	0.680
Mounting	B35	Speed at Full Load	1180 r.p.m		
Bearing	Type	Anti-Friction			
	DE/N-DE	6208ZZC3 / 6208ZZC3			
	Lubricant	Grease(Polyrex-EM)			
External Thrust	Not applicable				
Coupling Method	<input checked="" type="checkbox"/> Direct <input type="checkbox"/> V-belt	Torque			
Shaft Extension	Single			Full Load	22.1 lb.ft
Terminal Box	Main	Cast Iron			
	Aux.	No			
Box	Location	Refer to Outline Drawing			
	Application		Moment of Inertia (J)		
Area classification	Hazardous			Load(Max.)	96.700 lb.ft2
Type of Ex-Protection	Class I&II, Division 2			Motor	1.234 lb.ft2
Applicable Standard	NEMA MG1, CSA C390	Sound Pressure Level (No-load & mean value at 1m from motor)			
				57 dB(A)	
				Vibration	
				3.8 mm/sec (peak)	
		Permissible number of consecutive starts		Cold	3 times
				Hot	2 times
		Paint	Munsell No.	4.0PB5.4/5.5(VL-451)	

ACCESSORIES

SUBMITTAL DRAWING		
Outline Dimension Drawing		Motor Weight(Approx.)
B35	LM-T2215C4PLV23	190 lb.

REMARK
<ol style="list-style-type: none"> 1. Premium efficiency according to NEMA MG1 2. Inverter Duty @ 1.0 Service Factor & F Temperature rise <ul style="list-style-type: none"> - 10:1 VT (20:1 VT at 50% load) - 10:1 CT - CHP up to 1.5 times base speed, NEMA MG1 Part31 3. CSA Certification <ul style="list-style-type: none"> - Class I, Division 2, Group A, B, C & D - Class II, Division 2 Group E, F & G (Group E : up to 320Fr.) 4. Service Factor 1.15 and Temperature rise B are applicable under the condition of sine wave power. 5. Service Factor 1.25 is applicable to motors of 100HP or less with temperature rise F & Non-Hazardous.

SPARE PARTS

Date	DSND	CHKD	CHKD	APPD
2024-09-10	S.H. Lee	I.K. Kim	R.G. Kim	S.W. Kim

[Note] Others not mentioned in this data sheet shall be in accordance with maker standard.
 Above technical data are only design values and shall be guaranteed with tolerance of applicable standard.
 Inspection and performance test shall be done according to maker standard, if not mentioned.

* In case of Inverter-Fed Motor, performance data is based on sine wave tests. It may be different from test data of Inverter combined motor.
 ** Data is based on rated voltage & frequency and is expressed as a percentage of full-load value.

3.94

1.57

CROWN TRITON G2 Premium Efficiency
AC 3 Phase Motor

5HP	6P	230/460V	Amps	15.26/7.63	Type	HLS	Amb.	40°C	
Frame	215TC	Duty	CONT	Encl.	TEFC	Model	HLS215PR335	NEMA Nom. Eff.	89.5%
RPM	1180	Hertz	60Hz	S.F.	1.15	INS Class	F HD-F1	3/4 Eff.	88.5%
Bearing	Drive	6208ZZC3	S.F.1.25 (When 100HP or less, Temp Rise F & Non-Hazardous)				NEMA Design	B Torque	
	Opp.	6208ZZC3	S.F.1.00 (10:1 C.T., 20:1 V.T., NEMA-MG1 Part31)				Code	K	
Usable at	50Hz 5HP 380V 9.68A 970rpm S.F.: 1.15 Eff.: 87.5% Code: H								
	50Hz 5HP 400/415V 10.17/10.79A 975/975rpm S.F.: 1.15 Eff.: 87.5/87.5% Code: K/K								
CSA Certified for	Model	LATER	Type	PJP	Temp. Code	Frame	140-320FR		
	CLASS I, Div. 2, Gr. A, B, C & D		CLASS II, Div. 2, Gr. E, F & G (Gr. E : up to 320FR)			(Sine Wave)	Amb.40°C T3C (160°C)		
No.	-		Date	-		Weight	190 lb		

4M-136021
MARINE DUTY IEEE45
Made in Vietnam H4
Designed By HYUNDAI, Korea

APPD BY	S.Y.KIM	UNIT	INCH	SUBJECT	CSA Class I, Division2 Severe Duty (HES, 143-215)	DWG SIZE
CHKD BY	I.K.KIM	SCALE	NONE	TITLE	NAMEPLATE DRAWING	A4 (1:1)
CHKD BY	R.G.KIM	PROJEC'N	3rd Angle			
DSND BY	S.H.LEE	DATE	2024.06.07			
				REF. NO	4M-136021	Sheet No. of
				DWG NO	NP-HES5-12-215TC	Revision No. 0



PERFORMANCE CURVE

CURVE NO.

PC-HES5-12-215TC

Type :	PJP
Full Load Torque :	22.1 lb.ft
Load moment of Inertia (J) :	96.700 lb.ft2
Motor moment of Inertia (J) :	1.234 lb.ft2

3.7kW 5HP	6 P	60 Hz
Speed at Full Load : 1180 RPM		
Rated Voltage	575V	460V 230V
Full Load Current	6.1A	7.6A 15.3A

SPEED VS TORQUE & CURRENT CURVE

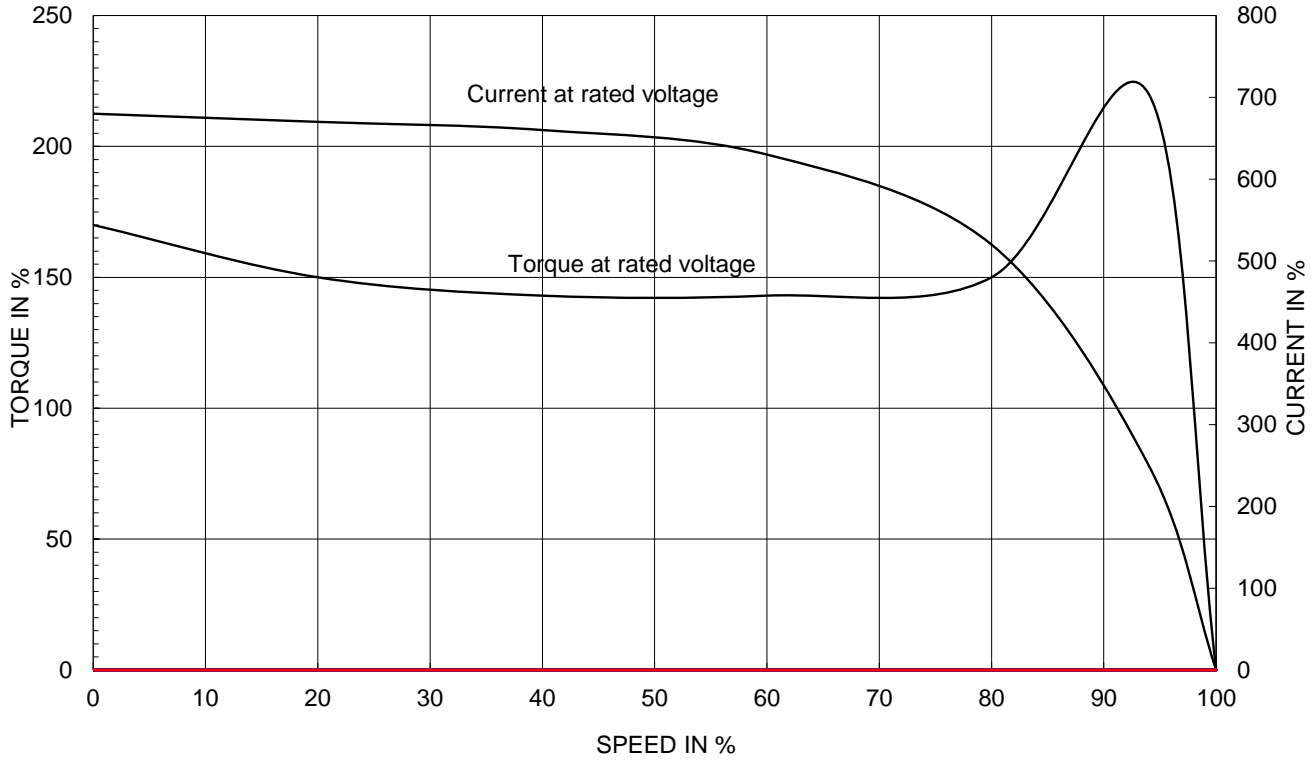

OUTPUT VS EFF., P.F & CURRENT CURVE

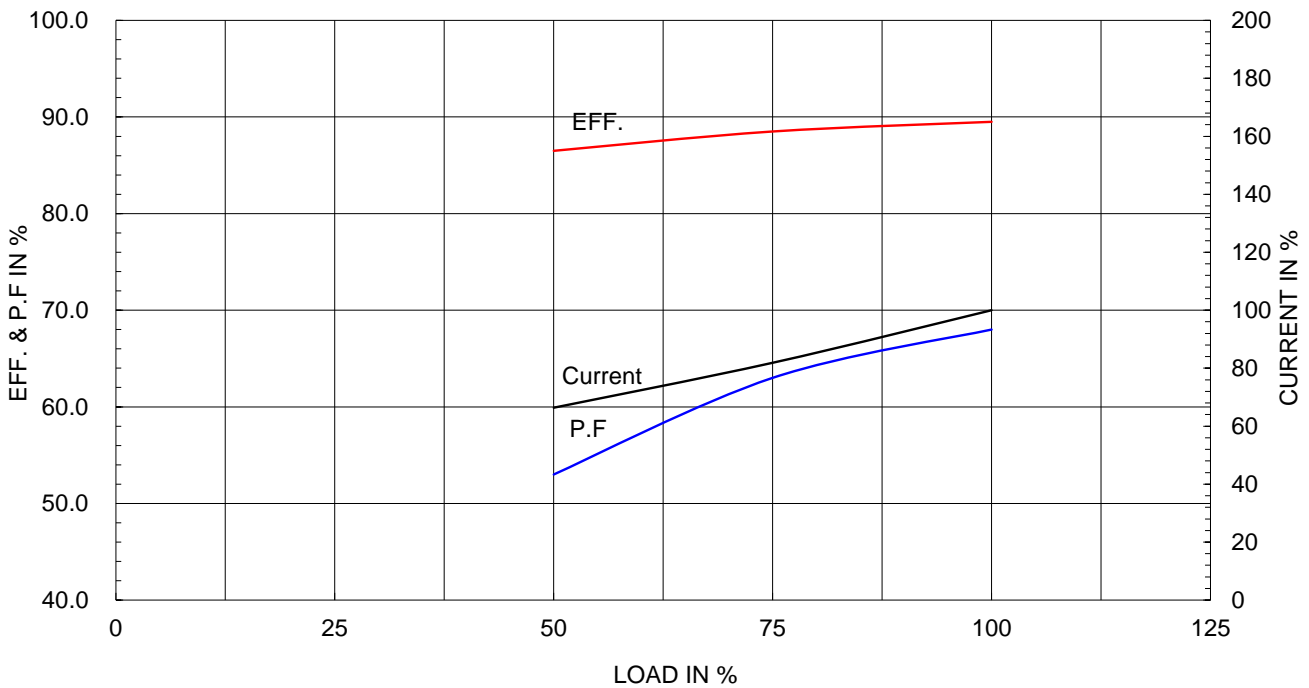

본 도면은 HD현대일렉트릭(주) 재산이며 허가없이 복사할 수 없음 (취급유의)

THIS DRAWING IS PROPRIETARY TO HYUNDAI ELECTRIC. NO PART OF THIS DRAWING MAYBE REPRODUCED WITHOUT THE PERMISSION OF HYUNDAI ELECTRIC.

▽	50S	REV	DATE	CONTENTS	REVD BY	CHKD BY	CHKD BY	APPD BY
▽▽	12.5S							
▽▽▽	3.2S							
▽▽▽▽	0.4S							

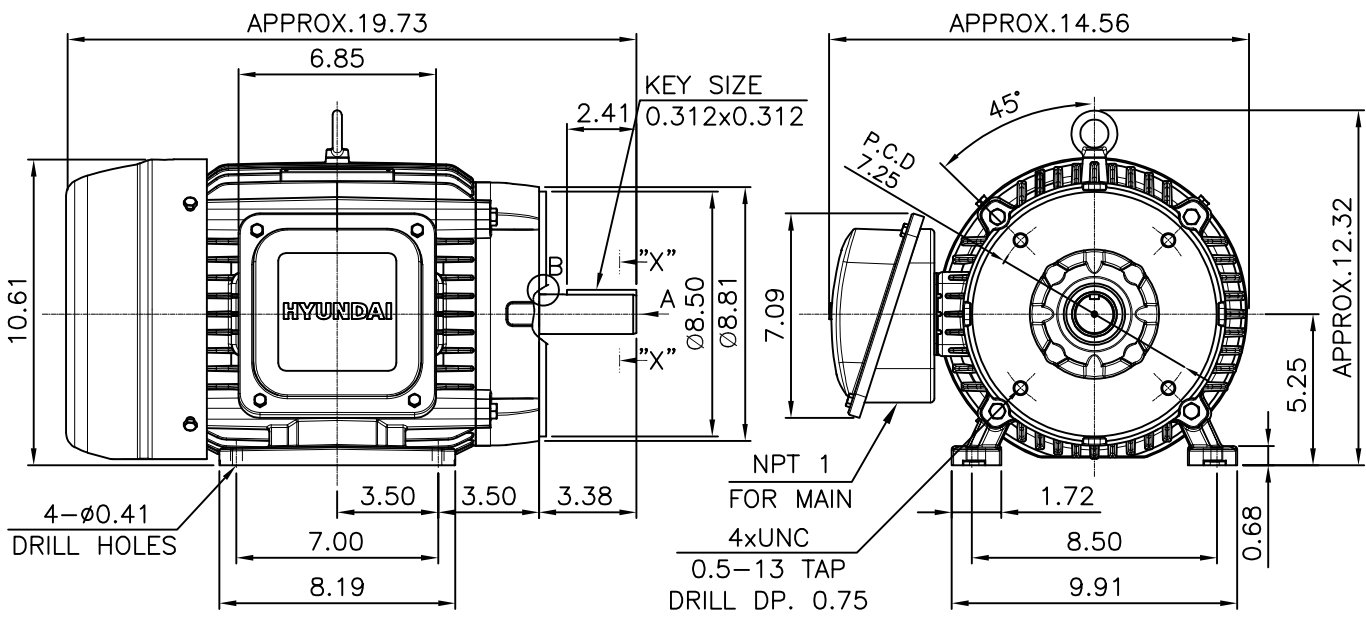

VIEW "A"

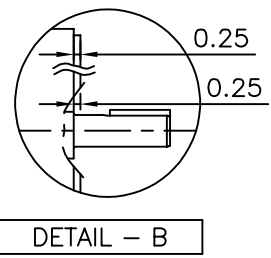

NOTE

[TOLERANCE]

1. CENTER HEIGHT : +0.00inch - 0.03inch
2. SHAFT DIAMETER : +0.000inch - 0.0005inch
3. KEYWAY DEPTH : +0.000inch - 0.015inch

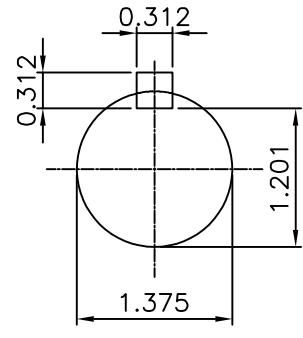

SECTION "X-X"
SCALE 4/7

APPD BY	S.Y.KIM	UNIT	inch	SUBJECT	NEMA 215TC	DWG SIZE	A4 (1:7)
CHKD BY	R.G.KIM	SCALE	1/7	TITLE	OUTLINE	REF. NO	Sheet No. of
CHKD BY		PROJEC'N	3rd Angle				
DSND BY	주유림	DATE	2021-04-29				
				DWG NO	LM-T2215C4PLV23	Revision No.	0

**Cls. I&II, Div. 2
IEEE 841**



▽	50S
▽▽	12.5S
▽▽▽	3.2S
▽▽▽▽	0.4S

REV	DATE	CONTENTS	REVD BY	CHKD BY	CHKD BY	APPD BY

일반기공공차		일반재관공차	
1-4	±0.1	6-30	±0.5
4-18	±0.2	30-120	±0.8
18-63	±0.3	120-315	±1.2
63-250	±0.5	315-1000	±2.0
250-	±0.8	1000-	±3.0

Q'TY	DESCRIPTION	MATERIAL	DIMENSION	WEIGHT	PART NO.	REMARK	NO.
APPD BY	S.Y.KIM	UNIT	inch(mm)	SUBJECT	FR. 210 (CAST IRON)	DWG SIZE	
CHKD BY		SCALE	1/1.5	TITLE	TERMINAL BOX ASS'Y		
CHKD BY	R.G.KIM	PROJEC'N	3rd Angle	DATE	2023-10-19		
DSND BY	배승희						
REF. NO		Sheet No.	of				
DWG NO	3M-248457	Revision No.	0				

