

Customer :
 Project Name :
 Project No. :
 Revision No. :

SPECIFICATION for INDUCTION MOTOR



0		For Bidding			
No.	DATE	DESCRIPTION	PREPARED BY	CHECKED BY	APPROVED BY



AC INDUCTION MOTOR DATA SHEET

Catalog No.	HES30-36-286TSC	Item No.		Rev. No.	[]
Project Name		Project No.		Quantity	sets

GENERAL SPECIFICATION			PERFORMANCE DATA			
Frame Size	286TSC		Rated Output	22 kW		30 HP
Type	PJP		Number of Poles	2		
Enclosure(Protection)	Totally Enclosed	/ IP55	Rotor Type	Squirrel Cage		
Method of Cooling	IC411(FC)		Starting Method*	D.O.L		
Rated Frequency	60 Hz		Rated Voltage	575 V	460 V	230 V
Number of Phases	3		Current	Full Load	27.1 A	33.8 A
Insulation Class	F			Locked-rotor**	685 %	685 %
Temp. Rise at full load (by resistance method)			Efficiency			
at 1.0 S.F	80 deg. C		50% Load		88.7 %	
Motor Location	<input type="checkbox"/> Indoor <input type="checkbox"/> Outdoor		75% Load		90.7 %	
Altitude	Less than 1,000 meter		100% Load		91.7 %	
Relative Humidity	Less than 80 %		Power Factor(p.u)			
Ambient Temp.	40 deg. C (Max.)		50% Load		0.740	
Duty Type	Continuous (S1)		75% Load		0.840	
Service Factor	1.15		100% Load		0.890	
Mounting	B35		Speed at Full Load	3560 r.p.m		
Bearing	Type	Anti-Friction	Torque			
	DE/N-DE	6310ZC3 / 6310ZC3	Full Load		43.5 lb.ft	
	Lubricant	Grease(Polyrex-EM)	Locked-rotor**		160 %	
External Thrust	Not applicable		Breakdown**		230 %	
Coupling Method	<input checked="" type="checkbox"/> Direct <input type="checkbox"/> V-belt		Moment of Inertia (J)			
Shaft Extension	Single		Load(Max.)		28.400 lb.ft2	
Terminal Box	Main	Cast Iron	Motor		2.089 lb.ft2	
	Aux.	No	Sound Pressure Level (No-load & mean value at 1m from motor)			
Location	Refer to Outline Drawing				80 dB(A)	
Application			Vibration		3.8 mm/sec (peak)	
Area classification	Hazardous		Permissible number of consecutive starts		Cold 3 times Hot 2 times	
Type of Ex-Protection	Class I&II, Division 2		Paint		Munsell No. 4.0PB5.4/5.5(VL-451)	
Applicable Standard	NEMA MG1, CSA C390					

ACCESSORIES

SUBMITTAL DRAWING		
Outline Dimension Drawing	Motor Weight(Approx.)	
B35	LM-T2286C4CLV23	430 lb.

SPARE PARTS

REMARK				
1. Premium efficiency according to NEMA MG1 2. Inverter Duty @ 1.0 Service Factor & F Temperature rise -. 10:1 VT (20:1 VT at 50% load) -. 10:1 CT -. CHP up to 1.5 times base speed, NEMA MG1 Part31 3. CSA Certification -. Class I, Division 2, Group A, B, C & D -. Class II, Division 2 Group E, F & G (Group E : up to 320Fr.) 4. Service Factor 1.15 and Temperature rise B are applicable under the condition of sine wave power. 5. Service Factor 1.25 is applicable to motors of 100HP or less with temperature rise F & Non-Hazardous.				
Date	DSND	CHKD	CHKD	APPD
2024-09-10	S.H. Lee	I.K. Kim	R.G. Kim	S.W. Kim

[Note] Others not mentioned in this data sheet shall be in accordance with maker standard.
 Above technical data are only design values and shall be guaranteed with tolerance of applicable standard.
 Inspection and performance test shall be done according to maker standard, if not mentioned.
 * In case of Inverter-Fed Motor, performance data is based on sine wave tests. It may be different from test data of Inverter combined motor.
 ** Data is based on rated voltage & frequency and is expressed as a percentage of full-load value.

1	2	3	4
REV	DATE	CONTENTS	REVD BY CHKD BY CHKD BY APPD BY

4.72

CROWN TRITON G2
Premium Efficiency AC 3 Phase Motor



30HP	2P	230/460V	Cat. No.	HES30-36-286TSC						
Model	HLS286PR13		INS. Class	F	HD-F1	Amps	67.7/33.8			
Type	HLS	Duty	CONT	Code	G	Amb.	40°C	Hertz	60Hz	
Frame	286TSC	Encl.	TEFC	S.F.	1.15	RPM	3560	NEMA Nom. Eff.	91.7%	
Bearing	Drive	6310ZC3		S.F.1.25 (When 100HP or less, Temp Rise F & Non-Hazardous)		3/4 Eff.	90.7%			
	Opp.	6310ZC3		S.F.1.00 (10:1 C.T., 20:1 V.T., NEMA-MG1 Part31)		NEMA Design	B			
Usable at	50Hz 30HP 380V 45.73A 2950rpm S.F.: 1 Eff.: 91% Code: E									
	50Hz 30HP 400/415V 43.79/42.65A 2955/2960rpm S.F.: 1 Eff.: 91/91% Code: F/G									
CSA Certified for	Model	LATER		Type	PJP	Temp. Code	Frame	140~320FR	360~400FR	440FR
	CLASS I, Div. 2, Gr. A, B, C & D		CLASS II, Div. 2 Gr. E, F & G (Gr. E: Up to 320FR)		(sine wave)	Amb. 40°C	T3C (160°C)	T3B (165°C)	T3A (180°C)	
CLASS I, Zone 2, Gr. IIA, IIB, & IIC					Amb. 55°C	T3A (180°C)	T3A (180°C)	T3 (200°C)		
No.	-		Date	-		Weight	430 lb			

4M-136024
MARINE DUTY IEEE45

Made in Vietnam H4
Designed By HYUNDAI, Korea



2.36

APPD BY	S.Y.KIM	UNIT	INCH	SUBJECT	CSA Class I, Division2 Severe Duty (HES, 254-326)	DWG SIZE	A4 (1:1)
CHKD BY	I.K.KIM	SCALE	NONE				
CHKD BY	R.G.KIM	PROJEC'N	3rd Angle	TITLE NAMEPLATE DRAWING			
DSND BY	S.H.LEE	DATE	2024.06.07				
				REF. NO	4M-136024	Sheet No.	of
				DWG NO	NP-HES30-36-286TSC	Revision No.	0



PERFORMANCE CURVE

CURVE NO.

PC-HES30-36-286TSC

Type :	PJP
Full Load Torque :	43.5 lb.ft
Load moment of Inertia (J) :	28.400 lb.ft2
Motor moment of Inertia (J) :	2.089 lb.ft2

22kW 30HP	2 P	60 Hz
Speed at Full Load :		3560 RPM
Rated Voltage	575V	460V 230V
Full Load Current	27.1A	33.8A 67.7A

SPEED VS TORQUE & CURRENT CURVE

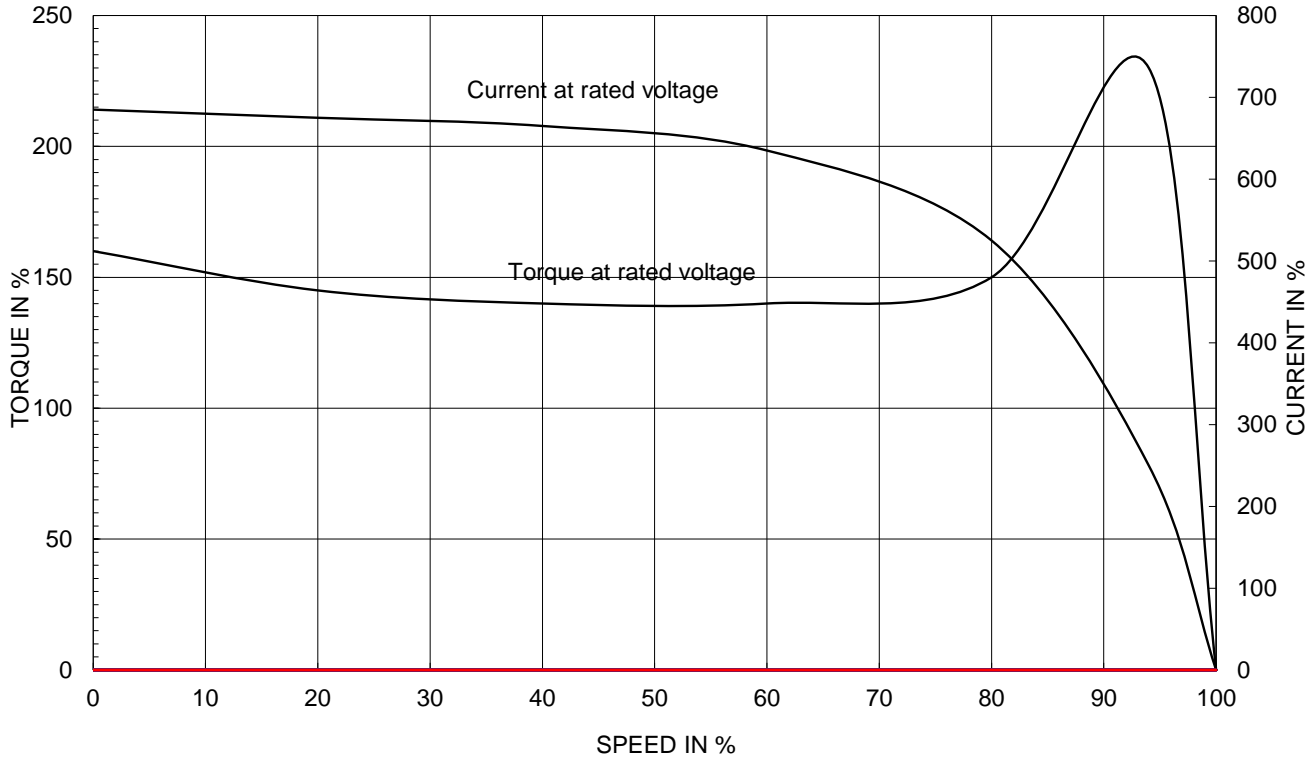

OUTPUT VS EFF., P.F & CURRENT CURVE

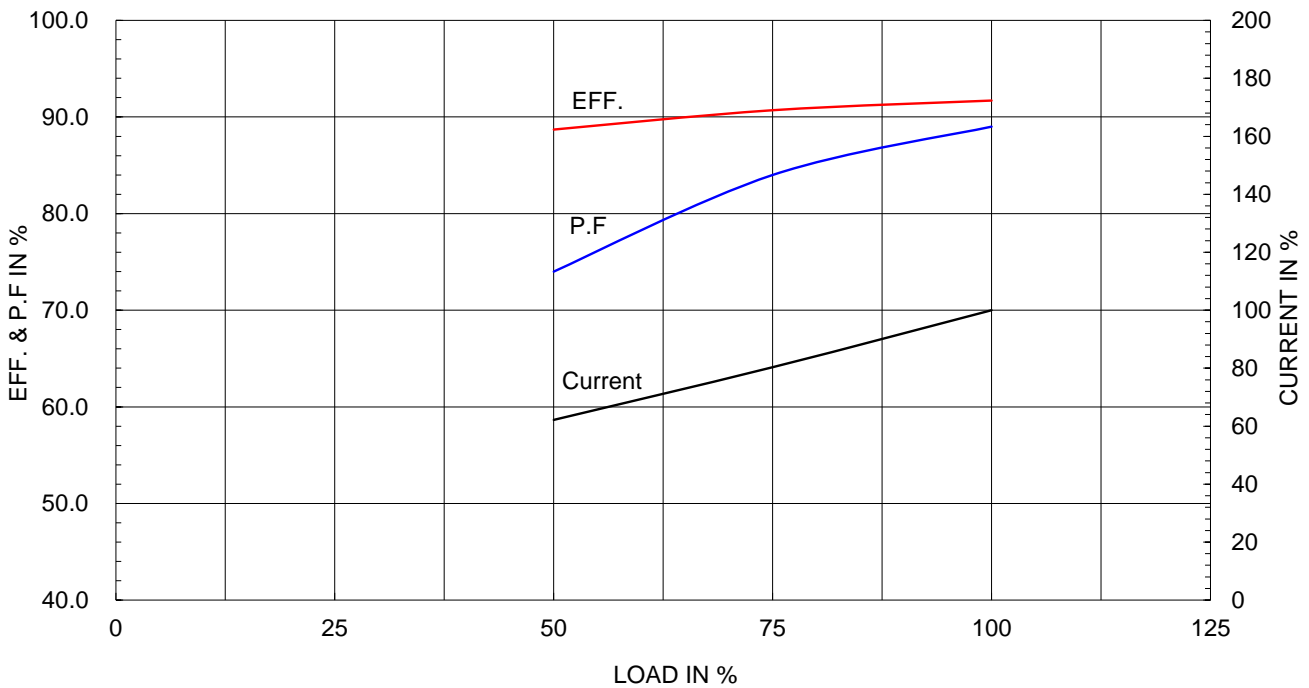

본 도면은 HD현대일렉트릭(주) 재산이며 허가없이 복사할 수 없음 (취급유의)

THIS DRAWING IS PROPRIETARY TO HYUNDAI ELECTRIC. NO PART OF THIS DRAWING MAYBE REPRODUCED WITHOUT THE PERMISSION OF HYUNDAI ELECTRIC.

▽	50S	REV	DATE	CONTENTS	REVD BY	CHKD BY	CHKD BY	APPD BY
▽▽	12.5S							
▽▽▽	3.2S							
▽▽▽▽	0.4S							

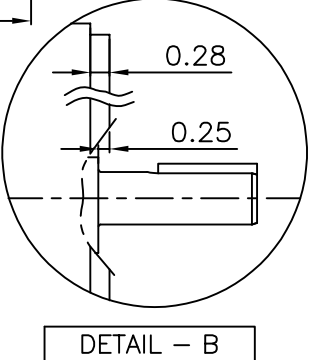
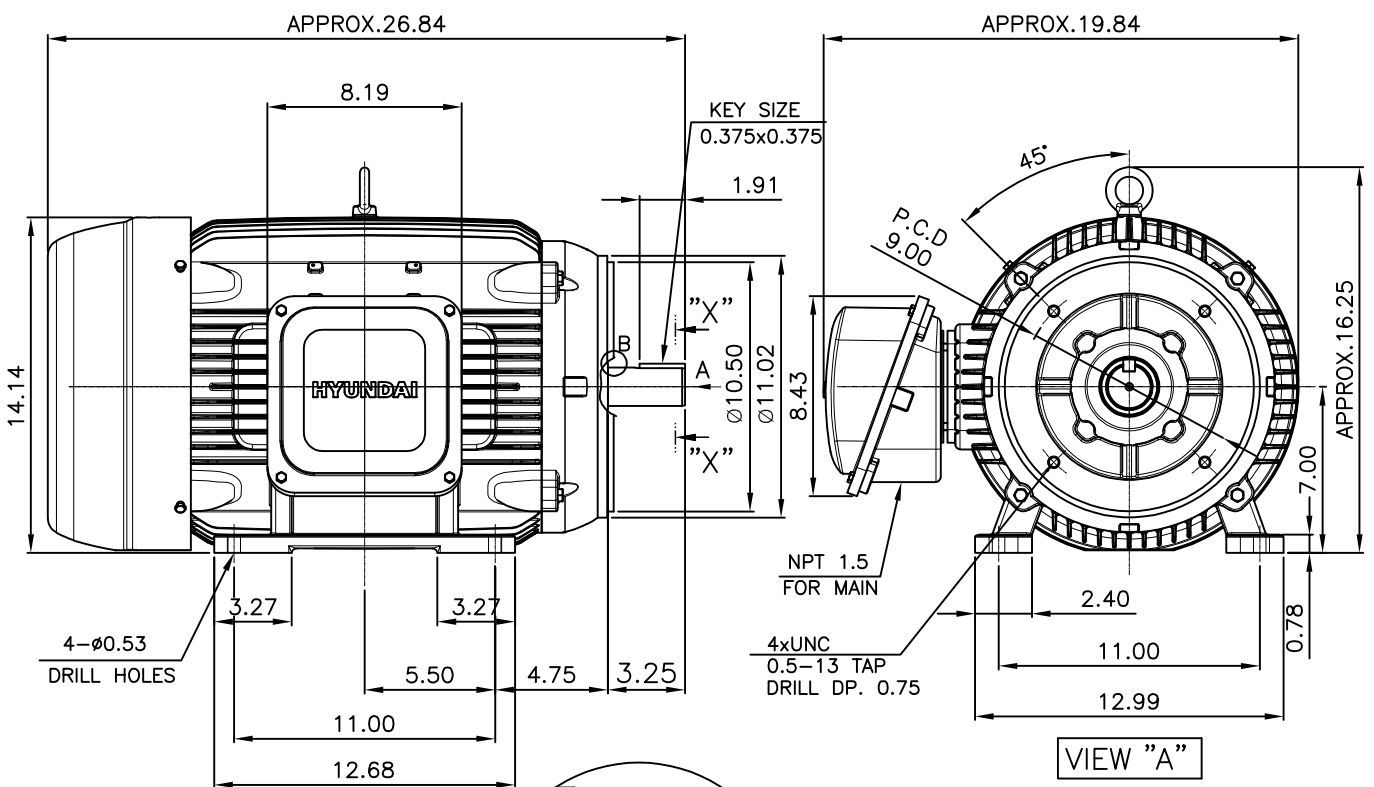

NOTE

[TOLERANCE]

1. CENTER HEIGHT : +0.00inch - 0.03inch
2. SHAFT DIAMETER : +0.000inch - 0.001inch
3. KEYWAY DEPTH : +0.000inch - 0.015inch

SECTION "X-X"
SCALE 4/8.5

APPD BY	S.Y.KIM	UNIT	inch	SUBJECT	NEMA 286TSC	DWG SIZE	A4 (18.5)
CHKD BY	R.G.KIM	SCALE	1/8.5	TITLE	OUTLINE	REF. NO	Sheet No. of
CHKD BY		PROJEC'N	3rd Angle				
DSND BY	주유람	DATE	2021-04-29				
				DWG NO	LM-T2286C4CLV23	Revision No.	0



Cls. I&II, Div. 2 IEEE 841



SEC. "A"-"A"

▽	50S
▽▽	12.5S
▽▽▽	3.2S
▽▽▽▽	0.4S

Q'TY	DESCRIPTION	MATERIAL	DIMENSION	WEIGHT	PART NO.	REMARK	NO.
APPD BY	S.Y.KIM	UNIT	inch(mm)	SUBJECT	FR. 250-280 (CAST IRON)	DWG SIZE	
CHKD BY		SCALE	1/2	TITLE		A3 (1:2)	
CHKD BY	R.G.KIM	PROJEC'N	3rd Angle	TERMINAL BOX ASS'Y			
DSND BY	배승희	DATE	2023-10-19	REF. NO		Sheet No.	of
				DWG NO	3M-248458	Revision No.	0

일반가공공차		일반제관공차	
1-4	±0.1	6-30	±0.5
4-18	±0.2	30-120	±0.8
18-63	±0.3	120-315	±1.2
63-250	±0.5	315-1000	±2.0
250-	±0.8	1000-	±3.0



REV	DATE	CONTENTS	REVD BY	CHKD BY	CHKD BY	APPD BY
1						