

Customer :  
 Project Name :  
 Project No. :  
 Revision No. :

# SPECIFICATION for INDUCTION MOTOR



0		For Bidding			
No.	DATE	DESCRIPTION	PREPARED BY	CHECKED BY	APPROVED BY



# AC INDUCTION MOTOR DATA SHEET

Catalog No.	HES20-36-256TCRD	Item No.		Rev. No.	[     ]
Project Name		Project No.		Quantity	sets

GENERAL SPECIFICATION			PERFORMANCE DATA			
Frame Size	256TC		Rated Output	15 kW		20 HP
Type	PJP		Number of Poles	2		
Enclosure(Protection)	Totally Enclosed	/ IP55	Rotor Type	Squirrel Cage		
Method of Cooling	IC411(FC)		Starting Method*	D.O.L		
Rated Frequency	60 Hz		Rated Voltage	575 V	460 V	230 V
Number of Phases	3		Current	Full Load	18.6 A	23.2 A
Insulation Class	F			Locked-rotor**	740 %	740 %
Temp. Rise at full load (by resistance method)			Efficiency			
at 1.0 S.F	80 deg. C		50% Load		88.0 %	
Motor Location	<input type="checkbox"/> Indoor <input type="checkbox"/> Outdoor		75% Load		90.0 %	
Altitude	Less than 1,000 meter		100% Load		91.0 %	
Relative Humidity	Less than 80 %		Power Factor(p.u)			
Ambient Temp.	40 deg. C (Max.)		50% Load		0.740	
Duty Type	Continuous ( S1 )		75% Load		0.840	
Service Factor	1.15		100% Load		0.890	
Mounting	B5		Speed at Full Load	3550 r.p.m		
Bearing	Type	Anti-Friction	Torque			
	DE/N-DE	6309ZC3 / 6309ZC3	Full Load		29.8 lb.ft	
	Lubricant	Grease(Polyrex-EM)	Locked-rotor**		150 %	
External Thrust	Not applicable		Breakdown**		250 %	
Coupling Method	<input checked="" type="checkbox"/> Direct <input type="checkbox"/> V-belt		Moment of Inertia (J)			
Shaft Extension	Single		Load(Max.)		21.594 lb.ft2	
Terminal Box	Main	Cast Iron	Motor		1.163 lb.ft2	
	Aux.	No	Sound Pressure Level (No-load & mean value at 1m from motor)			
	Location	Refer to Outline Drawing	77 dB(A)			
Application			Vibration			
Area classification	Hazardous		3.8 mm/sec (peak)			
Type of Ex-Protection	Class I&II, Division 2		Permissible number of consecutive starts		Cold 3 times	
Applicable Standard	NEMA MG1, CSA C390		Hot		2 times	
	Paint	Munsell No.	4.0PB5.4/5.5(VL-451)			

ACCESSORIES

SUBMITTAL DRAWING		
Outline Dimension Drawing	Motor Weight(Approx.)	
B5	LM-T2256C5PLV23	300 lb.

SPARE PARTS

REMARK				
1. Premium efficiency according to NEMA MG1 2. Inverter Duty @ 1.0 Service Factor & F Temperature rise -. 10:1 VT (20:1 VT at 50% load) -. 10:1 CT -. CHP up to 1.5 times base speed, NEMA MG1 Part31 3. CSA Certification -. Class I, Division 2, Group A, B, C & D -. Class II, Division 2 Group E, F & G (Group E : up to 320Fr.) 4. Service Factor 1.15 and Temperature rise B are applicable under the condition of sine wave power. 5. Service Factor 1.25 is applicable to motors of 100HP or less with temperature rise F & Non-Hazardous.				
Date	DSND	CHKD	CHKD	APPD
2024-09-10	S.H. Lee	I.K. Kim	R.G. Kim	S.W. Kim

[Note] Others not mentioned in this data sheet shall be in accordance with maker standard.  
 Above technical data are only design values and shall be guaranteed with tolerance of applicable standard.  
 Inspection and performance test shall be done according to maker standard, if not mentioned.  
 \* In case of Inverter-Fed Motor, performance data is based on sine wave tests. It may be different from test data of Inverter combined motor.  
 \*\* Data is based on rated voltage & frequency and is expressed as a percentage of full-load value.

1	2	3	4
REV	DATE	CONTENTS	REVD BY CHKD BY CHKD BY APPD BY

4.72



**CROWN TRITON G2**  
Premium Efficiency AC 3 Phase Motor

20HP	2P	230/460V	Cat. No.	HES20-36-256TCRD						
Model	HLS256PR13		INS. Class	F	HD-F1	Amps	46.5/23.2			
Type	HLS	Duty	CONT	Code	H	Amb.	40°C	Hertz	60Hz	
Frame	256TC	Encl.	TEFC	S.F.	1.15	RPM	3550	NEMA Nom. Eff.	91%	
Bearing	Drive	6309ZC3		S.F.1.25 (When 100HP or less, Temp Rise F & Non-Hazardous)		3/4 Eff.	90%			
	Opp.	6309ZC3		S.F.1.00 (10:1 C.T., 20:1 V.T., NEMA-MG1 Part31)		NEMA Design	B Torque			
Usable at	50Hz 20HP 380V 31.17A 2935rpm S.F.: 1 Eff.: 90.2% Code: G									
	50Hz 20HP 400/415V 29.89/29.11A 2945/2950rpm S.F.: 1 Eff.: 90.2/90.2% Code: H/H									
CSA Certified for	Model	LATER		Type	PJP	Temp. Code	Frame	140~320FR	360~400FR	440FR
	CLASS I, Div. 2, Gr. A, B, C & D		CLASS II, Div. 2 Gr. E, F & G (Gr. E: Up to 320FR)			(sine wave)	Amb. 40°C	T3C (160°C)	T3B (165°C)	T3A (180°C)
CLASS I, Zone 2, Gr. IIA, IIB, & IIC						Amb. 55°C	T3A (180°C)	T3A (180°C)	T3 (200°C)	
No.	-		Date	-		Weight	300 lb			

4M-136024  
**MARINE DUTY IEEEE45**

Made in Vietnam H4  
Designed By HYUNDAI, Korea



2.36

APPD BY	S.Y.KIM	UNIT	INCH	SUBJECT	CSA Class I, Division2 Severe Duty (HES, 254-326)	DWG SIZE
CHKD BY	I.K.KIM	SCALE	NONE			A4 ( 1:1 )
CHKD BY	R.G.KIM	PROJEC'N	3rd Angle	NAMEPLATE DRAWING		
DSND BY	S.H.LEE	DATE	2024.06.07			
				REF. NO	4M-136024	Sheet No. of
				DWG NO	NP-HES20-36-256TCRD	Revision No. 0



# PERFORMANCE CURVE

CURVE NO.  
PC-HES20-36-256TCRD

Type :	PJP
Full Load Torque :	29.8 lb.ft
Load moment of Inertia (J) :	21.594 lb.ft2
Motor moment of Inertia (J) :	1.163 lb.ft2

15kW	20HP	2 P	60 Hz
Speed at Full Load :			3550 RPM
Rated Voltage	575V	460V	230V
Full Load Current	18.6A	23.2A	46.5A

SPEED VS TORQUE & CURRENT CURVE

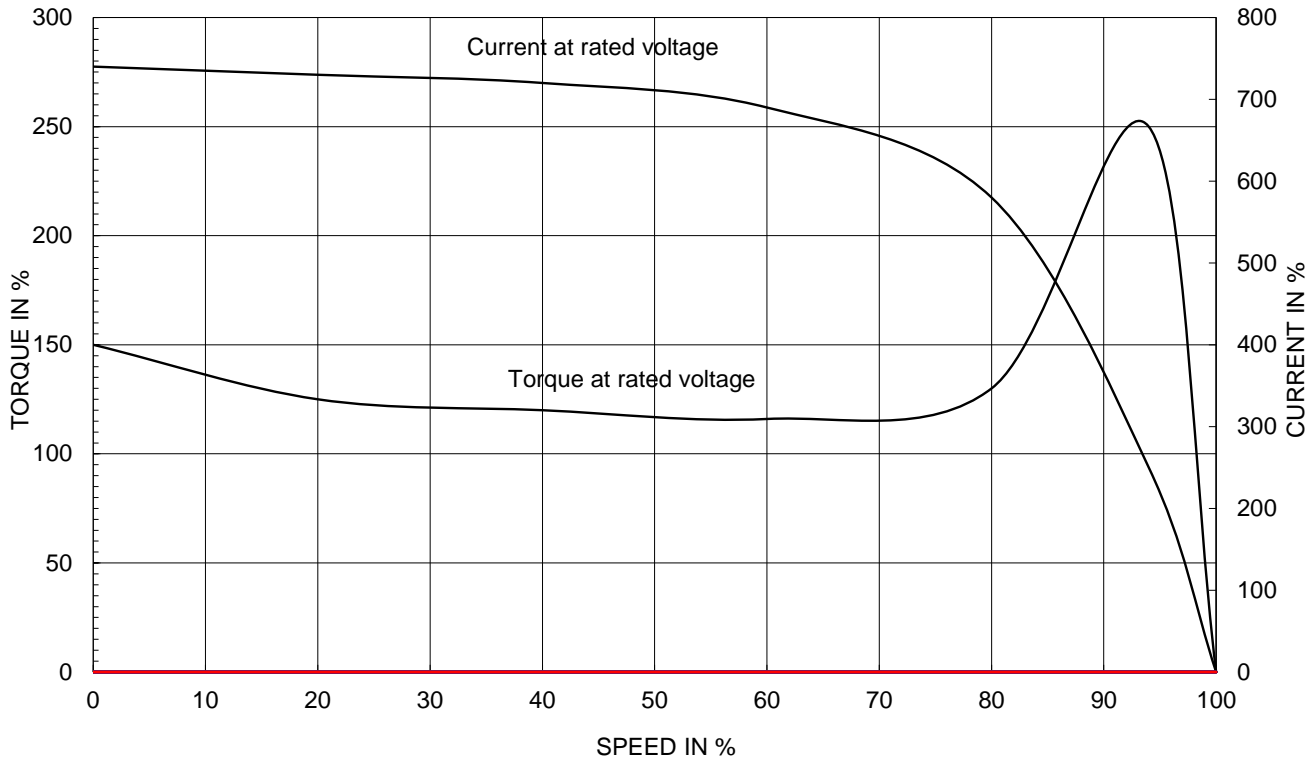

OUTPUT VS EFF., P.F & CURRENT CURVE

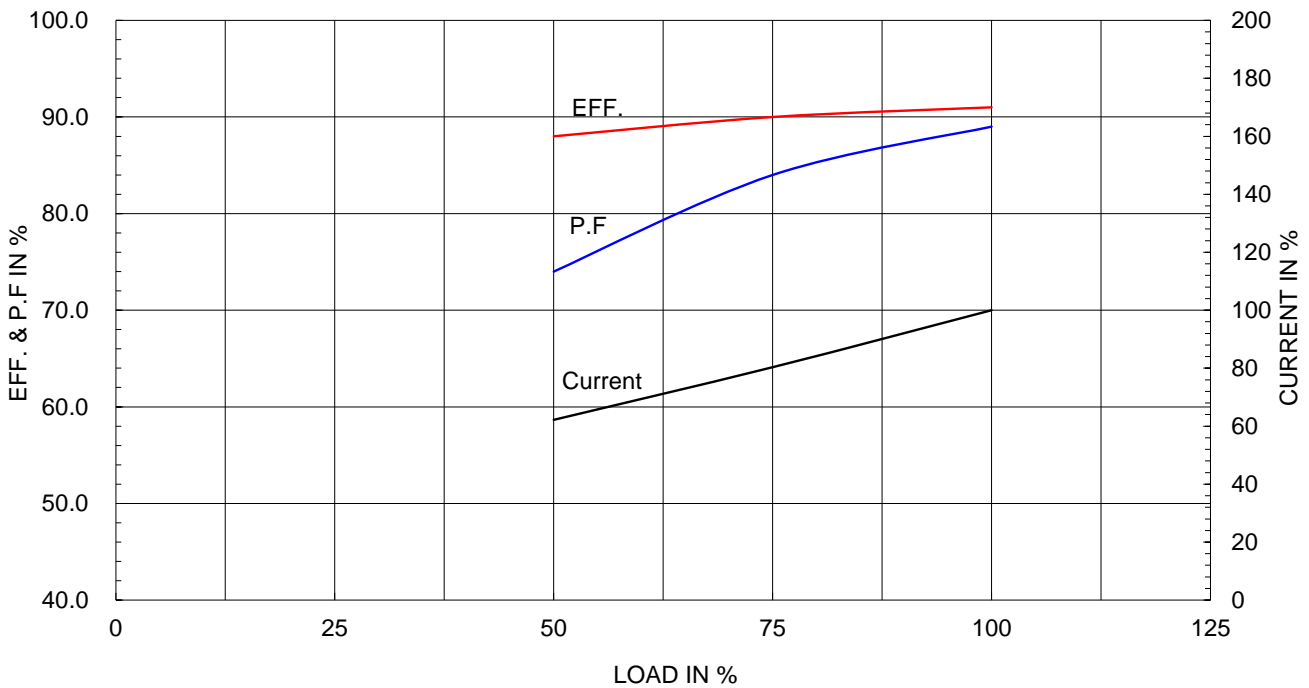

본 도면은 HD현대일렉트릭(주) 재산이며 허가없이 복사할 수 없음 (취급유의)

THIS DRAWING IS PROPRIETARY TO HYUNDAI ELECTRIC. NO PART OF THIS DRAWING MAYBE REPRODUCED WITHOUT THE PERMISSION OF HYUNDAI ELECTRIC.

▽	50S	REV	DATE	CONTENTS	REVD BY	CHKD BY	CHKD BY	APPD BY
▽▽	12.5S							
▽▽▽	3.2S							
▽▽▽▽	0.4S							

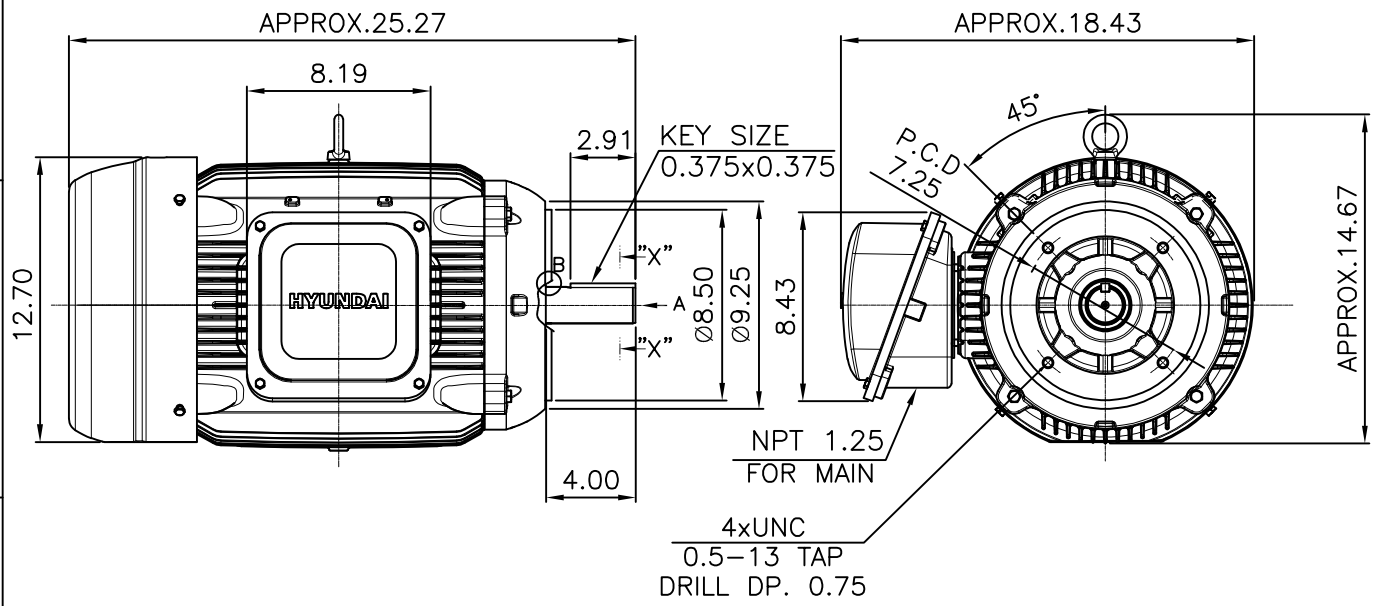

VIEW "A"

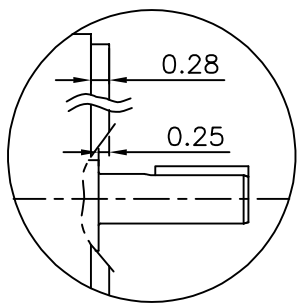

DETAIL - B

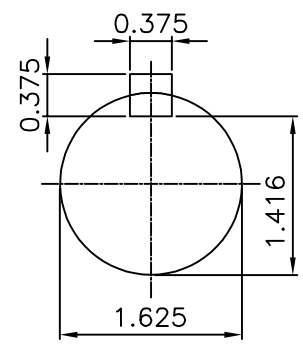

SECTION "X-X"  
SCALE 5/9

**NOTE**

[TOLERANCE]

1. CENTER HEIGHT : +0.00inch - 0.03inch
2. SHAFT DIAMETER : +0.000inch - 0.001inch
3. KEYWAY DEPTH : +0.000inch - 0.015inch

APPD BY	S.Y.KIM	UNIT	inch	SUBJECT	NEMA 256TC	DWG SIZE	A4 ( 1:9 )
CHKD BY	R.G.KIM	SCALE	1/9	TITLE	OUTLINE	REF. NO	Sheet No. of
CHKD BY		PROJEC'N	3rd Angle				
DSND BY	주유람	DATE	2021-04-28				
				DWG NO	LM-T2256C5PLV23	Revision No.	0



# Cls. I&II, Div. 2 IEEE 841



▽	50S
▽▽	12.5S
▽▽▽	3.2S
▽▽▽▽	0.4S

REV	DATE	CONTENTS	REVD BY	CHKD BY	CHKD BY	APPD BY

일반가공공차		일반제관공차	
1-4	±0.1	6-30	±0.5
4-18	±0.2	30-120	±0.8
18-63	±0.3	120-315	±1.2
63-250	±0.5	315-1000	±2.0
250-	±0.8	1000-	±3.0

Q'TY	DESCRIPTION	MATERIAL	DIMENSION	WEIGHT	PART NO.	REMARK	NO.
APPD BY	S.Y.KIM	UNIT	inch(mm)	SUBJECT	FR. 250-280 (CAST IRON)	DWG SIZE	
CHKD BY		SCALE	1/2	TITLE		A3 ( 1:2 )	
CHKD BY	R.G.KIM	PROJEC'N	3rd Angle	TERMINAL BOX ASS'Y			
DSND BY	배승희	DATE	2023-10-19	REF. NO		Sheet No.	of
				DWG NO	3M-248458	Revision No.	0