

Customer :  
 Project Name :  
 Project No. :  
 Revision No. :

# SPECIFICATION for INDUCTION MOTOR



0		For Bidding			
No.	DATE	DESCRIPTION	PREPARED BY	CHECKED BY	APPROVED BY



# AC INDUCTION MOTOR DATA SHEET

Catalog No.	HES20-18-256TC	Item No.		Rev. No.	[     ]
Project Name		Project No.		Quantity	sets

GENERAL SPECIFICATION			PERFORMANCE DATA				
Frame Size	256TC		Rated Output	15 kW      20 HP			
Type	PJP		Number of Poles	4			
Enclosure(Protection)	Totally Enclosed / IP55		Rotor Type	Squirrel Cage			
Method of Cooling	IC411(FC)		Starting Method*	D.O.L			
Rated Frequency	60 Hz		Rated Voltage	575 V	460 V	230 V	
Number of Phases	3		Current	Full Load	19.9 A	24.8 A	49.7 A
Insulation Class	F			Locked-rotor**	800 %	800 %	800 %
Temp. Rise at full load (by resistance method)			Efficiency				
at 1.0 S.F			80 deg. C				
Motor Location	<input type="checkbox"/> Indoor <input type="checkbox"/> Outdoor		50% Load		90.0 %		
Altitude	Less than 1,000 meter		75% Load		92.0 %		
Relative Humidity	Less than 80 %		100% Load		93.0 %		
Ambient Temp.	40 deg. C (Max.)		Power Factor(p.u)				
Duty Type	Continuous ( S1 )		50% Load		0.665		
Service Factor	1.15		75% Load		0.765		
Mounting	B35		100% Load		0.815		
Bearing	Type	Anti-Friction	Speed at Full Load				1775 r.p.m
	DE/N-DE	6309ZC3 / 6309ZC3	Torque				
	Lubricant	Grease(Polyrex-EM)	Full Load		59.5 lb.ft		
External Thrust	Not applicable		Locked-rotor**		200 %		
Coupling Method	<input checked="" type="checkbox"/> Direct <input type="checkbox"/> V-belt		Breakdown**		240 %		
Shaft Extension	Single		Moment of Inertia (J)				
Terminal Box	Main	Cast Iron	Load(Max.)		122.210 lb.ft2		
	Aux.	No	Motor		2.635 lb.ft2		
Location	Refer to Outline Drawing		Sound Pressure Level (No-load & mean value at 1m from motor)				
			70 dB(A)				
Application			Vibration				3.8 mm/sec (peak)
Area classification	Hazardous		Permissible number of consecutive starts		Cold      3 times		
Type of Ex-Protection	Class I&II, Division 2				Hot      2 times		
Applicable Standard	NEMA MG1, CSA C390		Paint	Munsell No.	4.0PB5.4/5.5(VL-451)		

ACCESSORIES	SUBMITTAL DRAWING			
	Outline Dimension Drawing \ Motor Weight(Approx.)			
	<table border="1" style="width: 100%; border-collapse: collapse;"> <tr> <td style="width: 33%;">B35</td> <td style="width: 33%;">LM-T2256C4PLV23</td> <td style="width: 33%;">310 lb.</td> </tr> </table>	B35	LM-T2256C4PLV23	310 lb.
B35	LM-T2256C4PLV23	310 lb.		

REMARK										
1. Premium efficiency according to NEMA MG1 2. Inverter Duty @ 1.0 Service Factor & F Temperature rise -. 10:1 VT (20:1 VT at 50% load) -. 10:1 CT -. CHP up to 1.5 times base speed, NEMA MG1 Part31 3. CSA Certification -. Class I, Division 2, Group A, B, C & D -. Class II, Division 2 Group E, F & G (Group E : up to 320Fr.) 4. Service Factor 1.15 and Temperature rise B are applicable under the condition of sine wave power. 5. Service Factor 1.25 is applicable to motors of 100HP or less with temperature rise F & Non-Hazardous.										
<table border="1" style="width: 100%; border-collapse: collapse;"> <tr> <td style="width: 15%;">Date</td> <td style="width: 15%;">DSND</td> <td style="width: 15%;">CHKD</td> <td style="width: 15%;">CHKD</td> <td style="width: 15%;">APPD</td> </tr> <tr> <td>2024-09-10</td> <td>S.H. Lee</td> <td>I.K. Kim</td> <td>R.G. Kim</td> <td>S.W. Kim</td> </tr> </table>	Date	DSND	CHKD	CHKD	APPD	2024-09-10	S.H. Lee	I.K. Kim	R.G. Kim	S.W. Kim
Date	DSND	CHKD	CHKD	APPD						
2024-09-10	S.H. Lee	I.K. Kim	R.G. Kim	S.W. Kim						

[Note] Others not mentioned in this data sheet shall be in accordance with maker standard.  
 Above technical data are only design values and shall be guaranteed with tolerance of applicable standard.  
 Inspection and performance test shall be done according to maker standard, if not mentioned.  
 \* In case of Inverter-Fed Motor, performance data is based on sine wave tests. It may be different from test data of Inverter combined motor.  
 \*\* Data is based on rated voltage & frequency and is expressed as a percentage of full-load value.

1	2	3	4
REV	DATE	CONTENTS	REVD BY CHKD BY CHKD BY APPD BY

4.72

**CROWN TRITON G2**  
Premium Efficiency AC 3 Phase Motor

20HP	4P	230/460V	Cat. No.	HES20-18-256TC						
Model	HLS256PR23		INS. Class	F	HD-F1	Amps	49.7/24.8			
Type	HLS	Duty	CONT	Code	J	Amb.	40°C	Hertz	60Hz	
Frame	256TC	Encl.	TEFC	S.F.	1.15	RPM	1775	NEMA Nom. Eff.	93%	
Bearing	Drive	6309ZC3		S.F.1.25 (When 100HP or less, Temp Rise F & Non-Hazardous)		3/4 Eff.	92%			
	Opp.	6309ZC3		S.F.1.00 (10:1 C.T., 20:1 V.T., NEMA-MG1 Part31)		NEMA Design	B Torque			
Usable at	50Hz 20HP 380V 33.59A 1470rpm S.F.: 1.15 Eff.: 91% Code: H									
	50Hz 20HP 400/415V 32.98/32.98A 1470/1475rpm S.F.: 1.15 Eff.: 91/91% Code: J/K									
CSA Certified for	Model	LATER		Type	PJP	Temp. Code	Frame	140~320FR	360~400FR	440FR
	CLASS I, Div. 2, Gr. A, B, C & D		CLASS II, Div. 2 Gr. E, F & G (Gr. E: Up to 320FR)			(sine wave)	Amb. 40°C	T3C (160°C)	T3B (165°C)	T3A (180°C)
CLASS I, Zone 2, Gr. IIA, IIB, & IIC						Amb. 55°C	T3A (180°C)	T3A (180°C)	T3 (200°C)	
No.	-			Date	-		Weight	310 lb		

4M-136024  
**MARINE DUTY IEEEE45**

Made in Vietnam H4  
Designed By HYUNDAI, Korea

2.36

APPD BY	S.Y.KIM	UNIT	INCH	SUBJECT	CSA Class I, Division2 Severe Duty (HES, 254-326)	DWG SIZE
CHKD BY	I.K.KIM	SCALE	NONE			A4 ( 1:1 )
CHKD BY	R.G.KIM	PROJEC'N	3rd Angle	NAMEPLATE DRAWING		
DSND BY	S.H.LEE	DATE	2024.06.07			
				REF. NO	4M-136024	Sheet No. of
				DWG NO	NP-HES20-18-256TC	Revision No. 0



# PERFORMANCE CURVE

CURVE NO.  
PC-HES20-18-256TC

Type :	PJP	15kW	20HP	4 P	60 Hz	
Full Load Torque :	59.5 lb.ft	Speed at Full Load : 1775 RPM				
Load moment of Inertia (J) :	122.210 lb.ft2	Rated Voltage		575V	460V	230V
Motor moment of Inertia (J) :	2.635 lb.ft2	Full Load Current		19.9A	24.8A	49.7A

SPEED VS TORQUE & CURRENT CURVE

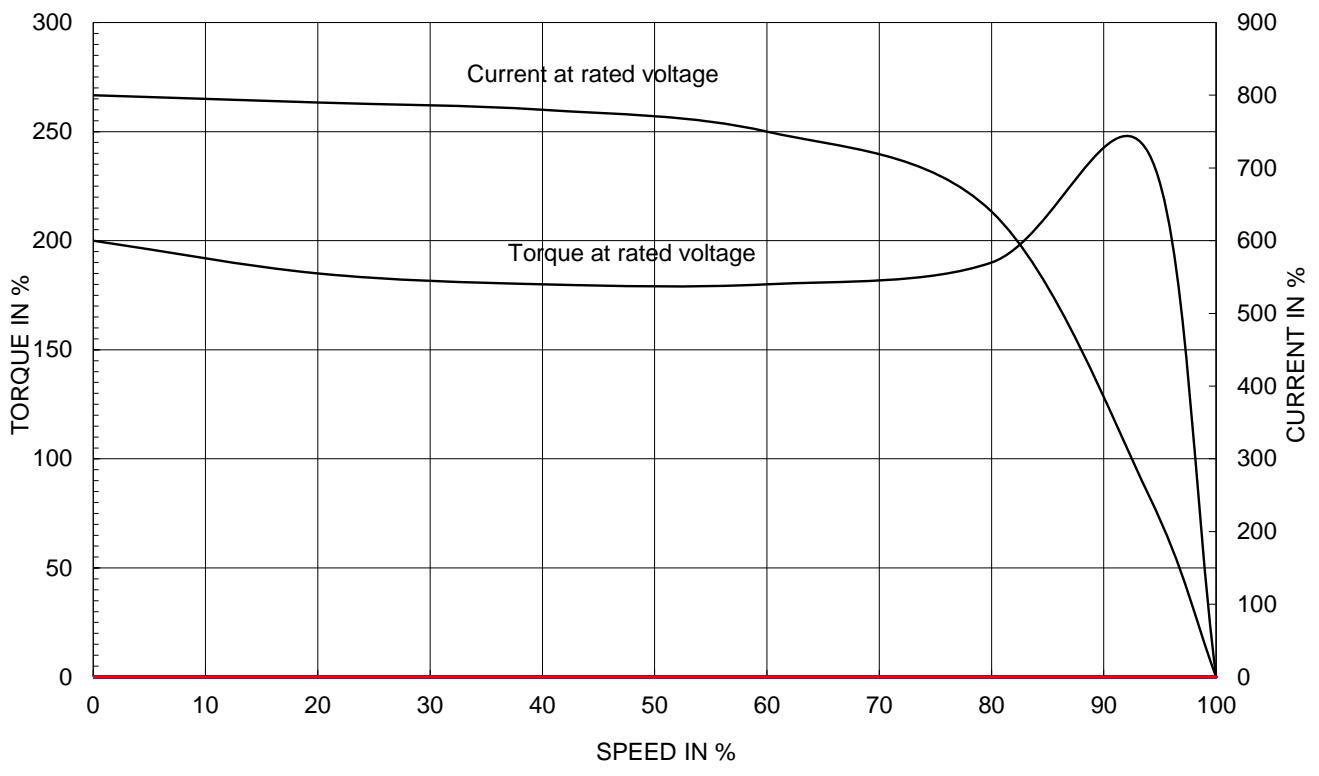

OUTPUT VS EFF., P.F & CURRENT CURVE

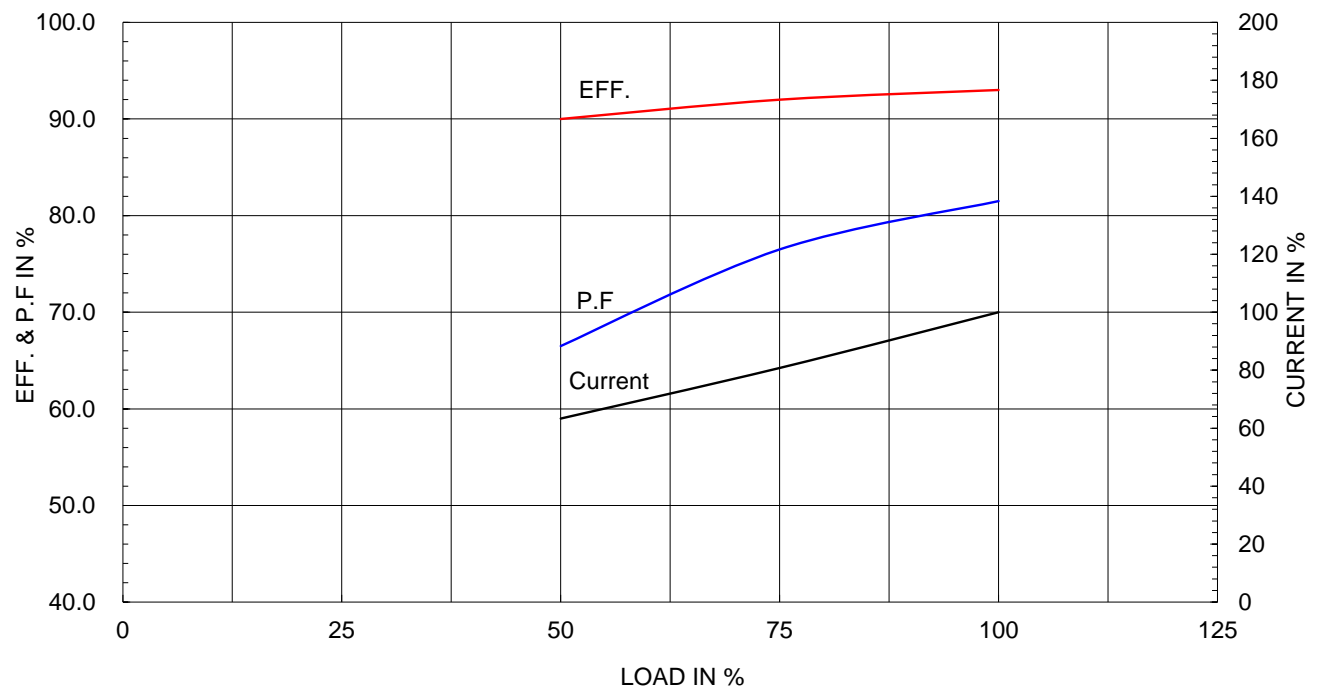

본 도면은 HD현대일렉트릭(주) 재산이며 허가없이 복사할 수 없음 (취급유의)

THIS DRAWING IS PROPRIETARY TO HYUNDAI ELECTRIC. NO PART OF THIS DRAWING MAYBE REPRODUCED WITHOUT THE PERMISSION OF HYUNDAI ELECTRIC.

▽	50S	REV	DATE	CONTENTS	REVD BY	CHKD BY	CHKD BY	APPD BY
▽▽	12.5S							
▽▽▽	3.2S							
▽▽▽▽	0.4S							

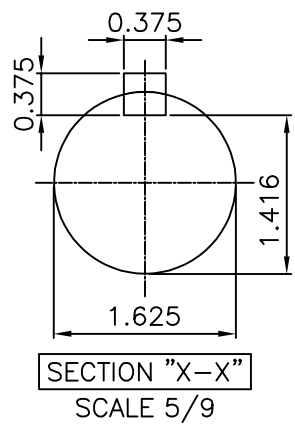
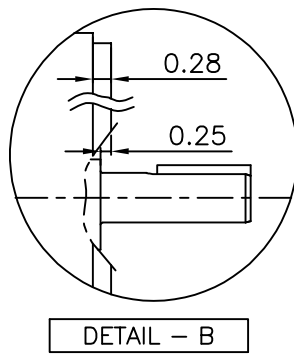
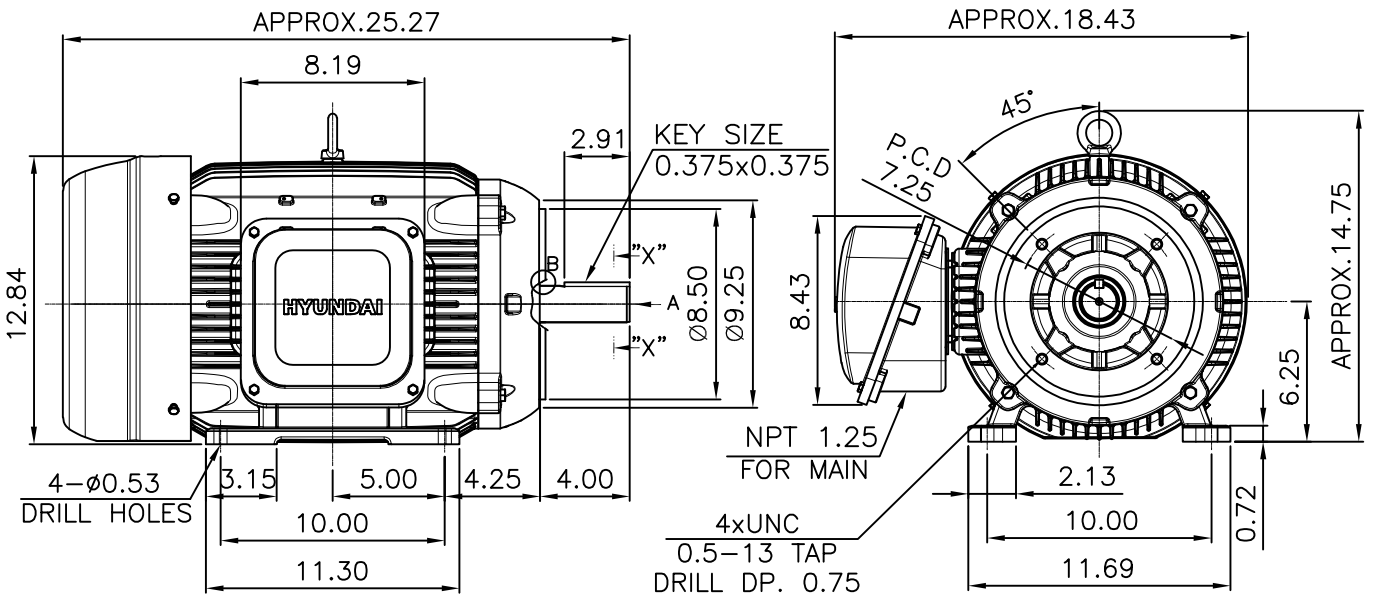

**NOTE**

[TOLERANCE]

1. CENTER HEIGHT : +0.00inch - 0.03inch
2. SHAFT DIAMETER : +0.000inch - 0.001inch
3. KEYWAY DEPTH : +0.000inch - 0.015inch

APPD BY	S.Y.KIM	UNIT	inch	SUBJECT	NEMA 256TC	DWG SIZE	A4 ( 1:9 )
CHKD BY	R.G.KIM	SCALE	1/9	TITLE	OUTLINE	REF. NO	Sheet No. of
CHKD BY		PROJEC'N	3rd Angle				
DSND BY	전지현	DATE	2021-04-29				
				DWG NO	LM-T2256C4PLV23	Revision No. 0	



# Cls. I&II, Div. 2 IEEE 841



▽	50S
▽▽	12.5S
▽▽▽	3.2S
▽▽▽▽	0.4S

REV	DATE	CONTENTS	REVD BY	CHKD BY	CHKD BY	APPD BY

일반가공공차		일반제관공차	
1-4	±0.1	6-30	±0.5
4-18	±0.2	30-120	±0.8
18-63	±0.3	120-315	±1.2
63-250	±0.5	315-1000	±2.0
250-	±0.8	1000-	±3.0

Q'TY	DESCRIPTION	MATERIAL	DIMENSION	WEIGHT	PART NO.	REMARK	NO.
APPD BY	S.Y.KIM	UNIT	inch(mm)	SUBJECT	FR. 250-280 (CAST IRON)	DWG SIZE	
CHKD BY		SCALE	1/2	TITLE	TERMINAL BOX ASS'Y		
CHKD BY	R.G.KIM	PROJEC'N	3rd Angle	DATE	2023-10-19		
DSND BY	배승희						
REF. NO		Sheet No.	of				
DWG NO	3M-248458	Revision No.	0				

