

Customer :
 Project Name :
 Project No. :
 Revision No. :

SPECIFICATION for INDUCTION MOTOR



0		For Bidding			
No.	DATE	DESCRIPTION	PREPARED BY	CHECKED BY	APPROVED BY



AC INDUCTION MOTOR DATA SHEET

Catalog No.	HES2-36-145TC	Item No.		Rev. No.	[]
Project Name		Project No.		Quantity	sets

GENERAL SPECIFICATION			PERFORMANCE DATA			
Frame Size	145TC		Rated Output	1.5 kW		2 HP
Type	PJP		Number of Poles	2		
Enclosure(Protection)	Totally Enclosed	/ IP55	Rotor Type	Squirrel Cage		
Method of Cooling	IC411(FC)		Starting Method*	D.O.L		
Rated Frequency	60 Hz		Rated Voltage	575 V	460 V	230 V
Number of Phases	3		Current	Full Load	2.07 A	2.59 A
Insulation Class	F			Locked-rotor**	950 %	950 %
Temp. Rise at full load (by resistance method)			Efficiency			
at 1.0 S.F	80 deg. C		50% Load		82.5 %	
Motor Location	<input type="checkbox"/> Indoor <input type="checkbox"/> Outdoor		75% Load		84.5 %	
Altitude	Less than 1,000 meter		100% Load		85.5 %	
Relative Humidity	Less than 80 %		Power Factor(p.u)			
Ambient Temp.	40 deg. C (Max.)		50% Load		0.700	
Duty Type	Continuous (S1)		75% Load		0.800	
Service Factor	1.15		100% Load		0.850	
Mounting	B35		Speed at Full Load	3480 r.p.m		
Bearing	Type	Anti-Friction	Torque			
	DE/N-DE	6205ZZC3 / 6204ZZC3	Full Load	3.0 lb.ft		
	Lubricant	Grease(Polyrex-EM)	Locked-rotor**	180 %		
External Thrust	Not applicable		Breakdown**	250 %		
Coupling Method	<input checked="" type="checkbox"/> Direct <input type="checkbox"/> V-belt		Moment of Inertia (J)			
Shaft Extension	Single		Load(Max.)	2.729 lb.ft2		
Terminal Box	Main	Cast Iron	Motor	0.042 lb.ft2		
	Aux.	No	Sound Pressure Level (No-load & mean value at 1m from motor)			
Location	Refer to Outline Drawing				69 dB(A)	
Application			Vibration		3.8 mm/sec (peak)	
Area classification	Hazardous		Permissible number of consecutive starts	Cold	3 times	
Type of Ex-Protection	Class I&II, Division 2			Hot	2 times	
Applicable Standard	NEMA MG1, CSA C390		Paint	Munsell No.	4.0PB5.4/5.5(VL-451)	

ACCESSORIES

SPARE PARTS

SUBMITTAL DRAWING







Outline Dimension Drawing		Motor Weight(Approx.)	
B35	LM-T2145C4PLV23	65 lb.	

REMARK

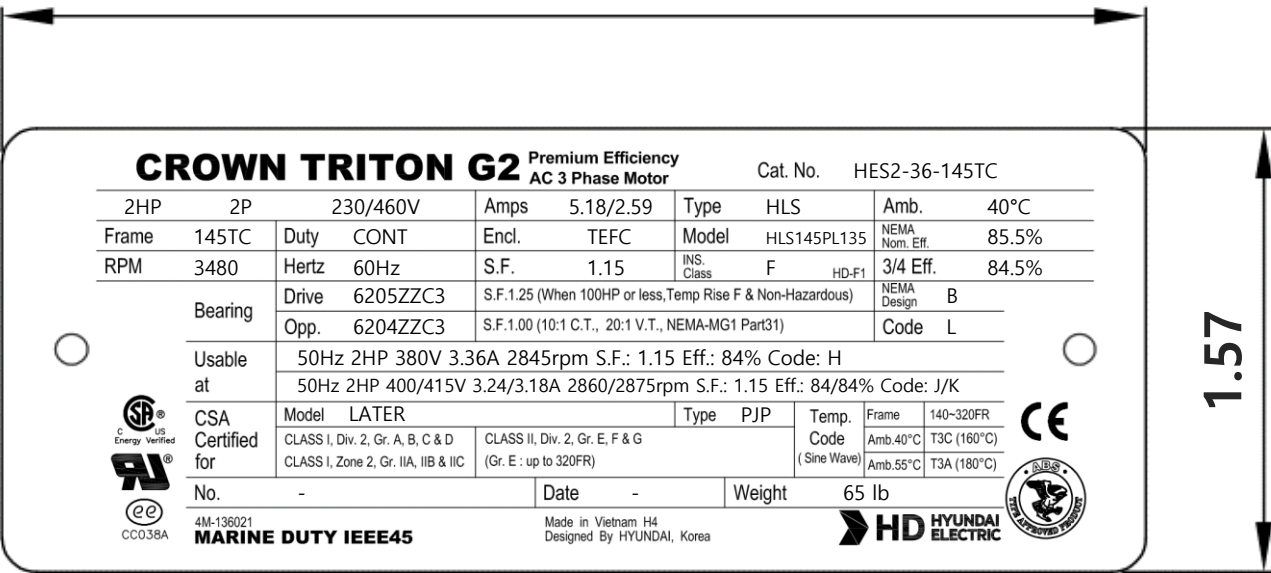
1. Premium efficiency according to NEMA MG1
2. Inverter Duty @ 1.0 Service Factor & F Temperature rise
 - 10:1 VT (20:1 VT at 50% load)
 - 10:1 CT
 - CHP up to 1.5 times base speed, NEMA MG1 Part31
3. CSA Certification
 - Class I, Division 2, Group A, B, C & D
 - Class II, Division 2 Group E, F & G (Group E : up to 320Fr.)
4. Service Factor 1.15 and Temperature rise B are applicable under the condition of sine wave power.
5. Service Factor 1.25 is applicable to motors of 100HP or less with temperature rise F & Non-Hazardous.

Date	DSND	CHKD	CHKD	APPD
2024-09-10	S.H. Lee	I.K. Kim	R.G. Kim	S.W. Kim

[Note] Others not mentioned in this data sheet shall be in accordance with maker standard.
 Above technical data are only design values and shall be guaranteed with tolerance of applicable standard.
 Inspection and performance test shall be done according to maker standard, if not mentioned.
 * In case of Inverter-Fed Motor, performance data is based on sine wave tests. It may be different from test data of Inverter combined motor.
 ** Data is based on rated voltage & frequency and is expressed as a percentage of full-load value.

1		2		3		4																																																																																													
REV	DATE	CONTENTS		REVD BY	CHKD BY	CHKD BY	APPD BY																																																																																												
<p>3.94</p> 																																																																																																			
<p>CROWN TRITON G2 Premium Efficiency AC 3 Phase Motor Cat. No. HES2-36-145TC</p> <table border="1"> <tr> <td>2HP</td> <td>2P</td> <td>230/460V</td> <td>Amps</td> <td>5.18/2.59</td> <td>Type</td> <td>HLS</td> <td>Amb.</td> <td>40°C</td> </tr> <tr> <td>Frame</td> <td>145TC</td> <td>Duty</td> <td>CONT</td> <td>Encl.</td> <td>TEFC</td> <td>Model</td> <td>HLS145PL135</td> <td>NEMA Nom. Eff.</td> <td>85.5%</td> </tr> <tr> <td>RPM</td> <td>3480</td> <td>Hertz</td> <td>60Hz</td> <td>S.F.</td> <td>1.15</td> <td>INS Class</td> <td>F HD-F1</td> <td>3/4 Eff.</td> <td>84.5%</td> </tr> <tr> <td rowspan="2">Bearing</td> <td>Drive</td> <td>6205ZZC3</td> <td colspan="4">S.F.1.25 (When 100HP or less, Temp Rise F & Non-Hazardous)</td> <td>NEMA Design</td> <td colspan="2">B</td> </tr> <tr> <td>Opp.</td> <td>6204ZZC3</td> <td colspan="4">S.F.1.00 (10:1 C.T., 20:1 V.T., NEMA-MG1 Part31)</td> <td>Code</td> <td colspan="2">L</td> </tr> <tr> <td rowspan="2">Usable at</td> <td colspan="8">50Hz 2HP 380V 3.36A 2845rpm S.F.: 1.15 Eff.: 84% Code: H</td> </tr> <tr> <td colspan="8">50Hz 2HP 400/415V 3.24/3.18A 2860/2875rpm S.F.: 1.15 Eff.: 84/84% Code: J/K</td> </tr> <tr> <td rowspan="2">CSA Certified for</td> <td>Model</td> <td colspan="2">LATER</td> <td>Type</td> <td>PJP</td> <td>Temp. Code</td> <td>Frame</td> <td>140-320FR</td> </tr> <tr> <td colspan="2">CLASS I, Div. 2, Gr. A, B, C & D</td> <td colspan="3">CLASS II, Div. 2, Gr. E, F & G (Gr. E : up to 320FR)</td> <td>(Sine Wave)</td> <td>Amb.40°C</td> <td>T3C (160°C)</td> <td>CE</td> </tr> <tr> <td>No.</td> <td colspan="2">-</td> <td>Date</td> <td colspan="2">-</td> <td>Weight</td> <td colspan="2">65 lb</td> </tr> </table> <p>      </p> <p>4M-136021 Made in Vietnam H4 DESIGNED BY HYUNDAI, KOREA</p> <p>MARINE DUTY IEEE45</p> <p style="text-align: right;">1.57</p>								2HP	2P	230/460V	Amps	5.18/2.59	Type	HLS	Amb.	40°C	Frame	145TC	Duty	CONT	Encl.	TEFC	Model	HLS145PL135	NEMA Nom. Eff.	85.5%	RPM	3480	Hertz	60Hz	S.F.	1.15	INS Class	F HD-F1	3/4 Eff.	84.5%	Bearing	Drive	6205ZZC3	S.F.1.25 (When 100HP or less, Temp Rise F & Non-Hazardous)				NEMA Design	B		Opp.	6204ZZC3	S.F.1.00 (10:1 C.T., 20:1 V.T., NEMA-MG1 Part31)				Code	L		Usable at	50Hz 2HP 380V 3.36A 2845rpm S.F.: 1.15 Eff.: 84% Code: H								50Hz 2HP 400/415V 3.24/3.18A 2860/2875rpm S.F.: 1.15 Eff.: 84/84% Code: J/K								CSA Certified for	Model	LATER		Type	PJP	Temp. Code	Frame	140-320FR	CLASS I, Div. 2, Gr. A, B, C & D		CLASS II, Div. 2, Gr. E, F & G (Gr. E : up to 320FR)			(Sine Wave)	Amb.40°C	T3C (160°C)	CE	No.	-		Date	-		Weight	65 lb	
2HP	2P	230/460V	Amps	5.18/2.59	Type	HLS	Amb.	40°C																																																																																											
Frame	145TC	Duty	CONT	Encl.	TEFC	Model	HLS145PL135	NEMA Nom. Eff.	85.5%																																																																																										
RPM	3480	Hertz	60Hz	S.F.	1.15	INS Class	F HD-F1	3/4 Eff.	84.5%																																																																																										
Bearing	Drive	6205ZZC3	S.F.1.25 (When 100HP or less, Temp Rise F & Non-Hazardous)				NEMA Design	B																																																																																											
	Opp.	6204ZZC3	S.F.1.00 (10:1 C.T., 20:1 V.T., NEMA-MG1 Part31)				Code	L																																																																																											
Usable at	50Hz 2HP 380V 3.36A 2845rpm S.F.: 1.15 Eff.: 84% Code: H																																																																																																		
	50Hz 2HP 400/415V 3.24/3.18A 2860/2875rpm S.F.: 1.15 Eff.: 84/84% Code: J/K																																																																																																		
CSA Certified for	Model	LATER		Type	PJP	Temp. Code	Frame	140-320FR																																																																																											
	CLASS I, Div. 2, Gr. A, B, C & D		CLASS II, Div. 2, Gr. E, F & G (Gr. E : up to 320FR)			(Sine Wave)	Amb.40°C	T3C (160°C)	CE																																																																																										
No.	-		Date	-		Weight	65 lb																																																																																												
APPD BY	S.Y.KIM	UNIT	INCH	SUBJECT	CSA Class I, Division2 Severe Duty (HES, 143-215)		DWG SIZE																																																																																												
CHKD BY	I.K.KIM	SCALE	NONE	TITLE		A4 (1:1)																																																																																													
CHKD BY	R.G.KIM	PROJEC'N	3rd Angle	<p>NAMEPLATE DRAWING</p>																																																																																															
DSND BY	S.H.LEE	DATE	2024.06.07																																																																																																
				REF. NO	4M-136021		Sheet No. of																																																																																												
				DWG NO	NP-HES2-36-145TC		Revision No. 0																																																																																												
1		2		3		4																																																																																													



PERFORMANCE CURVE

CURVE NO.

PC-HES2-36-145TC

Type :	PJP
Full Load Torque :	3.0 lb.ft
Load moment of Inertia (J) :	2.729 lb.ft ²
Motor moment of Inertia (J) :	0.042 lb.ft ²

1.5kW	2HP	2 P	60 Hz
Speed at Full Load :			3480 RPM
Rated Voltage	575V	460V	230V
Full Load Current	2.1A	2.6A	5.2A

SPEED VS TORQUE & CURRENT CURVE

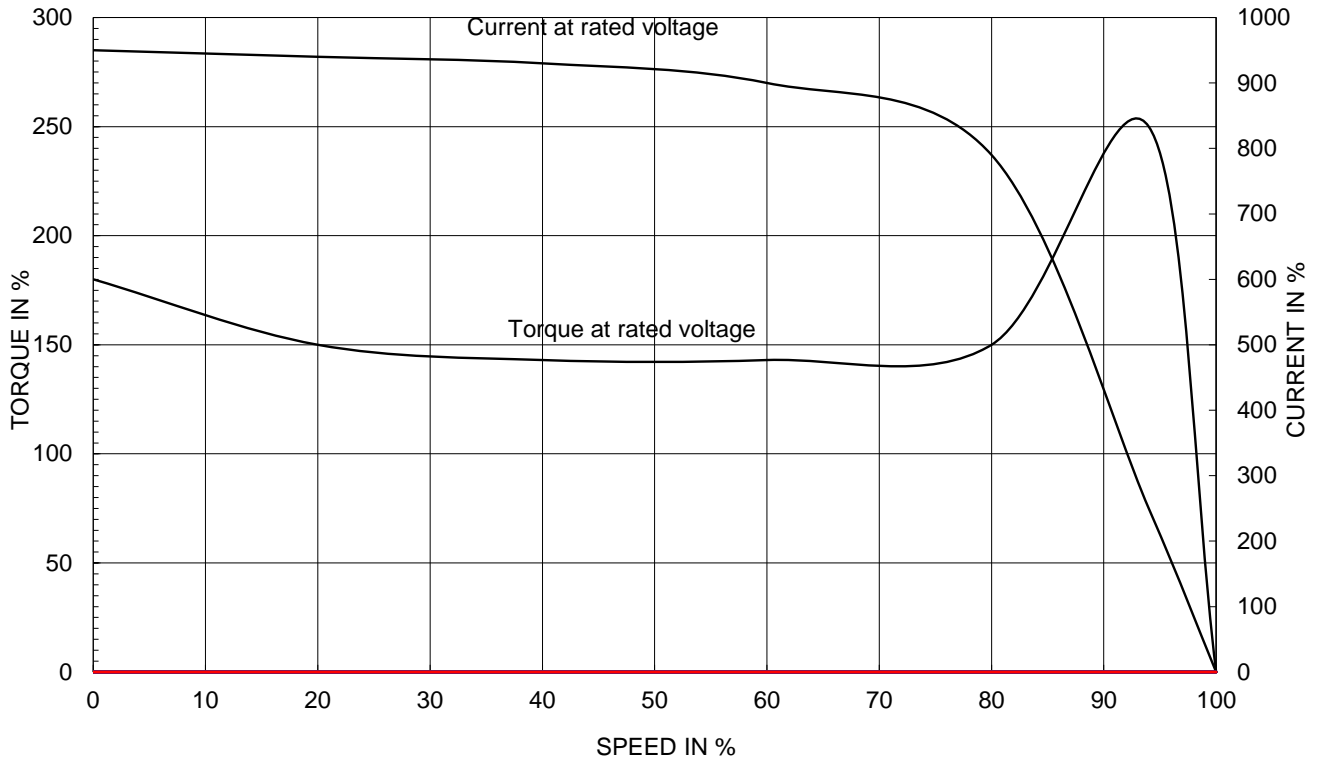

OUTPUT VS EFF., P.F & CURRENT CURVE

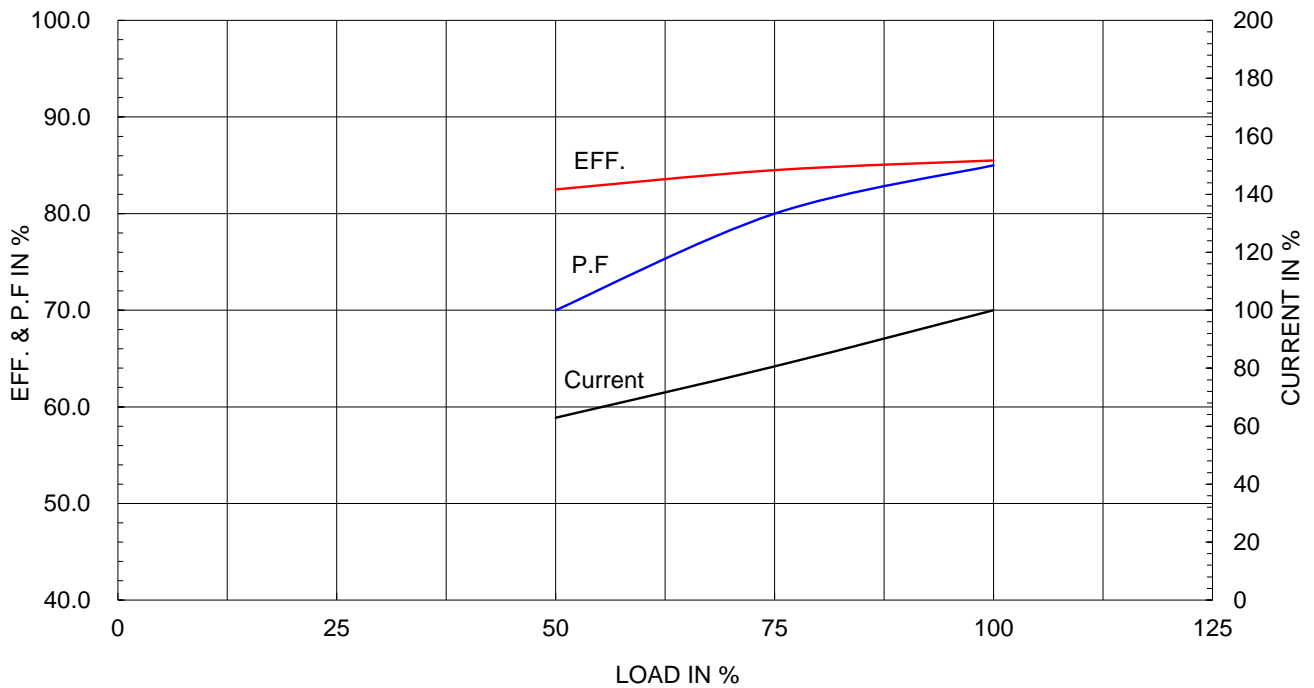

본 도면은 HD현대일렉트릭(주) 재산이며 허가없이 복사할 수 없음 (취급유의)

THIS DRAWING IS PROPRIETARY TO HYUNDAI ELECTRIC. NO PART OF THIS DRAWING MAYBE REPRODUCED WITHOUT THE PERMISSION OF HYUNDAI ELECTRIC.

▽	50S	REV	DATE	CONTENTS	REVD BY	CHKD BY	CHKD BY	APPD BY
▽▽	12.5S							
▽▽▽	3.2S							
▽▽▽▽	0.4S							

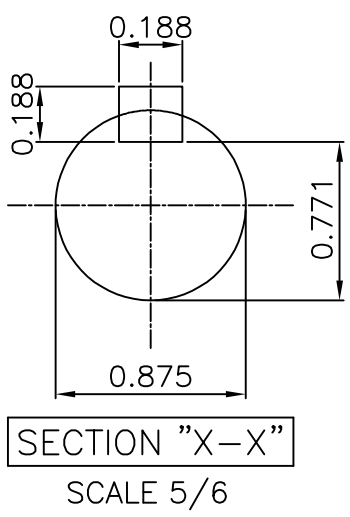
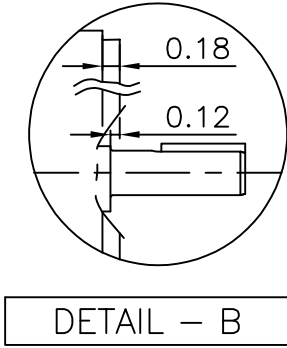
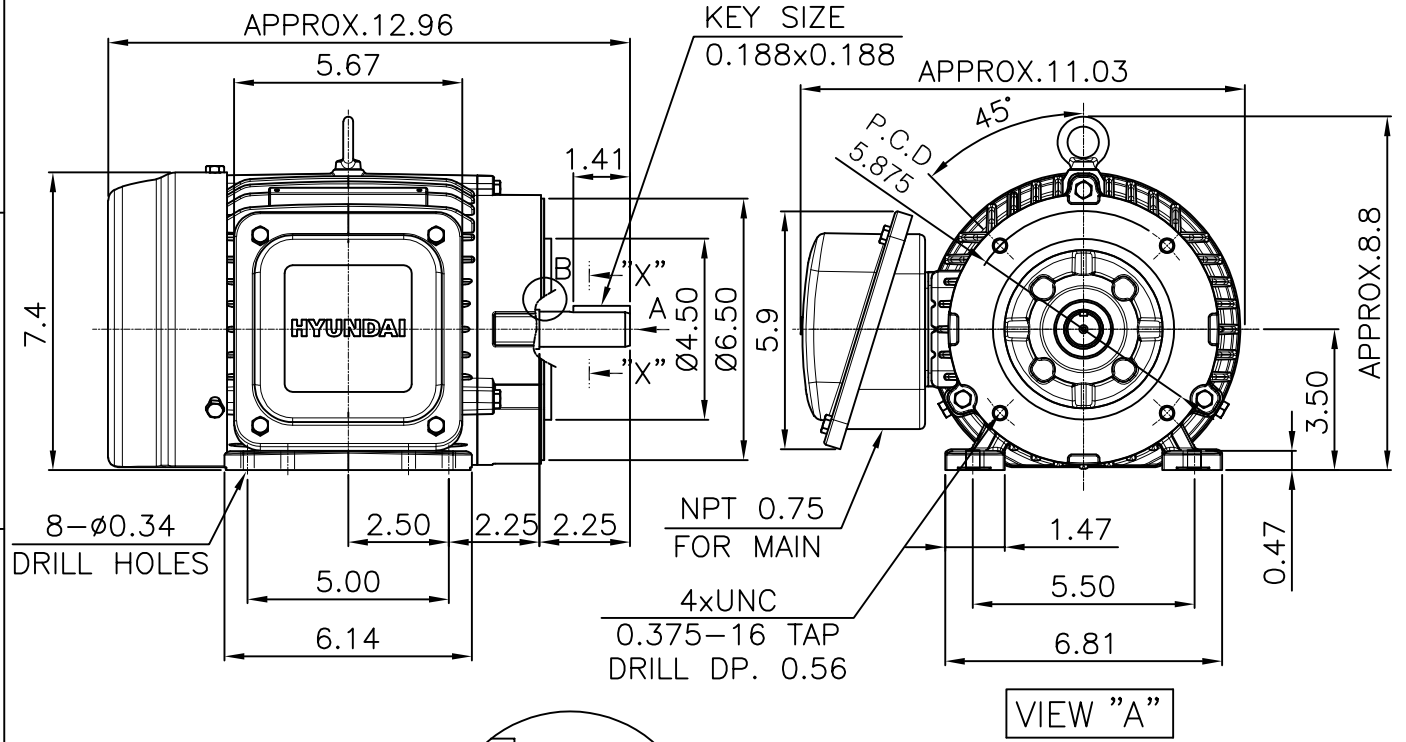

- NOTE**
[TOLERANCE]
- CENTER HEIGHT : +0.00inch - 0.03inch
 - SHAFT DIAMETER : +0.000inch - 0.0005inch
 - KEYWAY DEPTH : +0.000inch - 0.015inch

APPD BY	S.Y.KIM	UNIT	inch	SUBJECT	NEMA 145TC	DWG SIZE	A4 (1:5)
CHKD BY	R.G.KIM	SCALE	1/5	TITLE	OUTLINE	Sheet No. of	
CHKD BY		PROJEC'N	3rd Angle			Revision No. 0	
DSND BY	주유림	DATE	2021-04-29				
				REF. NO		Sheet No. of	
				DWG NO	LM-T2145C4PLV23	Revision No. 0	



**Cls. I&II, Div. 2
IEEE 841**

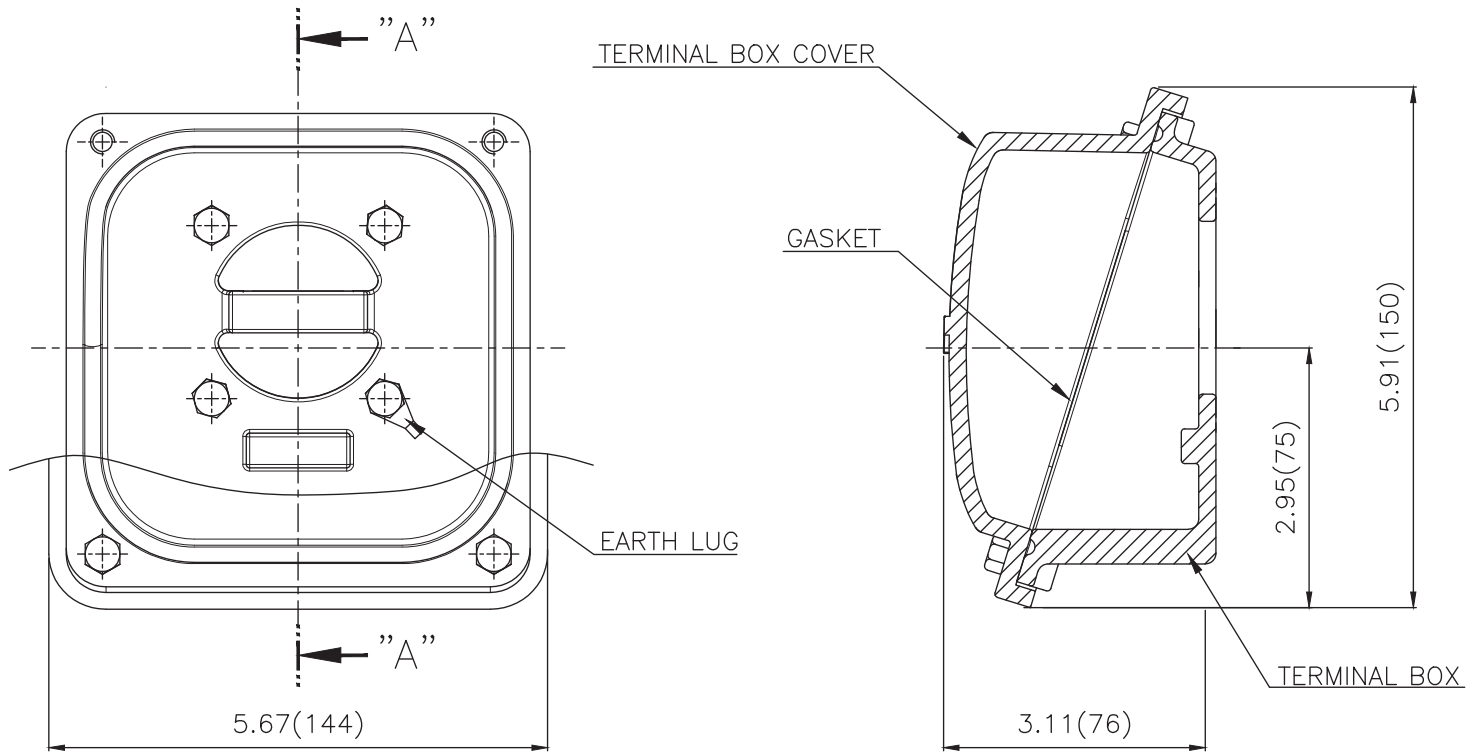

SEC. "A"-"A"

▽	50S
▽▽	12.5S
▽▽▽	3.2S
▽▽▽▽	0.4S

REV	DATE	CONTENTS	REVD BY	CHKD BY	CHKD BY	APPD BY

일반가공공차		일반제관공차	
1-4	±0.1	6-30	±0.5
4-18	±0.2	30-120	±0.8
18-63	±0.3	120-315	±1.2
63-250	±0.5	315-1000	±2.0
250-	±0.8	1000-	±3.0

Q'TY	DESCRIPTION	MATERIAL	DIMENSION	WEIGHT	PART NO.	REMARK	NO.
APPD BY	S.Y.KIM	UNIT	inch(mm)	SUBJECT	FR. 140-180 (CAST IRON)	DWG SIZE	A3 (1:1.5)
CHKD BY		SCALE	1/1.5	TITLE			
CHKD BY	R.G.KIM	PROJEC'N	3rd Angle	TERMINAL BOX ASS'Y			
DSND BY	배승희	DATE	2023-10-19	REF. NO		Sheet No.	of
				DWG NO	3M-248456	Revision No.	0

