

Customer :
 Project Name :
 Project No. :
 Revision No. :

SPECIFICATION for INDUCTION MOTOR



0		For Bidding			
No.	DATE	DESCRIPTION	PREPARED BY	CHECKED BY	APPROVED BY



AC INDUCTION MOTOR DATA SHEET

Catalog No.	HES2-18-145TC	Item No.		Rev. No.	[]
Project Name		Project No.		Quantity	sets

GENERAL SPECIFICATION			PERFORMANCE DATA			
Frame Size	145TC		Rated Output	1.5 kW 2 HP		
Type	PJP		Number of Poles	4		
Enclosure(Protection)	Totally Enclosed	/	IP55	Rotor Type	Squirrel Cage	
Method of Cooling	IC411(FC)		Starting Method*	D.O.L		
Rated Frequency	60 Hz		Rated Voltage	575 V	460 V	230 V
Number of Phases	3		Current	Full Load	2.39 A	2.98 A
Insulation Class	F			Locked-rotor**	830 %	830 %
Temp. Rise at full load (by resistance method)			Efficiency			
at 1.0 S.F	80 deg. C		50% Load 83.5 %			
Motor Location	<input type="checkbox"/> Indoor <input type="checkbox"/> Outdoor		75% Load 85.5 %			
Altitude	Less than 1,000 meter		100% Load 86.5 %			
Relative Humidity	Less than 80 %		Power Factor(p.u)			
Ambient Temp.	40 deg. C (Max.)		50% Load 0.580			
Duty Type	Continuous (S1)		75% Load 0.680			
Service Factor	1.15		100% Load 0.730			
Mounting	B35		Speed at Full Load	1745 r.p.m		
Bearing	Type	Anti-Friction		Torque		
	DE/N-DE	6205ZZC3 / 6204ZZC3		Full Load	6.1 lb.ft	
	Lubricant	Grease(Polyrex-EM)		Locked-rotor**	245 %	
External Thrust	Not applicable		Breakdown**	280 %		
Coupling Method	<input checked="" type="checkbox"/> Direct <input type="checkbox"/> V-belt		Moment of Inertia (J)			
Shaft Extension	Single		Load(Max.) 15.365 lb.ft2			
Terminal Box	Main	Cast Iron		Motor 0.078 lb.ft2		
	Aux.	No		Sound Pressure Level (No-load & mean value at 1m from motor)		
	Location	Refer to Outline Drawing		56 dB(A)		
Application			Vibration 3.8 mm/sec (peak)			
Area classification	Hazardous		Permissible number of consecutive starts			
Type of Ex-Protection	Class I&II, Division 2		Cold 3 times			
Applicable Standard	NEMA MG1, CSA C390		Hot 2 times			
			Paint	Munsell No.	4.0PB5.4/5.5(VL-451)	

ACCESSORIES

SUBMITTAL DRAWING			
Outline Dimension Drawing		Motor Weight(Approx.)	
B35	LM-T2145C4PLV23	65 lb.	

SPARE PARTS

REMARK				
1. Premium efficiency according to NEMA MG1 2. Inverter Duty @ 1.0 Service Factor & F Temperature rise -. 10:1 VT (20:1 VT at 50% load) -. 10:1 CT -. CHP up to 1.5 times base speed, NEMA MG1 Part31 3. CSA Certification -. Class I, Division 2, Group A, B, C & D -. Class II, Division 2 Group E, F & G (Group E : up to 320Fr.) 4. Service Factor 1.15 and Temperature rise B are applicable under the condition of sine wave power. 5. Service Factor 1.25 is applicable to motors of 100HP or less with temperature rise F & Non-Hazardous.				
Date	DSND	CHKD	CHKD	APPD
2024-09-10	S.H. Lee	I.K. Kim	R.G. Kim	S.W. Kim

[Note] Others not mentioned in this data sheet shall be in accordance with maker standard.
 Above technical data are only design values and shall be guaranteed with tolerance of applicable standard.
 Inspection and performance test shall be done according to maker standard, if not mentioned.
 * In case of Inverter-Fed Motor, performance data is based on sine wave tests. It may be different from test data of Inverter combined motor.
 ** Data is based on rated voltage & frequency and is expressed as a percentage of full-load value.

1	2	3	4
REV	DATE	CONTENTS	REVD BY

3.94

CROWN TRITON G2 Premium Efficiency AC 3 Phase Motor

Cat. No. HES2-18-145TC

2HP	4P	230/460V	Amps	5.96/2.98	Type	HLS	Amb.	40°C
Frame	145TC	Duty	CONT	Encl.	TEFC	Model	HLS145PL235	NEMA Nom. Eff. 86.5%
RPM	1745	Hertz	60Hz	S.F.	1.15	INS Class	F HD-F1	3/4 Eff. 85.5%
Bearing	Drive	6205ZZC3 S.F.1.25 (When 100HP or less, Temp Rise F & Non-Hazardous)				NEMA Design B		
	Opp.	6204ZZC3 S.F.1.00 (10:1 C.T., 20:1 V.T., NEMA-MG1 Part31)				Code L		
Usable at	50Hz 2HP 380V 3.77A 1430rpm S.F.: 1.15 Eff.: 84% Code: J							
	50Hz 2HP 400/415V 3.72/3.72A 1440/1445rpm S.F.: 1.15 Eff.: 84/84% Code: K/K							
CSA Certified for	Model	LATER			Type	PJP	Temp. Code	Frame
	CLASS I, Div. 2, Gr. A, B, C & D		CLASS II, Div. 2, Gr. E, F & G (Gr. E : up to 320FR)			(Sine Wave)	Amb.40°C	T3C (160°C)
	CLASS I, Zone 2, Gr. IIA, IIB & IIC						Amb.55°C	T3A (180°C)
No.	-		Date	-		Weight	65 lb	





4M-136021
MARINE DUTY IEEE45

Made in Vietnam H4
Designed By HYUNDAI, Korea

1.57

APPD BY	S.Y.KIM	UNIT	INCH	SUBJECT	CSA Class I, Division2 Severe Duty (HES, 143-215)	DWG SIZE
CHKD BY	I.K.KIM	SCALE	NONE			A4 (1:1)
CHKD BY	R.G.KIM	PROJEC'N	3rd Angle	TITLE NAMEPLATE DRAWING		
DSND BY	S.H.LEE	DATE	2024.06.07			
				REF. NO	4M-136021	Sheet No. of
				DWG NO	NP-HES2-18-145TC	Revision No. 0



PERFORMANCE CURVE

CURVE NO.

PC-HES2-18-145TC

Type :	PJP
Full Load Torque :	6.1 lb.ft
Load moment of Inertia (J) :	15.365 lb.ft ²
Motor moment of Inertia (J) :	0.078 lb.ft ²

1.5kW	2HP	4 P	60 Hz
Speed at Full Load :			1745 RPM
Rated Voltage	575V	460V	230V
Full Load Current	2.4A	3.0A	6.0A

SPEED VS TORQUE & CURRENT CURVE

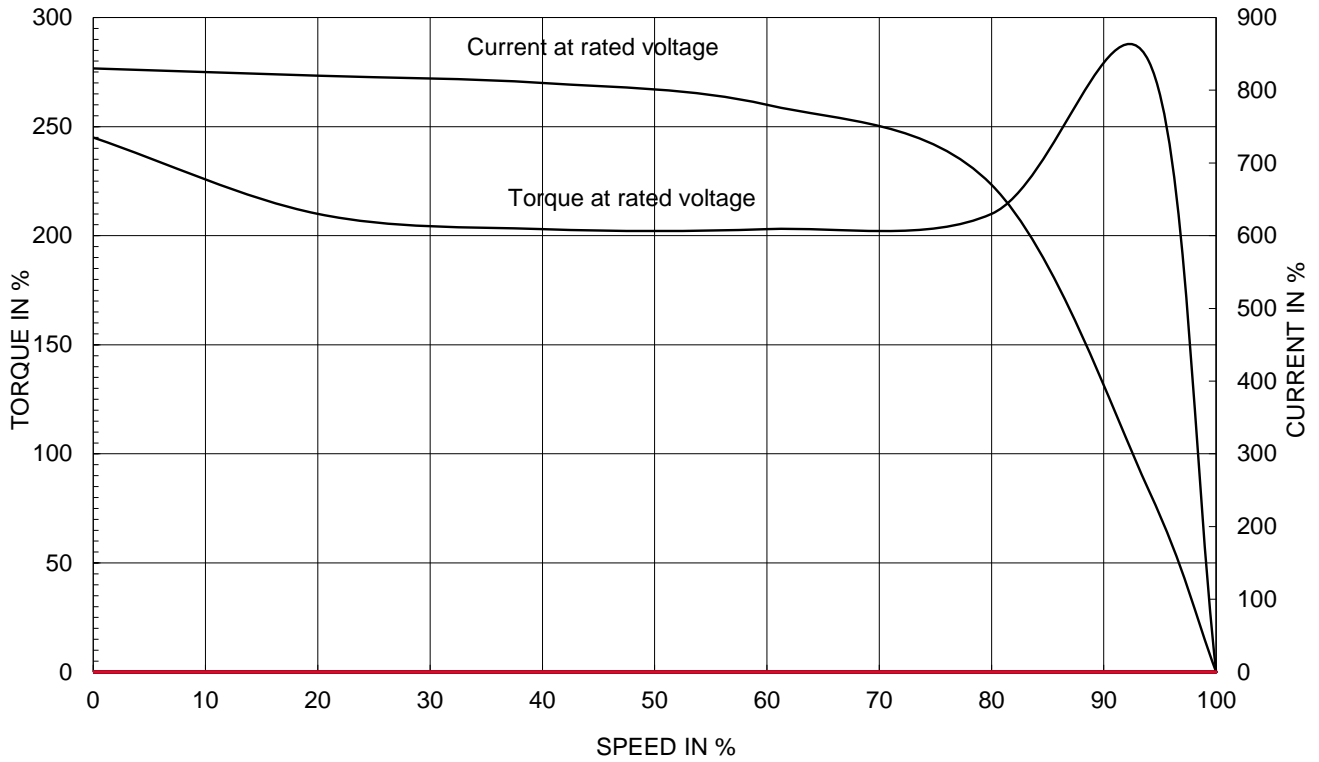

OUTPUT VS EFF., P.F & CURRENT CURVE

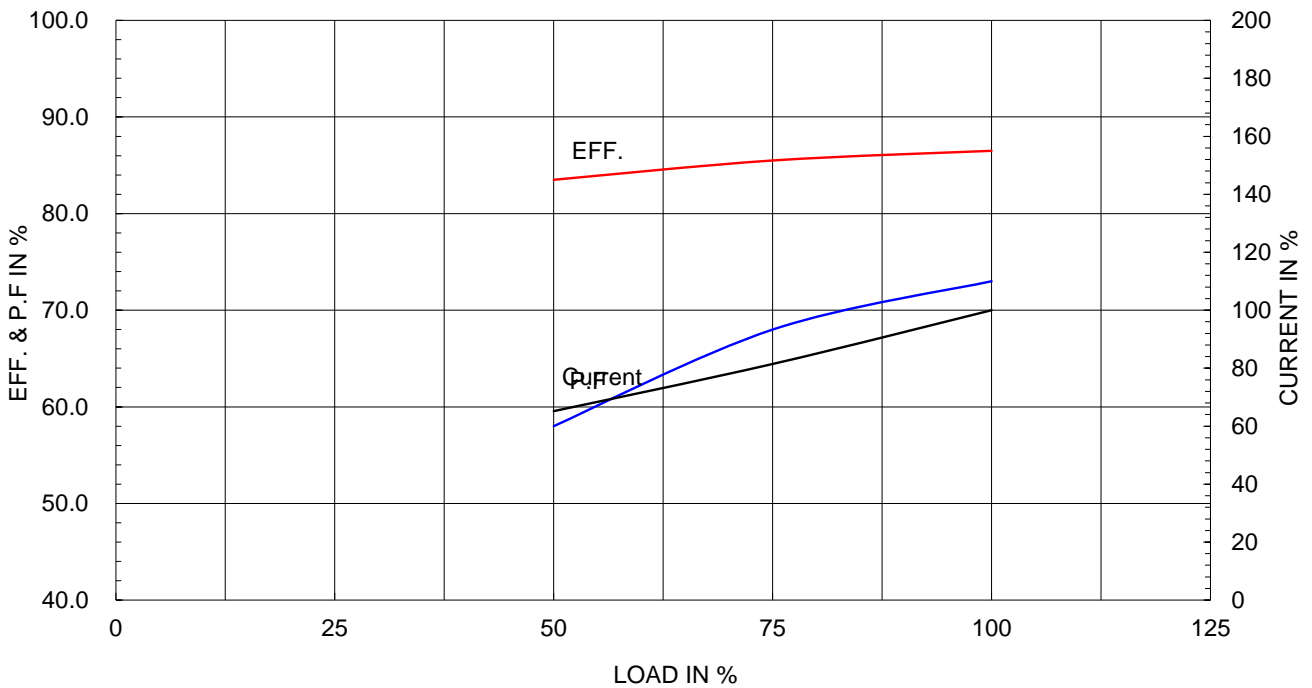



**Cls. I&II, Div. 2
IEEE 841**

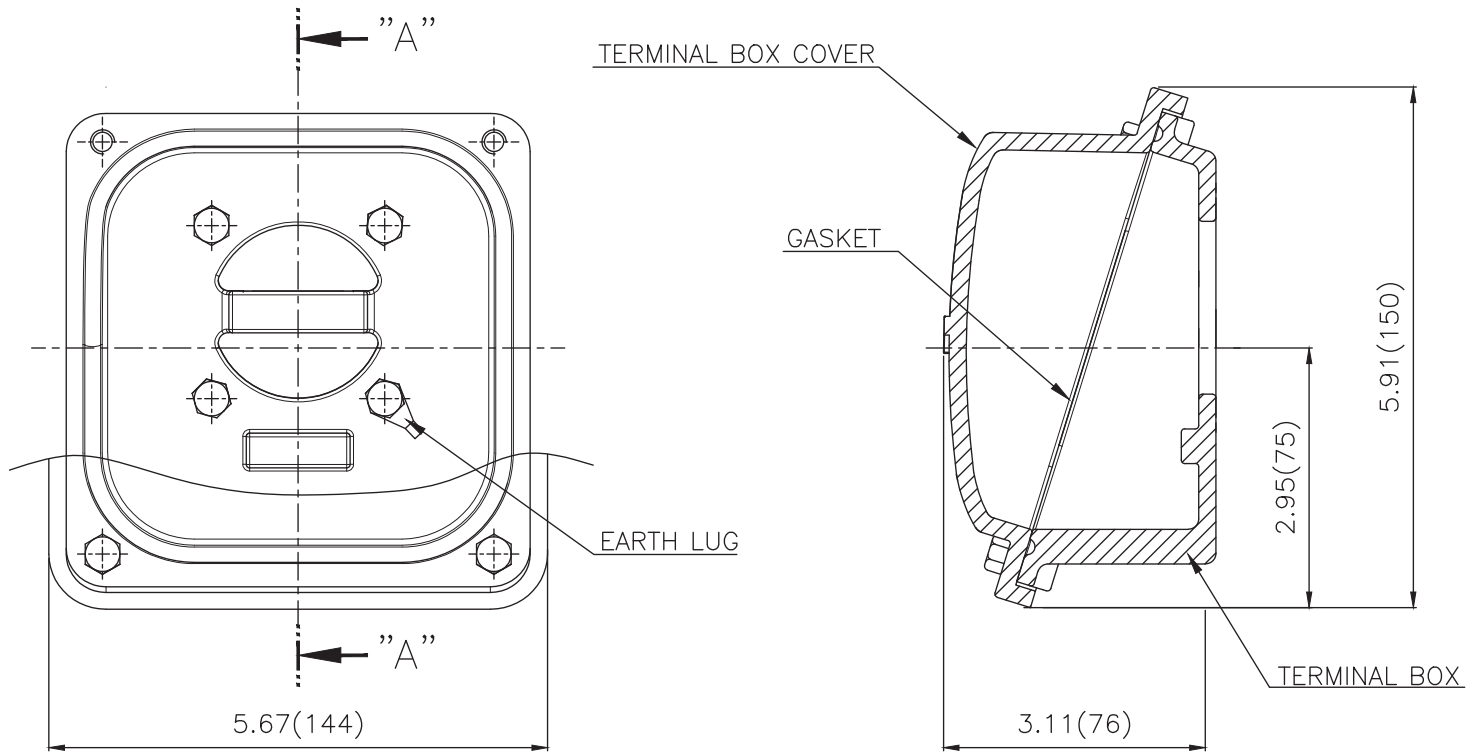

SEC. "A"-"A"

▽	50S
▽▽	12.5S
▽▽▽	3.2S
▽▽▽▽	0.4S

REV	DATE	CONTENTS	REVD BY	CHKD BY	CHKD BY	APPD BY

일반가공공차		일반제관공차	
1-4	±0.1	6-30	±0.5
4-18	±0.2	30-120	±0.8
18-63	±0.3	120-315	±1.2
63-250	±0.5	315-1000	±2.0
250-	±0.8	1000-	±3.0

Q'TY	DESCRIPTION	MATERIAL	DIMENSION	WEIGHT	PART NO.	REMARK	NO.
APPD BY	S.Y.KIM	UNIT	inch(mm)	SUBJECT	FR. 140-180 (CAST IRON)	DWG SIZE	A3 (1:1.5)
CHKD BY		SCALE	1/1.5	TITLE			
CHKD BY	R.G.KIM	PROJEC'N	3rd Angle	TERMINAL BOX ASS'Y			
DSND BY	배승희	DATE	2023-10-19	REF. NO		Sheet No.	of
				DWG NO	3M-248456	Revision No.	0