

Customer :
 Project Name :
 Project No. :
 Revision No. :

SPECIFICATION for INDUCTION MOTOR



0		For Bidding			
No.	DATE	DESCRIPTION	PREPARED BY	CHECKED BY	APPROVED BY



AC INDUCTION MOTOR DATA SHEET

Catalog No.	HES15-36-254TC	Item No.		Rev. No.	[]
Project Name		Project No.		Quantity	sets

GENERAL SPECIFICATION			PERFORMANCE DATA				
Frame Size	254TC		Rated Output	11 kW		15 HP	
Type	PJP		Number of Poles	2			
Enclosure(Protection)	Totally Enclosed / IP55		Rotor Type	Squirrel Cage			
Method of Cooling	IC411(FC)		Starting Method*	D.O.L			
Rated Frequency	60 Hz		Rated Voltage	575 V	460 V	230 V	
Number of Phases	3		Current	Full Load	13.8 A	17.2 A	
Insulation Class	F			Locked-rotor**	710 %	710 %	710 %
Temp. Rise at full load (by resistance method)			Efficiency				
at 1.0 S.F			80 deg. C				
Motor Location	<input type="checkbox"/> Indoor <input type="checkbox"/> Outdoor		50% Load		88.0 %		
Altitude	Less than 1,000 meter		75% Load		90.0 %		
Relative Humidity	Less than 80 %		100% Load		91.0 %		
Ambient Temp.	40 deg. C (Max.)		Power Factor(p.u)				
Duty Type	Continuous (S1)		50% Load		0.730		
Service Factor	1.15		75% Load		0.830		
Mounting	B35		100% Load		0.880		
Bearing	Type	Anti-Friction	Speed at Full Load				
	DE/N-DE	6309ZC3 / 6309ZC3	3550 r.p.m				
	Lubricant	Grease(Polyrex-EM)	Torque				
External Thrust	Not applicable		Full Load		21.8 lb.ft		
Coupling Method	<input checked="" type="checkbox"/> Direct <input type="checkbox"/> V-belt		Locked-rotor**		150 %		
Shaft Extension	Single		Breakdown**		250 %		
Terminal	Main	Cast Iron	Moment of Inertia (J)				
Box	Aux.	No	Load(Max.)		15.597 lb.ft2		
	Location	Refer to Outline Drawing	Motor		0.926 lb.ft2		
Application			Sound Pressure Level (No-load & mean value at 1m from motor)				
Area classification	Hazardous		77 dB(A)				
Type of Ex-Protection	Class I&II, Division 2		Vibration				
Applicable Standard	NEMA MG1, CSA C390		3.8 mm/sec (peak)				
ACCESSORIES			SUBMITTAL DRAWING				
			Outline Dimension Drawing		Motor Weight(Approx.)		
SPARE PARTS			B35		LM-T2254C4PLV23	255 lb.	
			REMARK				
SPARE PARTS			1. Premium efficiency according to NEMA MG1 2. Inverter Duty @ 1.0 Service Factor & F Temperature rise -. 10:1 VT (20:1 VT at 50% load) -. 10:1 CT -. CHP up to 1.5 times base speed, NEMA MG1 Part31 3. CSA Certification -. Class I, Division 2, Group A, B, C & D -. Class II, Division 2 Group E, F & G (Group E : up to 320Fr.) 4. Service Factor 1.15 and Temperature rise B are applicable under the condition of sine wave power. 5. Service Factor 1.25 is applicable to motors of 100HP or less with temperature rise F & Non-Hazardous.				
			Date	DSND	CHKD	CHKD	APPD
			2024-09-10	S.H. Lee	I.K. Kim	R.G. Kim	S.W. Kim

[Note] Others not mentioned in this data sheet shall be in accordance with maker standard.
 Above technical data are only design values and shall be guaranteed with tolerance of applicable standard.
 Inspection and performance test shall be done according to maker standard, if not mentioned.
 * In case of Inverter-Fed Motor, performance data is based on sine wave tests. It may be different from test data of Inverter combined motor.
 ** Data is based on rated voltage & frequency and is expressed as a percentage of full-load value.

1	2	3	4
REV	DATE	CONTENTS	REVD BY CHKD BY CHKD BY APPD BY

4.72

CROWN TRITON G2
Premium Efficiency AC 3 Phase Motor

15HP	2P	230/460V	Cat. No.	HES15-36-254TC						
Model	HLS254PR13		INS. Class	F	HD-F1	Amps	34.5/17.2			
Type	HLS	Duty	CONT	Code	H	Amb.	40°C	Hertz	60Hz	
Frame	254TC	Encl.	TEFC	S.F.	1.15	RPM	3550	NEMA Nom. Eff.	91%	
Bearing	Drive	6309ZC3		S.F.1.25 (When 100HP or less, Temp Rise F & Non-Hazardous)		3/4 Eff.	90%			
	Opp.	6309ZC3		S.F.1.00 (10:1 C.T., 20:1 V.T., NEMA-MG1 Part31)		NEMA Design	B Torque			
Usable at	50Hz 15HP 380V 23.23A 2935rpm S.F.: 1 Eff.: 90.2% Code: F									
	50Hz 15HP 400/415V 22.38/21.91A 2945/2945rpm S.F.: 1 Eff.: 90.2/90.2% Code: G/H									
CSA Certified for	Model	LATER		Type	PJP	Temp. Code	Frame	140~320FR	360~400FR	440FR
	CLASS I, Div. 2, Gr. A, B, C & D CLASS I, Zone 2, Gr. IIA, IIB, & IIC	CLASS II, Div. 2 Gr. E, F & G (Gr. E: Up to 320FR)		(sine wave)	Amb. 40°C	T3C (160°C)	T3B (165°C)	T3A (180°C)		
					Amb. 55°C	T3A (180°C)	T3A (180°C)	T3 (200°C)		
No.	-		Date	-		Weight	255 lb			

4M-136024
MARINE DUTY IEEE45

Made in Vietnam H4
Designed By HYUNDAI, Korea

2.36

APPD BY	S.Y.KIM	UNIT	INCH	SUBJECT	CSA Class I, Division2 Severe Duty (HES, 254-326)	DWG SIZE	A4 (1:1)
CHKD BY	I.K.KIM	SCALE	NONE				
CHKD BY	R.G.KIM	PROJEC'N	3rd Angle	NAMEPLATE DRAWING			
DSND BY	S.H.LEE	DATE	2024.06.07				
				REF. NO	4M-136024	Sheet No.	of
				DWG NO	NP-HES15-36-254TC	Revision No.	0

Type :	PJP
Full Load Torque :	21.8 lb.ft
Load moment of Inertia (J) :	15.597 lb.ft2
Motor moment of Inertia (J) :	0.926 lb.ft2

11kW 15HP	2 P	60 Hz
Speed at Full Load :		3550 RPM
Rated Voltage	575V	460V 230V
Full Load Current	13.8A	17.2A 34.5A

SPEED VS TORQUE & CURRENT CURVE

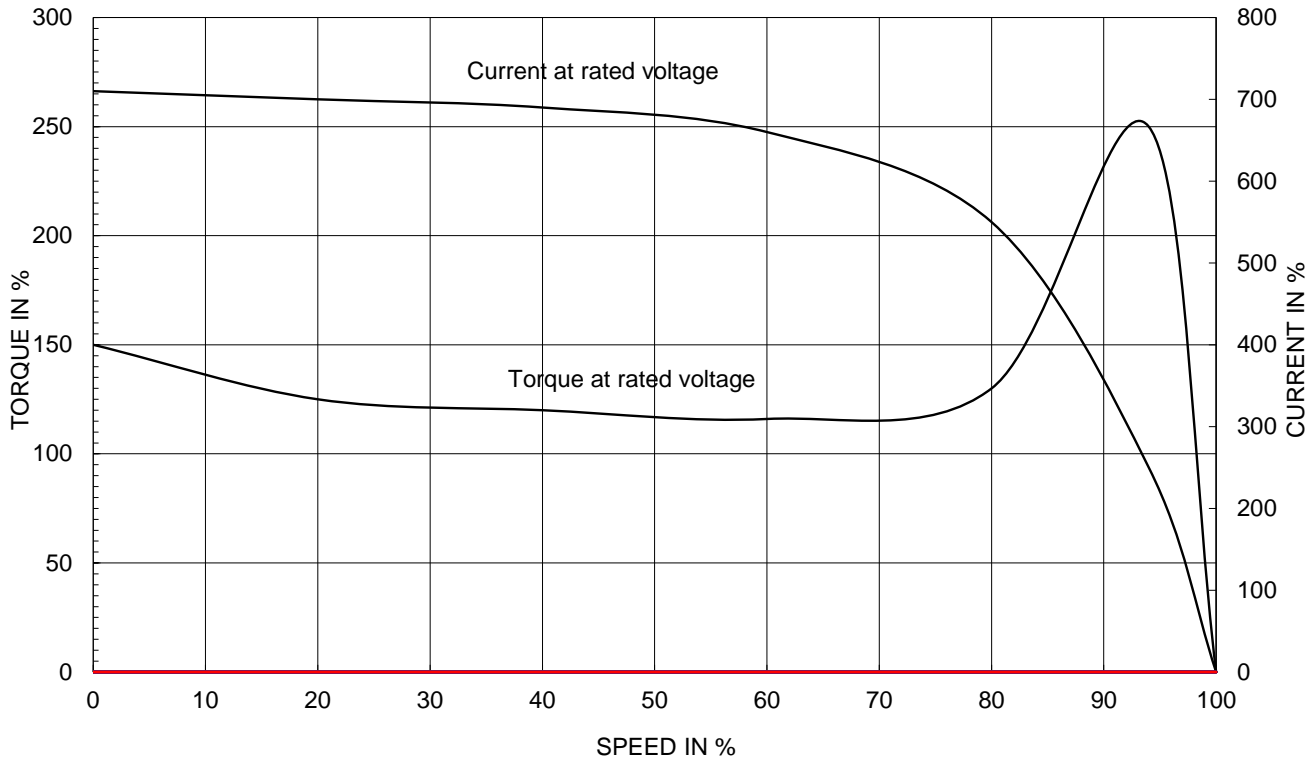

OUTPUT VS EFF., P.F & CURRENT CURVE

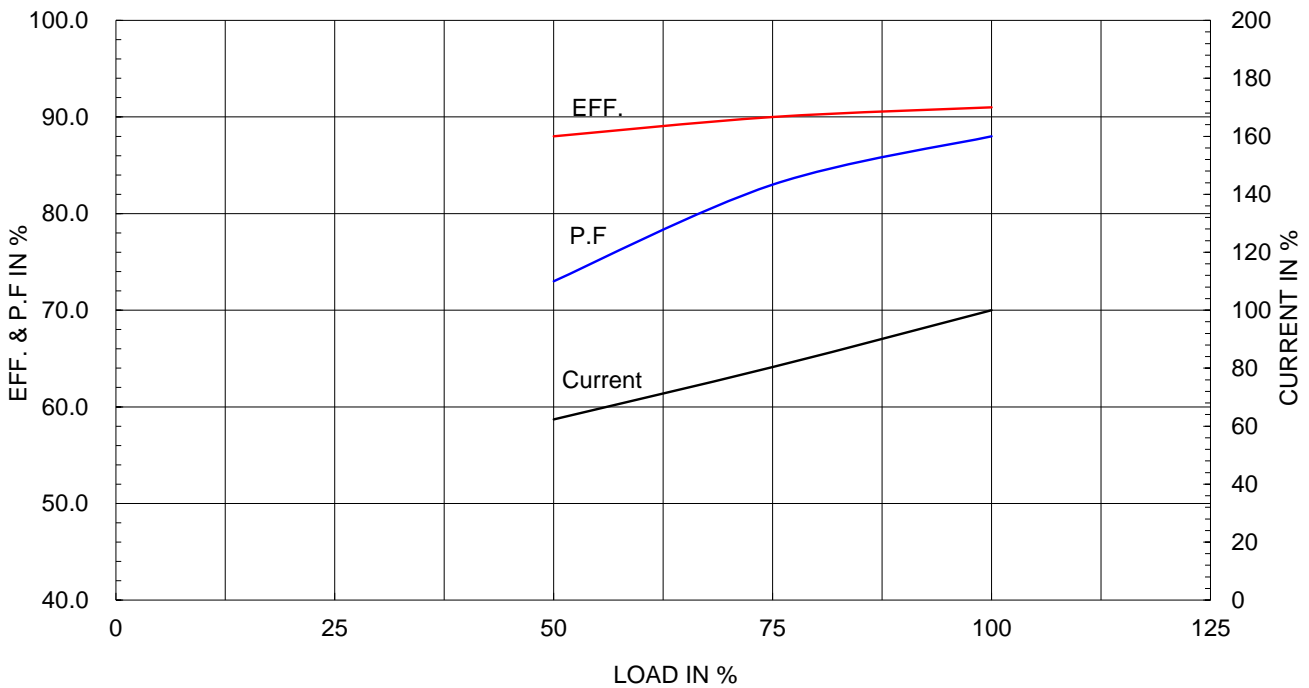

본 도면은 HD현대일렉트릭(주) 재산이며 허가없이 복사할 수 없음 (취급유의)

THIS DRAWING IS PROPRIETARY TO HYUNDAI ELECTRIC. NO PART OF THIS DRAWING MAYBE REPRODUCED WITHOUT THE PERMISSION OF HYUNDAI ELECTRIC.

▽	50S	REV	DATE	CONTENTS	REVD BY	CHKD BY	CHKD BY	APPD BY
▽▽	12.5S							
▽▽▽	3.2S							
▽▽▽▽	0.4S							

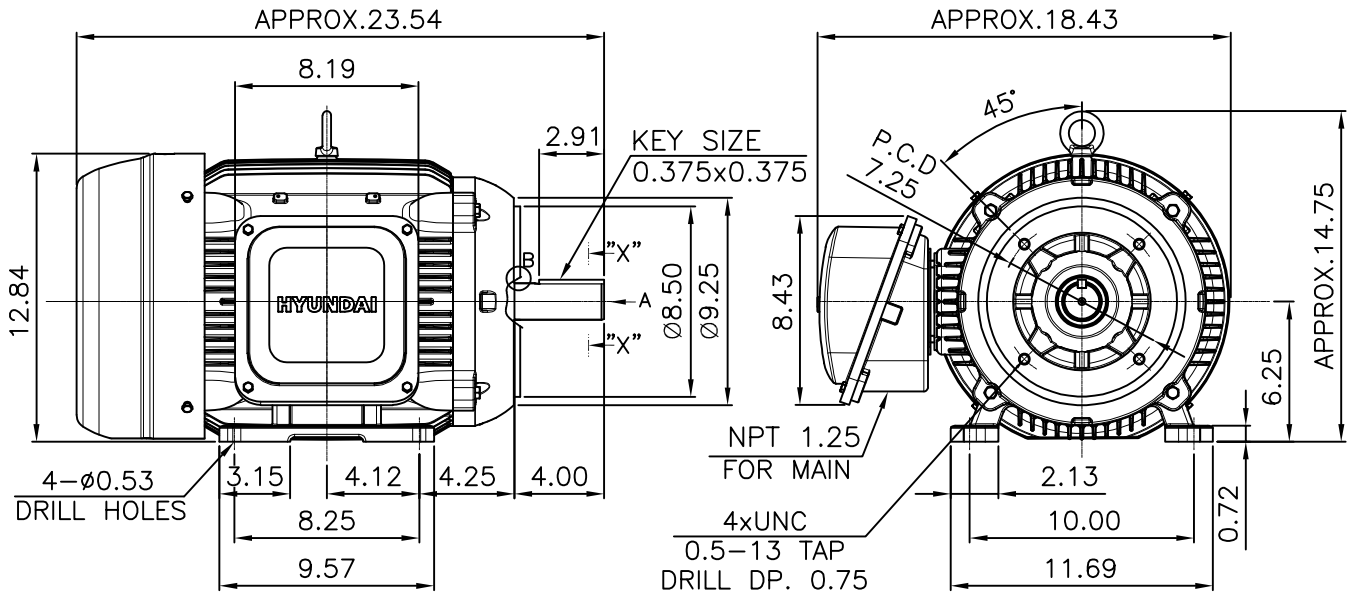

VIEW "A"

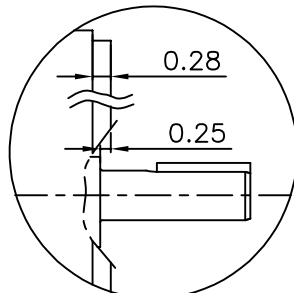

DETAIL - B

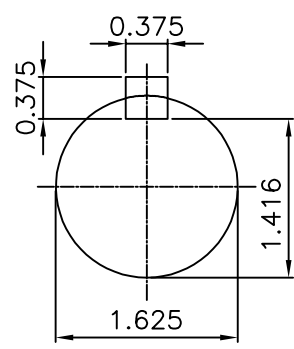

SECTION "X-X"
SCALE 5/9

NOTE

[TOLERANCE]

- CENTER HEIGHT : +0.00inch - 0.03inch
- SHAFT DIAMETER : +0.000inch - 0.001inch
- KEYWAY DEPTH : +0.000inch - 0.015inch

APPD BY	S.Y.KIM	UNIT	inch	SUBJECT	NEMA 254TC	DWG SIZE	A4 (1:9)
CHKD BY	R.G.KIM	SCALE	1/9	TITLE	OUTLINE	REF. NO	Sheet No. of
CHKD BY		PROJEC'N	3rd Angle				
DSND BY	주유람	DATE	2021-04-29				
				DWG NO	LM-T2254C4PLV23	Revision No. 0	



Cls. I&II, Div. 2 IEEE 841



▽	50S
▽▽	12.5S
▽▽▽	3.2S
▽▽▽▽	0.4S

REV	DATE	CONTENTS	REVD BY	CHKD BY	CHKD BY	APPD BY

일반가공공차		일반제관공차	
1-4	±0.1	6-30	±0.5
4-18	±0.2	30-120	±0.8
18-63	±0.3	120-315	±1.2
63-250	±0.5	315-1000	±2.0
250-	±0.8	1000-	±3.0

Q'TY	DESCRIPTION	MATERIAL	DIMENSION	WEIGHT	PART NO.	REMARK	NO.
APPD BY	S.Y.KIM	UNIT	inch(mm)	SUBJECT	FR. 250-280 (CAST IRON)	DWG SIZE	
CHKD BY		SCALE	1/2	TITLE	TERMINAL BOX ASS'Y		
CHKD BY	R.G.KIM	PROJEC'N	3rd Angle	DATE	2023-10-19		
DSND BY	배승희						
REF. NO		Sheet No.	of	DWG NO	3M-248458	Revision No.	0

