

Customer :
 Project Name :
 Project No. :
 Revision No. :

SPECIFICATION for INDUCTION MOTOR



| 0 | | For Bidding | | | |
|-----|------|-------------|-------------|------------|-------------|
| No. | DATE | DESCRIPTION | PREPARED BY | CHECKED BY | APPROVED BY |



AC INDUCTION MOTOR DATA SHEET

| | | | | |
|--------------|---------------|-------------|----------|----------|
| Catalog No. | HES15-12-284T | Item No. | Rev. No. | [] |
| Project Name | | Project No. | Quantity | sets |

| GENERAL SPECIFICATION | | | PERFORMANCE DATA | | | |
|--|--|--------------------------|--|----------------|-----------------------------|--------|
| Frame Size | 284T | | Rated Output | 11 kW | | 15 HP |
| Type | PJP | | Number of Poles | 6 | | |
| Enclosure(Protection) | Totally Enclosed | / IP55 | Rotor Type | Squirrel Cage | | |
| Method of Cooling | IC411(FC) | | Starting Method* | D.O.L | | |
| Rated Frequency | 60 Hz | | Rated Voltage | 575 V | 460 V | 230 V |
| Number of Phases | 3 | | Current | Full Load | 15.6 A | 19.6 A |
| Insulation Class | F | | | Locked-rotor** | 600 % | 600 % |
| Temp. Rise at full load (by resistance method) | | | Efficiency | | | |
| at 1.0 S.F | 80 deg. C | | 50% Load | | 88.7 % | |
| Motor Location | <input type="checkbox"/> Indoor <input type="checkbox"/> Outdoor | | 75% Load | | 90.7 % | |
| Altitude | Less than 1,000 meter | | 100% Load | | 91.7 % | |
| Relative Humidity | Less than 80 % | | Power Factor(p.u) | | | |
| Ambient Temp. | 40 deg. C (Max.) | | 50% Load | | 0.620 | |
| Duty Type | Continuous (S1) | | 75% Load | | 0.720 | |
| Service Factor | 1.15 | | 100% Load | | 0.770 | |
| Mounting | B3 | | Speed at Full Load | 1175 r.p.m | | |
| Bearing | Type | Anti-Friction | Torque | | | |
| | DE/N-DE | 6310ZC3 / 6310ZC3 | Full Load | | 66.0 lb.ft | |
| | Lubricant | Grease(Polyrex-EM) | Locked-rotor** | | 155 % | |
| External Thrust | Not applicable | | Breakdown** | | 240 % | |
| Coupling Method | <input checked="" type="checkbox"/> Direct <input type="checkbox"/> V-belt | | Moment of Inertia (J) | | | |
| Shaft Extension | Single | | Load(Max.) | | 242.105 lb.ft2 | |
| Terminal Box | Main | Cast Iron | Motor | | 4.984 lb.ft2 | |
| | Aux. | No | Sound Pressure Level (No-load & mean value at 1m from motor) | | | |
| | Location | Refer to Outline Drawing | | | 65 dB(A) | |
| Application | | | Vibration | | 3.8 mm/sec (peak) | |
| Area classification | Hazardous | | Permissible number of consecutive starts | | Cold 3 times Hot 2 times | |
| Type of Ex-Protection | Class I&II, Division 2 | | Paint | Munsell No. | 4.0PB5.4/5.5(VL-451) | |
| Applicable Standard | NEMA MG1, CSA C390 | | | | | |

| ACCESSORIES |
|-------------|
| |

| SUBMITTAL DRAWING | | | |
|---------------------------|-----------------|-----------------------|--|
| Outline Dimension Drawing | | Motor Weight(Approx.) | |
| B3 | LM-T2284B3PLV23 | 360 lb. | |
| | | | |
| | | | |

| SPARE PARTS |
|-------------|
| |

| REMARK | | | | |
|---|----------|----------|----------|----------|
| 1. Premium efficiency according to NEMA MG1 2. Inverter Duty @ 1.0 Service Factor & F Temperature rise -. 10:1 VT (20:1 VT at 50% load) -. 10:1 CT -. CHP up to 1.5 times base speed, NEMA MG1 Part31 3. CSA Certification -. Class I, Division 2, Group A, B, C & D -. Class II, Division 2 Group E, F & G (Group E : up to 320Fr.) 4. Service Factor 1.15 and Temperature rise B are applicable under the condition of sine wave power. 5. Service Factor 1.25 is applicable to motors of 100HP or less with temperature rise F & Non-Hazardous. | | | | |
| Date | DSND | CHKD | CHKD | APPD |
| 2024-09-10 | S.H. Lee | I.K. Kim | R.G. Kim | S.W. Kim |

[Note] Others not mentioned in this data sheet shall be in accordance with maker standard.
 Above technical data are only design values and shall be guaranteed with tolerance of applicable standard.
 Inspection and performance test shall be done according to maker standard, if not mentioned.
 * In case of Inverter-Fed Motor, performance data is based on sine wave tests. It may be different from test data of Inverter combined motor.
 ** Data is based on rated voltage & frequency and is expressed as a percentage of full-load value.

| | | | |
|-----|------|----------|---------------------------------|
| 1 | 2 | 3 | 4 |
| REV | DATE | CONTENTS | REVD BY CHKD BY CHKD BY APPD BY |
| | | | |
| | | | |

4.72

CROWN TRITON G2
Premium Efficiency AC 3 Phase Motor



| | | | | | | | | | | |
|-------------------|--|---|------------|--|-----------|-------------|-------------|----------------|-----------|-------|
| 15HP | 6P | 230/460V | Cat. No. | HES15-12-284T | | | | | | |
| Model | HLS284SR33 | | INS. Class | F | HD-F1 | Amps | 39.1/19.6 | | | |
| Type | HLS | Duty | CONT | Code | G | Amb. | 40°C | Hertz | 60Hz | |
| Frame | 284T | Encl. | TEFC | S.F. | 1.15 | RPM | 1175 | NEMA Nom. Eff. | 91.7% | |
| Bearing | Drive | 6310ZC3 | | S.F.1.25 (When 100HP or less, Temp Rise F & Non-Hazardous) | | 3/4 Eff. | 90.7% | | | |
| | Opp. | 6310ZC3 | | S.F.1.00 (10:1 C.T., 20:1 V.T., NEMA-MG1 Part31) | | NEMA Design | B | | | |
| Usable at | 50Hz 15HP 380V 25.53A 970rpm S.F.: 1.15 Eff.: 90.2% Code: G | | | | | | | | | |
| | 50Hz 15HP 400/415V 25.41/25.72A 975/975rpm S.F.: 1.15 Eff.: 90.2/90.2% Code: H/J | | | | | | | | | |
| CSA Certified for | Model | LATER | | Type | PJP | Temp. Code | Frame | 140~320FR | 360~400FR | 440FR |
| | CLASS I, Div. 2, Gr. A, B, C & D CLASS I, Zone 2, Gr. IIA, IIB, & IIC | CLASS II, Div. 2 Gr. E, F & G (Gr. E: Up to 320FR) | | (sine wave) | Amb. 40°C | T3C (160°C) | T3B (165°C) | T3A (180°C) | | |
| | | | | | Amb. 55°C | T3A (180°C) | T3A (180°C) | T3 (200°C) | | |
| No. | - | | Date | - | | Weight | 360 lb | | | |

4M-136024
MARINE DUTY IEEE45

Made in Vietnam H4
Designed By HYUNDAI, Korea



2.36

| | | | | | | | |
|---------|---------|----------|------------|----------------------------|---|--------------|------------|
| APPD BY | S.Y.KIM | UNIT | INCH | SUBJECT | CSA Class I, Division2 Severe Duty (HES, 254-326) | DWG SIZE | A4 (1:1) |
| CHKD BY | I.K.KIM | SCALE | NONE | | | | |
| CHKD BY | R.G.KIM | PROJEC'N | 3rd Angle | TITLE NAMEPLATE DRAWING | | | |
| DSND BY | S.H.LEE | DATE | 2024.06.07 | | | | |
| | | | | REF. NO | 4M-136024 | Sheet No. | of |
| | | | | DWG NO | NP-HES15-12-284T | Revision No. | 0 |



PERFORMANCE CURVE

CURVE NO.

PC-HES15-12-284T

| | |
|-------------------------------|----------------|
| Type : | PJP |
| Full Load Torque : | 66.0 lb.ft |
| Load moment of Inertia (J) : | 242.105 lb.ft2 |
| Motor moment of Inertia (J) : | 4.984 lb.ft2 |

| | | |
|----------------------|-------|-------------|
| 11kW 15HP | 6 P | 60 Hz |
| Speed at Full Load : | | 1175 RPM |
| Rated Voltage | 575V | 460V 230V |
| Full Load Current | 15.6A | 19.6A 39.1A |

SPEED VS TORQUE & CURRENT CURVE

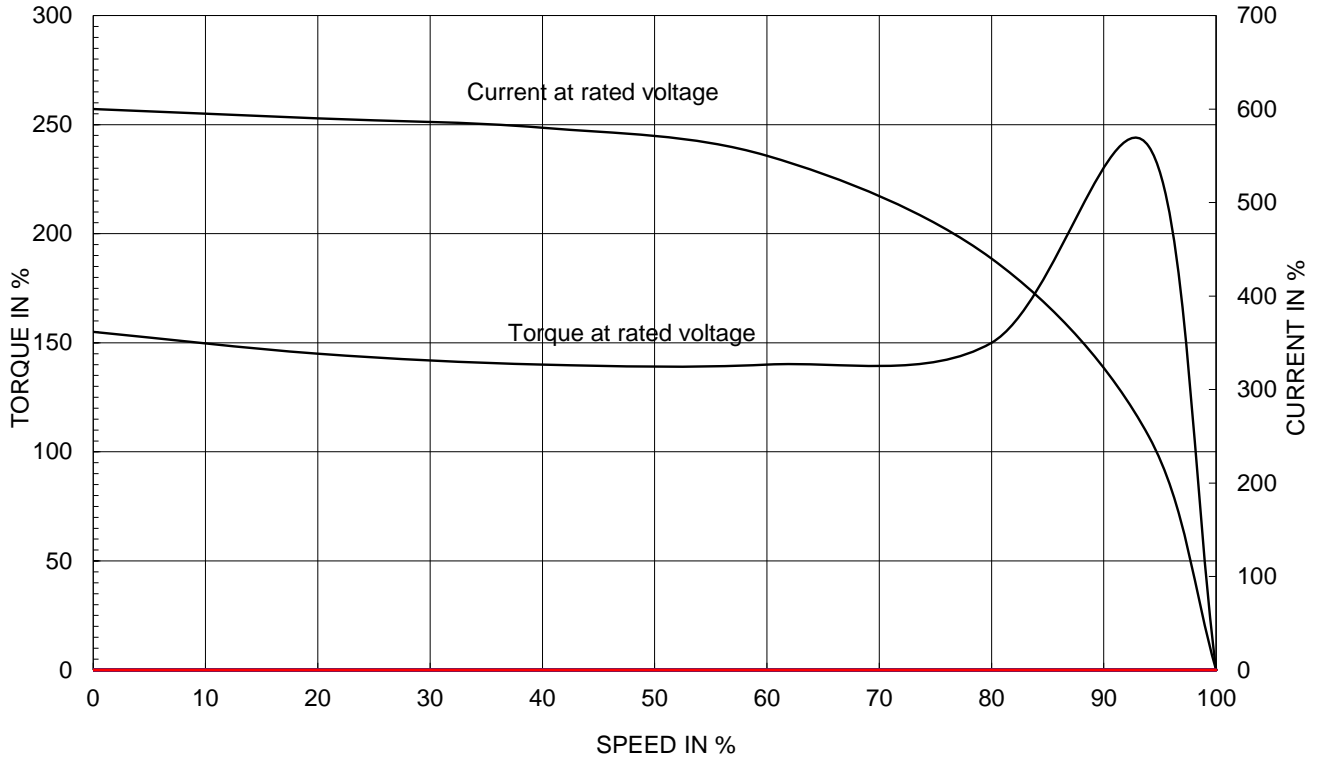

OUTPUT VS EFF., P.F & CURRENT CURVE

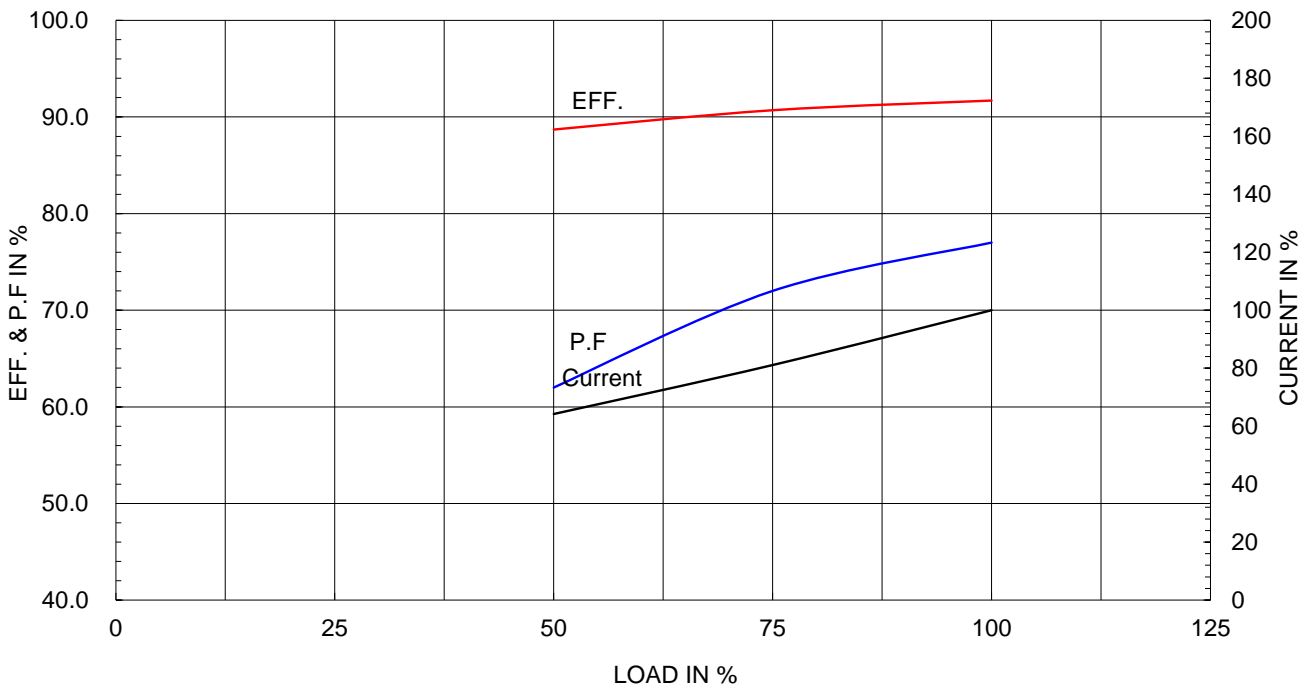

본 도면은 HD현대일렉트릭(주) 재산이며 허가없이 복사할 수 없음 (취급유의)

THIS DRAWING IS PROPRIETARY TO HYUNDAI ELECTRIC. NO PART OF THIS DRAWING MAYBE REPRODUCED WITHOUT THE PERMISSION OF HYUNDAI ELECTRIC.

| | | | | | | | | |
|------|-------|-----|------|----------|---------|---------|---------|---------|
| ▽ | 50S | REV | DATE | CONTENTS | REVD BY | CHKD BY | CHKD BY | APPD BY |
| ▽▽ | 12.5S | | | | | | | |
| ▽▽▽ | 3.2S | | | | | | | |
| ▽▽▽▽ | 0.4S | | | | | | | |

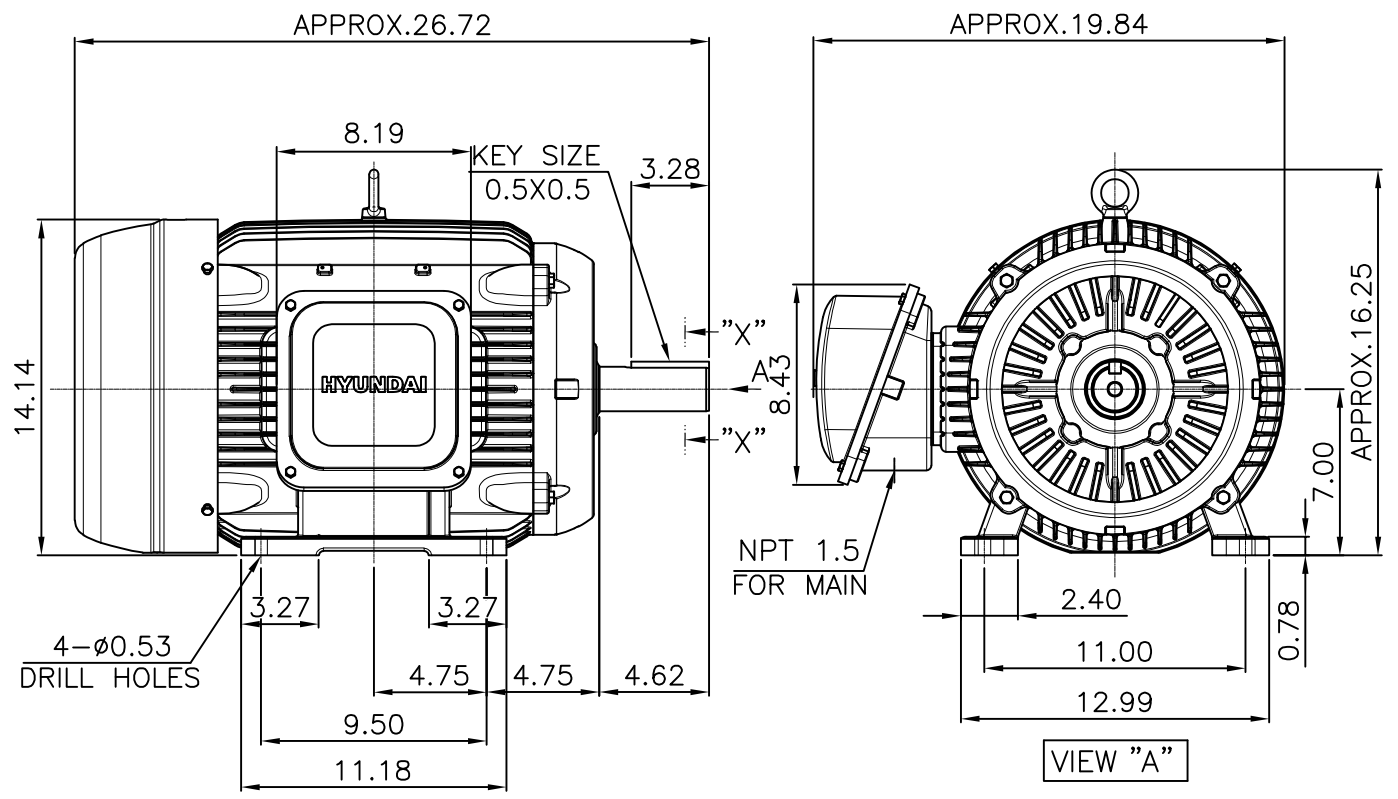

NOTE
[TOLERANCE]

- CENTER HEIGHT : +0.00inch - 0.03inch
- SHAFT DIAMETER : +0.000inch - 0.001inch
- KEYWAY DEPTH : +0.000inch - 0.015inch

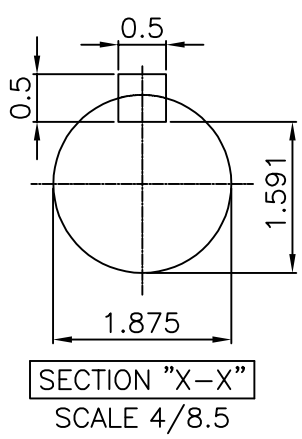

| | | | | | | | |
|---------|---------|----------|------------|---------|-----------------|--------------|--------------|
| APPD BY | S.Y.KIM | UNIT | inch | SUBJECT | NEMA 284T | DWG SIZE | A4 (18.5) |
| CHKD BY | R.G.KIM | SCALE | 1/8.5 | TITLE | OUTLINE | REF. NO | Sheet No. of |
| CHKD BY | | PROJEC'N | 3rd Angle | | | | |
| DSND BY | 주유람 | DATE | 2021-04-28 | | | | |
| | | | | DWG NO | LM-T2284B3PLV23 | Revision No. | 0 |



Cls. I&II, Div. 2 IEEE 841



SEC. "A" - "A"

| | |
|------|-------|
| ▽ | 50S |
| ▽▽ | 12.5S |
| ▽▽▽ | 3.2S |
| ▽▽▽▽ | 0.4S |

| REV | DATE | CONTENTS | REVD BY | CHKD BY | CHKD BY | APPD BY |
|-----|------|----------|---------|---------|---------|---------|
| | | | | | | |

| 일반가공공차 | | 일반제관공차 | |
|--------|------|----------|------|
| 1-4 | ±0.1 | 6-30 | ±0.5 |
| 4-18 | ±0.2 | 30-120 | ±0.8 |
| 18-63 | ±0.3 | 120-315 | ±1.2 |
| 63-250 | ±0.5 | 315-1000 | ±2.0 |
| 250- | ±0.8 | 1000- | ±3.0 |

| Q'TY | DESCRIPTION | MATERIAL | DIMENSION | WEIGHT | PART NO. | REMARK | NO. |
|---------|-------------|-----------|-----------|---------|-------------------------|--------------|-----|
| APPD BY | S.Y.KIM | UNIT | inch(mm) | SUBJECT | FR. 250-280 (CAST IRON) | DWG SIZE | |
| CHKD BY | | SCALE | 1/2 | TITLE | TERMINAL BOX ASS'Y | | |
| CHKD BY | R.G.KIM | PROJEC'N | 3rd Angle | DATE | 2023-10-19 | | |
| DSND BY | 배승희 | | | | | | |
| REF. NO | | Sheet No. | of | DWG NO | 3M-248458 | Revision No. | 0 |

