

Customer :
 Project Name :
 Project No. :
 Revision No. :

SPECIFICATION for INDUCTION MOTOR



0		For Bidding			
No.	DATE	DESCRIPTION	PREPARED BY	CHECKED BY	APPROVED BY



AC INDUCTION MOTOR DATA SHEET

Catalog No.	HES10-36-215TC	Item No.		Rev. No.	[]
Project Name		Project No.		Quantity	sets

GENERAL SPECIFICATION			PERFORMANCE DATA			
Frame Size	215TC		Rated Output	7.5 kW		10 HP
Type	PJP		Number of Poles	2		
Enclosure(Protection)	Totally Enclosed	/	IP55	Rotor Type	Squirrel Cage	
Method of Cooling	IC411(FC)		Starting Method*	D.O.L		
Rated Frequency	60 Hz		Rated Voltage	575 V	460 V	230 V
Number of Phases	3		Current	Full Load	9.71 A	12.13 A
Insulation Class	F			Locked-rotor**	680 %	680 %
Temp. Rise at full load (by resistance method)			Efficiency			
at 1.0 S.F	80 deg. C		50% Load		87.2 %	
Motor Location	<input type="checkbox"/> Indoor <input type="checkbox"/> Outdoor		75% Load		89.2 %	
Altitude	Less than 1,000 meter		100% Load		90.2 %	
Relative Humidity	Less than 80 %		Power Factor(p.u)			
Ambient Temp.	40 deg. C (Max.)		50% Load		0.710	
Duty Type	Continuous (S1)		75% Load		0.810	
Service Factor	1.15		100% Load		0.860	
Mounting	B35		Speed at Full Load	3525 r.p.m		
Bearing	Type	Anti-Friction		Torque		
	DE/N-DE	6208ZZC3 / 6208ZZC3		Full Load	15.0 lb.ft	
	Lubricant	Grease(Polyrex-EM)		Locked-rotor**	160 %	
External Thrust	Not applicable		Breakdown**	260 %		
Coupling Method	<input checked="" type="checkbox"/> Direct <input type="checkbox"/> V-belt		Moment of Inertia (J)			
Shaft Extension	Single		Load(Max.)		11.159 lb.ft2	
Terminal Box	Main	Cast Iron		Motor		0.451 lb.ft2
	Aux.	No		Sound Pressure Level (No-load & mean value at 1m from motor)		
	Location	Refer to Outline Drawing		73 dB(A)		
Application			Vibration			
Area classification	Hazardous		3.8 mm/sec (peak)			
Type of Ex-Protection	Class I&II, Division 2		Permissible number of consecutive starts	Cold	3 times	
Applicable Standard	NEMA MG1, CSA C390		Hot	2 times		
			Paint	Munsell No.	4.0PB5.4/5.5(VL-451)	

ACCESSORIES

SUBMITTAL DRAWING			
Outline Dimension Drawing		Motor Weight(Approx.)	
B35	LM-T2215C4PLV23	190 lb.	

SPARE PARTS

REMARK				
1. Premium efficiency according to NEMA MG1 2. Inverter Duty @ 1.0 Service Factor & F Temperature rise -. 10:1 VT (20:1 VT at 50% load) -. 10:1 CT -. CHP up to 1.5 times base speed, NEMA MG1 Part31 3. CSA Certification -. Class I, Division 2, Group A, B, C & D -. Class II, Division 2 Group E, F & G (Group E : up to 320Fr.) 4. Service Factor 1.15 and Temperature rise B are applicable under the condition of sine wave power. 5. Service Factor 1.25 is applicable to motors of 100HP or less with temperature rise F & Non-Hazardous.				
Date	DSND	CHKD	CHKD	APPD
2024-09-10	S.H. Lee	I.K. Kim	R.G. Kim	S.W. Kim

[Note] Others not mentioned in this data sheet shall be in accordance with maker standard.
 Above technical data are only design values and shall be guaranteed with tolerance of applicable standard.
 Inspection and performance test shall be done according to maker standard, if not mentioned.
 * In case of Inverter-Fed Motor, performance data is based on sine wave tests. It may be different from test data of Inverter combined motor.
 ** Data is based on rated voltage & frequency and is expressed as a percentage of full-load value.

	1	2	3	4			
	REV	DATE	CONTENTS	REVD BY	CHKD BY	CHKD BY	APPD BY

3.94

1.57

CROWN TRITON G2 Premium Efficiency
AC 3 Phase Motor

Cat. No. HES10-36-215TC

10HP	2P	230/460V	Amps	24.27/12.1	Type	HLS	Amb.	40°C	
Frame	215TC	Duty	CONT	Encl.	TEFC	Model	HLS215PR135	NEMA Nom. Eff.	90.2%
RPM	3525	Hertz	60Hz	S.F.	1.15	INS Class	F HD-F1	3/4 Eff.	89.2%
Bearing	Drive	6208ZCC3	S.F.1.25 (When 100HP or less, Temp Rise F & Non-Hazardous)				NEMA Design	B	
	Opp.	6208ZCC3	S.F.1.00 (10:1 C.T., 20:1 V.T., NEMA-MG1 Part31)				Code	H	
Usable at	50Hz 10HP 380V 16.31A 2905rpm S.F.: 1 Eff.: 89.5% Code: G								
	50Hz 10HP 400/415V 15.75/15.45A 2915/2925rpm S.F.: 1 Eff.: 89.5/89.5% Code: H/H								
CSA Certified for	Model	LATER			Type	PJP	Temp. Code	Frame	140-320FR
	CLASS I, Div. 2, Gr. A, B, C & D		CLASS II, Div. 2, Gr. E, F & G (Gr. E: up to 320FR)			(Sine Wave)	Amb.40°C	T3C (160°C)	
	CLASS I, Zone 2, Gr. IIA, IIB & IIC						Amb.55°C	T3A (180°C)	
No.	-		Date	-		Weight	190 lb		

CC038A

4M-136021
MARINE DUTY IEEE45

Made in Vietnam H4
Designed By HYUNDAI, Korea



PERFORMANCE CURVE

CURVE NO.
PC-HES10-36-215TC

Type :	PJP	7.5kW 10HP	2 P	60 Hz
Full Load Torque :	15.0 lb.ft	Speed at Full Load : 3525 RPM		
Load moment of Inertia (J) :	11.159 lb.ft2	Rated Voltage	575V	460V 230V
Motor moment of Inertia (J) :	0.451 lb.ft2	Full Load Current	9.7A	12.1A 24.3A

SPEED VS TORQUE & CURRENT CURVE

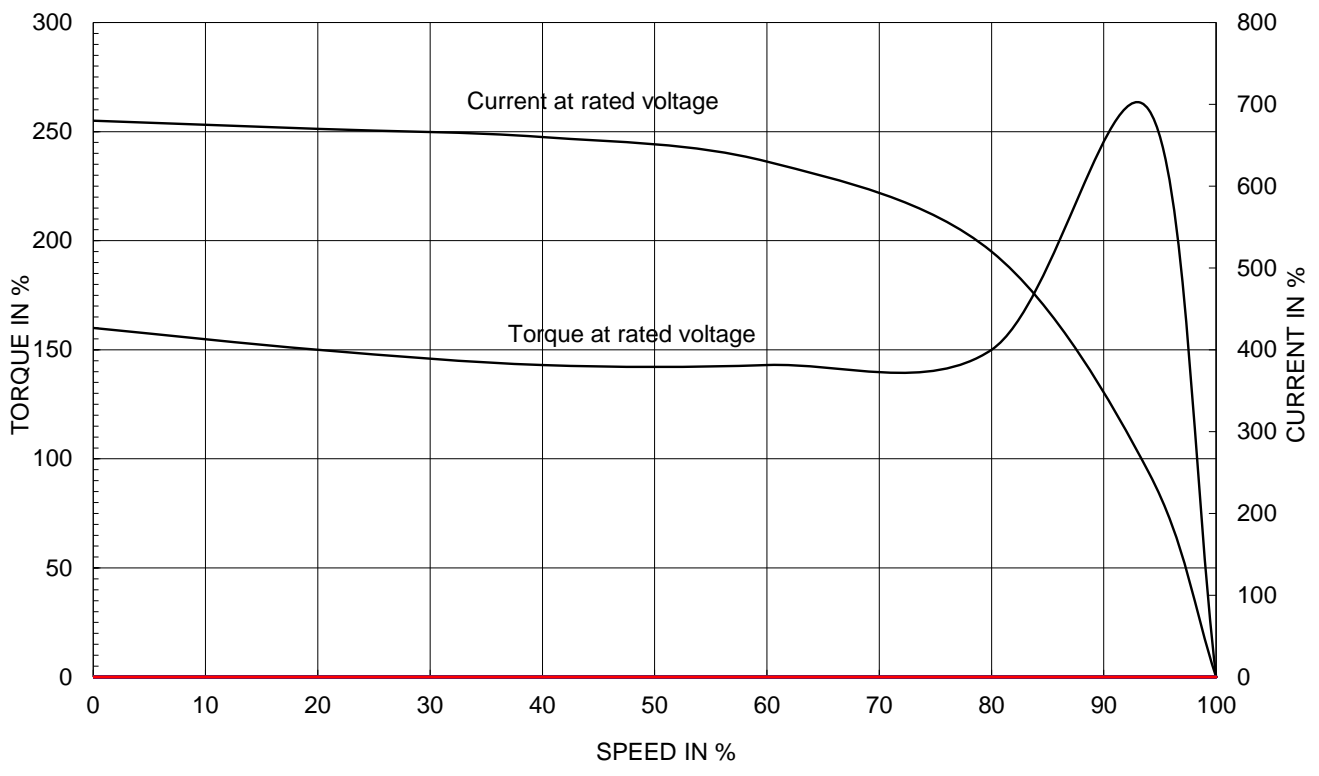

OUTPUT VS EFF., P.F & CURRENT CURVE

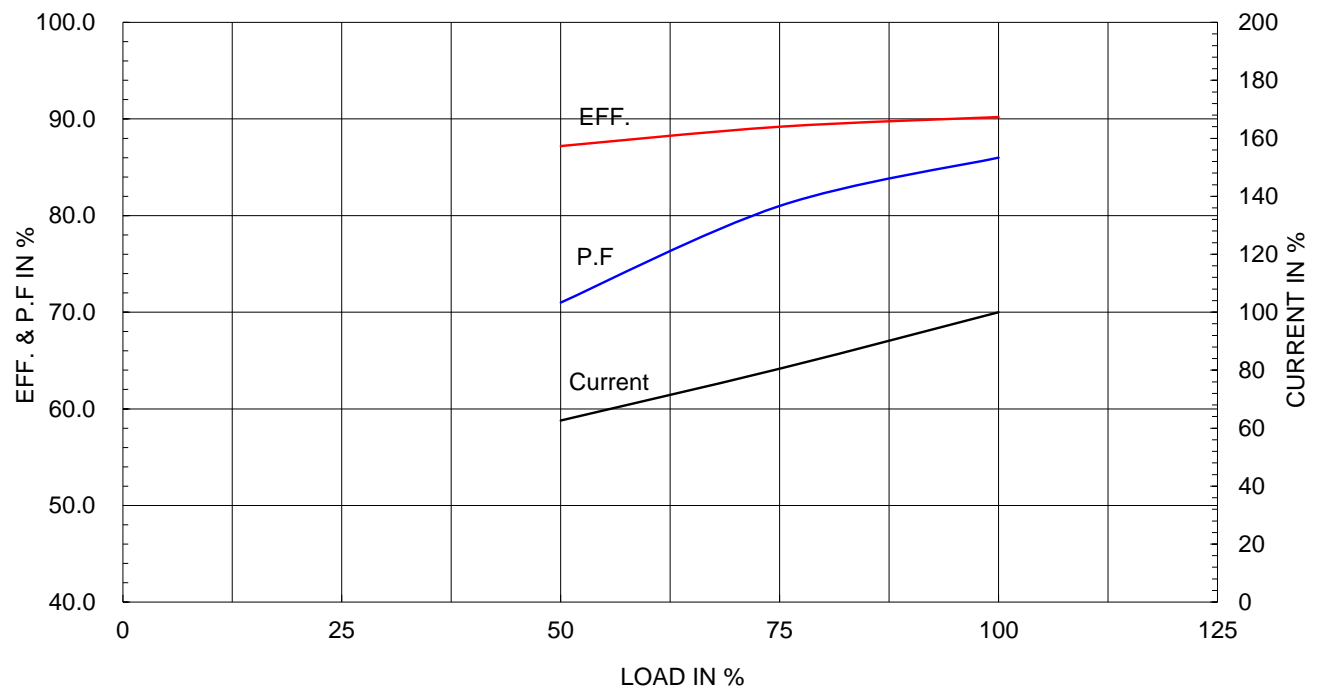

본 도면은 HD현대일렉트릭(주) 재산이며 허가없이 복사할 수 없음 (취급유의)

THIS DRAWING IS PROPRIETARY TO HYUNDAI ELECTRIC. NO PART OF THIS DRAWING MAYBE REPRODUCED WITHOUT THE PERMISSION OF HYUNDAI ELECTRIC.

▽	50S	REV	DATE	CONTENTS	REVD BY	CHKD BY	CHKD BY	APPD BY
▽▽	12.5S							
▽▽▽	3.2S							
▽▽▽▽	0.4S							

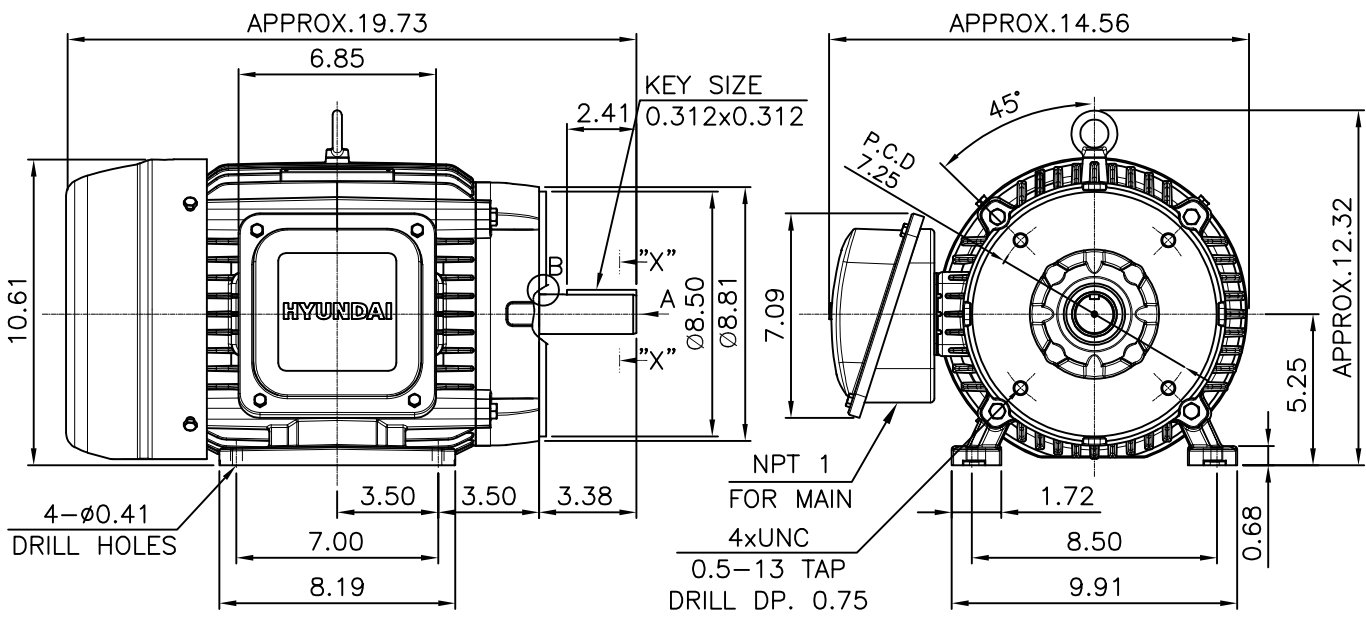

VIEW "A"

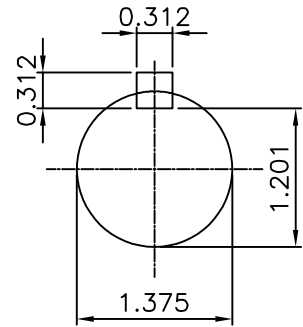
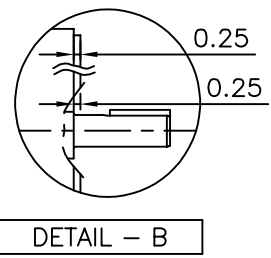

SECTION "X-X"
SCALE 4/7

NOTE

[TOLERANCE]

1. CENTER HEIGHT : +0.00inch - 0.03inch
2. SHAFT DIAMETER : +0.000inch - 0.0005inch
3. KEYWAY DEPTH : +0.000inch - 0.015inch

APPD BY	S.Y.KIM	UNIT	inch	SUBJECT	NEMA 215TC	DWG SIZE	A4 (1:7)
CHKD BY	R.G.KIM	SCALE	1/7	TITLE	OUTLINE	REF. NO	Sheet No. of
CHKD BY		PROJEC'N	3rd Angle				
DSND BY	주유림	DATE	2021-04-29				
				DWG NO	LM-T2215C4PLV23	Revision No.	0

**Cls. I&II, Div. 2
IEEE 841**



▽	50S
▽▽	12.5S
▽▽▽	3.2S
▽▽▽▽	0.4S

REV	DATE	CONTENTS	REVD BY	CHKD BY	CHKD BY	APPD BY

일반기공공차		일반재관공차	
1-4	±0.1	6-30	±0.5
4-18	±0.2	30-120	±0.8
18-63	±0.3	120-315	±1.2
63-250	±0.5	315-1000	±2.0
250-	±0.8	1000-	±3.0

Q'TY	DESCRIPTION	MATERIAL	DIMENSION	WEIGHT	PART NO.	REMARK	NO.
APPD BY	S.Y.KIM	UNIT	inch(mm)	SUBJECT	FR. 210 (CAST IRON)	DWG SIZE	
CHKD BY		SCALE	1/1.5	TITLE	TERMINAL BOX ASS'Y		
CHKD BY	R.G.KIM	PROJEC'N	3rd Angle	DATE	2023-10-19		
DSND BY	배승희						
REF. NO		Sheet No.	of				
DWG NO	3M-248457	Revision No.	0				

