

Customer :
 Project Name :
 Project No. :
 Revision No. :

SPECIFICATION for INDUCTION MOTOR



0		For Bidding			
No.	DATE	DESCRIPTION	PREPARED BY	CHECKED BY	APPROVED BY



AC INDUCTION MOTOR DATA SHEET

Catalog No.	HES1.5-36-143TCRD	Item No.	Rev. No.	[]
Project Name		Project No.	Quantity	sets

GENERAL SPECIFICATION			PERFORMANCE DATA			
Frame Size	143TC		Rated Output	1.1 kW 1.5 HP		
Type	PJP		Number of Poles	2		
Enclosure(Protection)	Totally Enclosed	/ IP55	Rotor Type	Squirrel Cage		
Method of Cooling	IC411(FC)		Starting Method*	D.O.L		
Rated Frequency	60 Hz		Rated Voltage	575 V	460 V	230 V
Number of Phases	3		Current	Full Load	1.57 A	1.96 A 3.91 A
Insulation Class	F			Locked-rotor**	1000 %	1,000 % 1,000 %
Temp. Rise at full load (by resistance method)			Efficiency			
at 1.0 S.F	80 deg. C		50% Load 81.0 %			
Motor Location	<input type="checkbox"/> Indoor <input type="checkbox"/> Outdoor		75% Load 83.0 %			
Altitude	Less than 1,000 meter		100% Load 84.0 %			
Relative Humidity	Less than 80 %		Power Factor(p.u)			
Ambient Temp.	40 deg. C (Max.)		50% Load 0.690			
Duty Type	Continuous (S1)		75% Load 0.790			
Service Factor	1.15		100% Load 0.840			
Mounting	B5		Speed at Full Load	3485 r.p.m		
Bearing	Type	Anti-Friction	Torque			
	DE/N-DE	6205ZZC3 / 6204ZZC3	Full Load 2.2 lb.ft			
	Lubricant	Grease(Polyrex-EM)	Locked-rotor** 185 %			
External Thrust	Not applicable		Breakdown** 260 %			
Coupling Method	<input checked="" type="checkbox"/> Direct <input type="checkbox"/> V-belt		Moment of Inertia (J)			
Shaft Extension	Single		Load(Max.) 2.119 lb.ft2			
Terminal Box	Main	Cast Iron	Motor 0.033 lb.ft2			
	Aux.	No	Sound Pressure Level (No-load & mean value at 1m from motor)			
Location	Refer to Outline Drawing		69 dB(A)			
Application			Vibration 3.8 mm/sec (peak)			
Area classification	Hazardous		Permissible number of consecutive starts			
Type of Ex-Protection	Class I&II, Division 2		Cold 3 times			
Applicable Standard	NEMA MG1, CSA C390		Hot 2 times			
	Paint	Munsell No.	4.0PB5.4/5.5(VL-451)			

ACCESSORIES

SUBMITTAL DRAWING			
Outline Dimension Drawing		Motor Weight(Approx.)	
B5	LM-T2143C5PLV23	60 lb.	

SPARE PARTS

REMARK				
1. Premium efficiency according to NEMA MG1 2. Inverter Duty @ 1.0 Service Factor & F Temperature rise -. 10:1 VT (20:1 VT at 50% load) -. 10:1 CT -. CHP up to 1.5 times base speed, NEMA MG1 Part31 3. CSA Certification -. Class I, Division 2, Group A, B, C & D -. Class II, Division 2 Group E, F & G (Group E : up to 320Fr.) 4. Service Factor 1.15 and Temperature rise B are applicable under the condition of sine wave power. 5. Service Factor 1.25 is applicable to motors of 100HP or less with temperature rise F & Non-Hazardous.				
Date	DSND	CHKD	CHKD	APPD
2024-09-10	S.H. Lee	I.K. Kim	R.G. Kim	S.W. Kim

[Note] Others not mentioned in this data sheet shall be in accordance with maker standard.
 Above technical data are only design values and shall be guaranteed with tolerance of applicable standard.
 Inspection and performance test shall be done according to maker standard, if not mentioned.
 * In case of Inverter-Fed Motor, performance data is based on sine wave tests. It may be different from test data of Inverter combined motor.
 ** Data is based on rated voltage & frequency and is expressed as a percentage of full-load value.

1	2	3	4
REV	DATE	CONTENTS	REVD BY CHKD BY CHKD BY APPD BY

3.94

CROWN TRITON G2 Premium Efficiency AC 3 Phase Motor Cat. No. HES1.5-36-143TRCD

1.5HP	2P	230/460V	Amps	3.91/1.96	Type	HLS	Amb.	40°C	
Frame	143TC	Duty	CONT	Encl.	TEFC	Model	HLS143PL135	NEMA Nom. Eff.	84%
RPM	3485	Hertz	60Hz	S.F.	1.15	INS Class	F HD-F1	3/4 Eff.	83%
Bearing	Drive	6205ZZC3	S.F.1.25 (When 100HP or less, Temp Rise F & Non-Hazardous)				NEMA Design	B	
	Opp.	6204ZZC3	S.F.1.00 (10:1 C.T., 20:1 V.T., NEMA-MG1 Part31)				Code	L	
Usable at	50Hz 1.5HP 380V 2.55A 2845rpm S.F.: 1.15 Eff.: 81.2% Code: H								
	50Hz 1.5HP 400/415V 2.41/2.36A 2865/2875rpm S.F.: 1.15 Eff.: 82.5/82.5% Code: J/K								
CSA Certified for	Model	LATER	Type	PJP	Temp. Code	Frame	140-320FR		
	CLASS I, Div. 2, Gr. A, B, C & D CLASS I, Zone 2, Gr. IIA, IIB & IIC		CLASS II, Div. 2, Gr. E, F & G (Gr. E : up to 320FR)		(Sine Wave)	Amb.40°C T3C (160°C) Amb.55°C T3A (180°C)			
No.	-		Date	-		Weight		60 lb	

4M-136021 Made in Vietnam H4 **HD HYUNDAI ELECTRIC**
MARINE DUTY IEEE45 Designed By HYUNDAI, Korea

1.57

APPD BY	S.Y.KIM	UNIT	INCH	SUBJECT	CSA Class I, Division2 Severe Duty (HES, 143-215)	DWG SIZE
CHKD BY	I.K.KIM	SCALE	NONE			A4 (1:1)
CHKD BY	R.G.KIM	PROJEC'N	3rd Angle	TITLE NAMEPLATE DRAWING		
DSND BY	S.H.LEE	DATE	2024.06.07			
				REF. NO	4M-136021	Sheet No. of
				DWG NO	NP-HES1.5-36-143TRCD	Revision No. 0

Type :	PJP
Full Load Torque :	2.2 lb.ft
Load moment of Inertia (J) :	2.119 lb.ft2
Motor moment of Inertia (J) :	0.033 lb.ft2

1.1kW	1.5HP	2 P	60 Hz
Speed at Full Load :			3485 RPM
Rated Voltage	575V	460V	230V
Full Load Current	1.6A	2.0A	3.9A

SPEED VS TORQUE & CURRENT CURVE

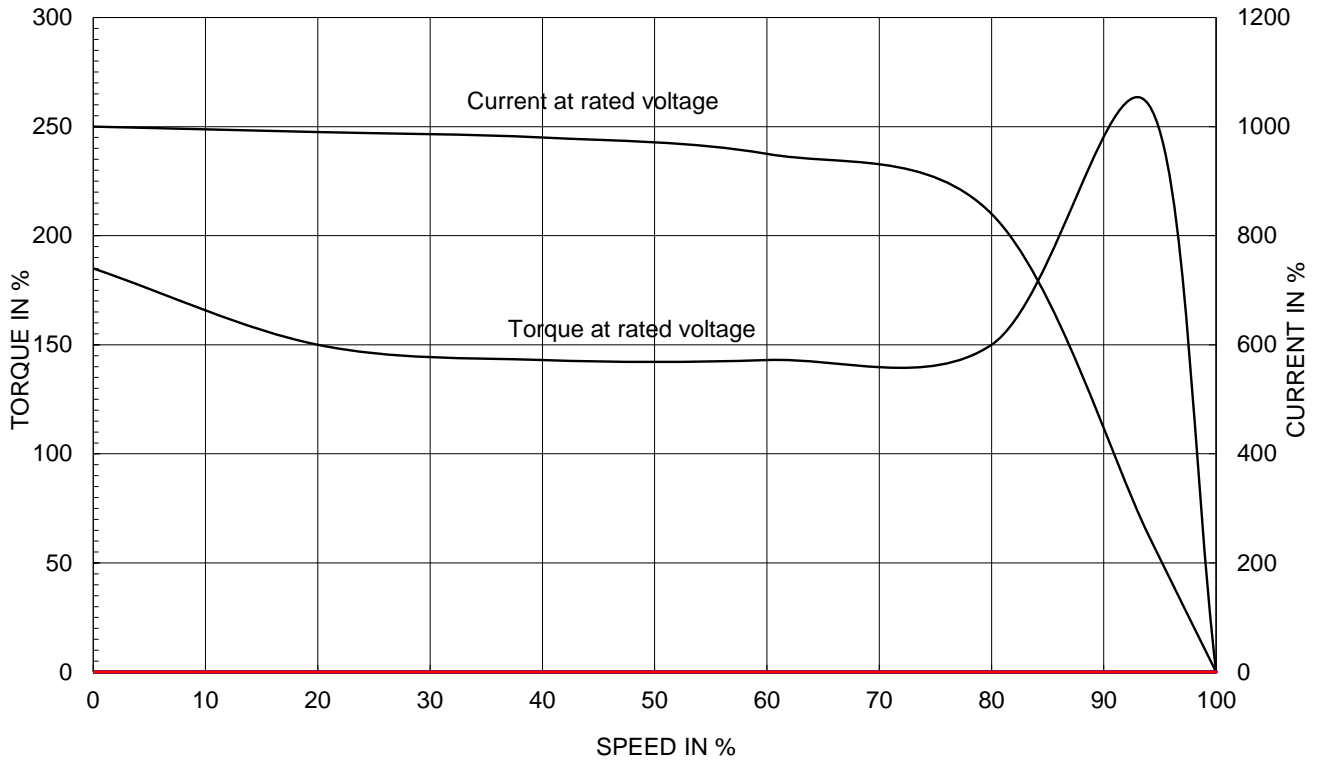

OUTPUT VS EFF., P.F & CURRENT CURVE

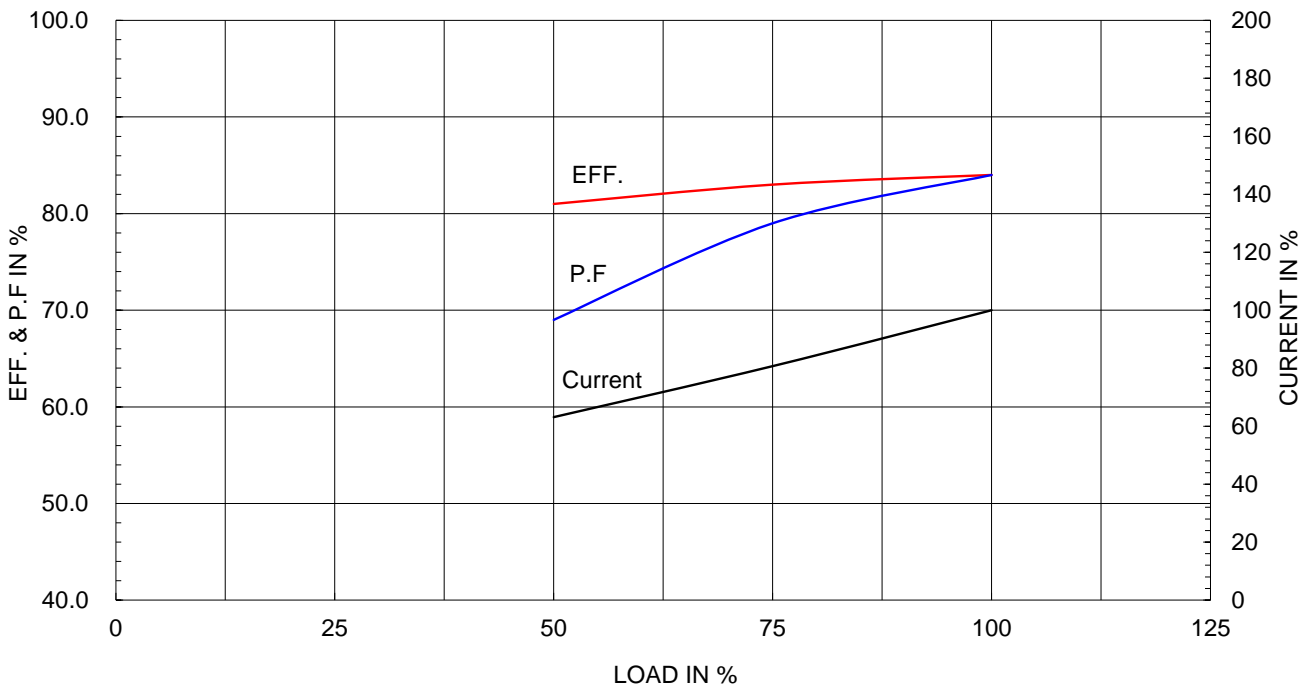

본 도면은 HD현대일렉트릭(주) 재산이며 허가없이 복사할 수 없음 (취급유의)

THIS DRAWING IS PROPRIETARY TO HYUNDAI ELECTRIC. NO PART OF THIS DRAWING MAYBE REPRODUCED WITHOUT THE PERMISSION OF HYUNDAI ELECTRIC.

▽	50S	REV	DATE	CONTENTS	REVD BY	CHKD BY	CHKD BY	APPD BY
▽▽	12.5S							
▽▽▽	3.2S							
▽▽▽▽	0.4S							

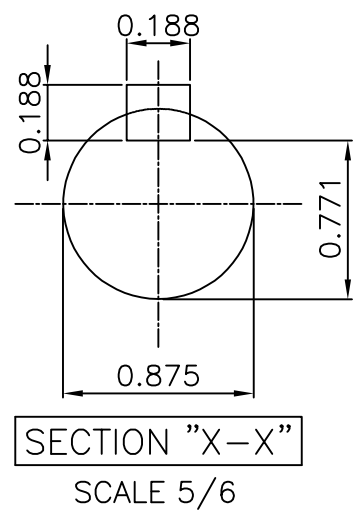
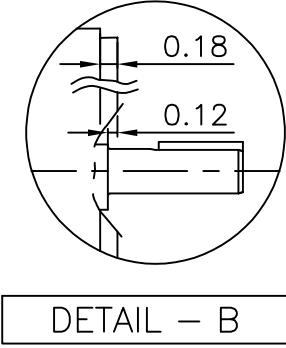
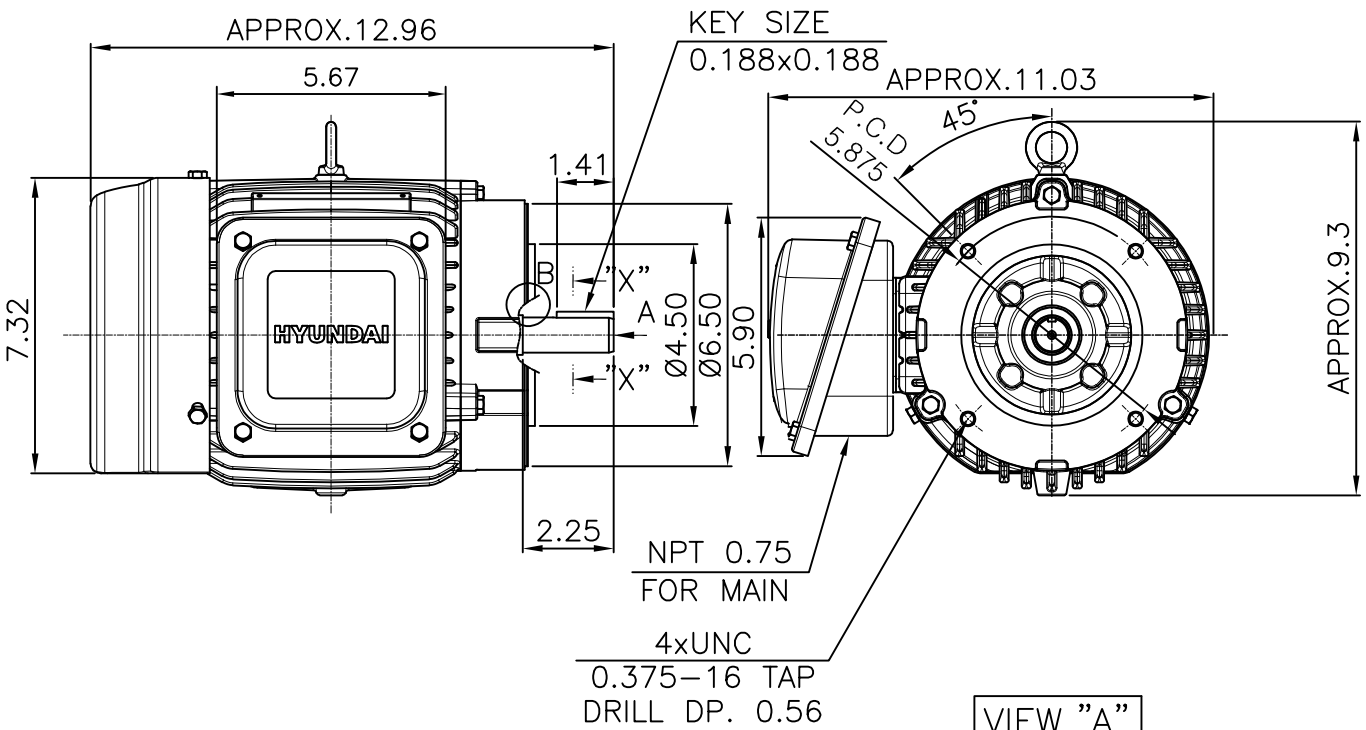

NOTE
 [TOLERANCE]

1. CENTER HEIGHT : +0.00inch - 0.03inch
2. SHAFT DIAMETER : +0.000inch - 0.0005inch
3. KEYWAY DEPTH : +0.000inch - 0.015inch

APPD BY	S.Y.KIM	UNIT	inch	SUBJECT	NEMA 143TC	DWG SIZE	A4 (1:5)
CHKD BY	R.G.KIM	SCALE	1/5	TITLE	OUTLINE	REF. NO	Sheet No. of
CHKD BY		PROJEC'N	3rd Angle				
DSND BY	주유람	DATE	2021-04-28				
				DWG NO	LM-T214-3C5PLV23	Revision No. 0	

**Cls. I&II, Div. 2
IEEE 841**

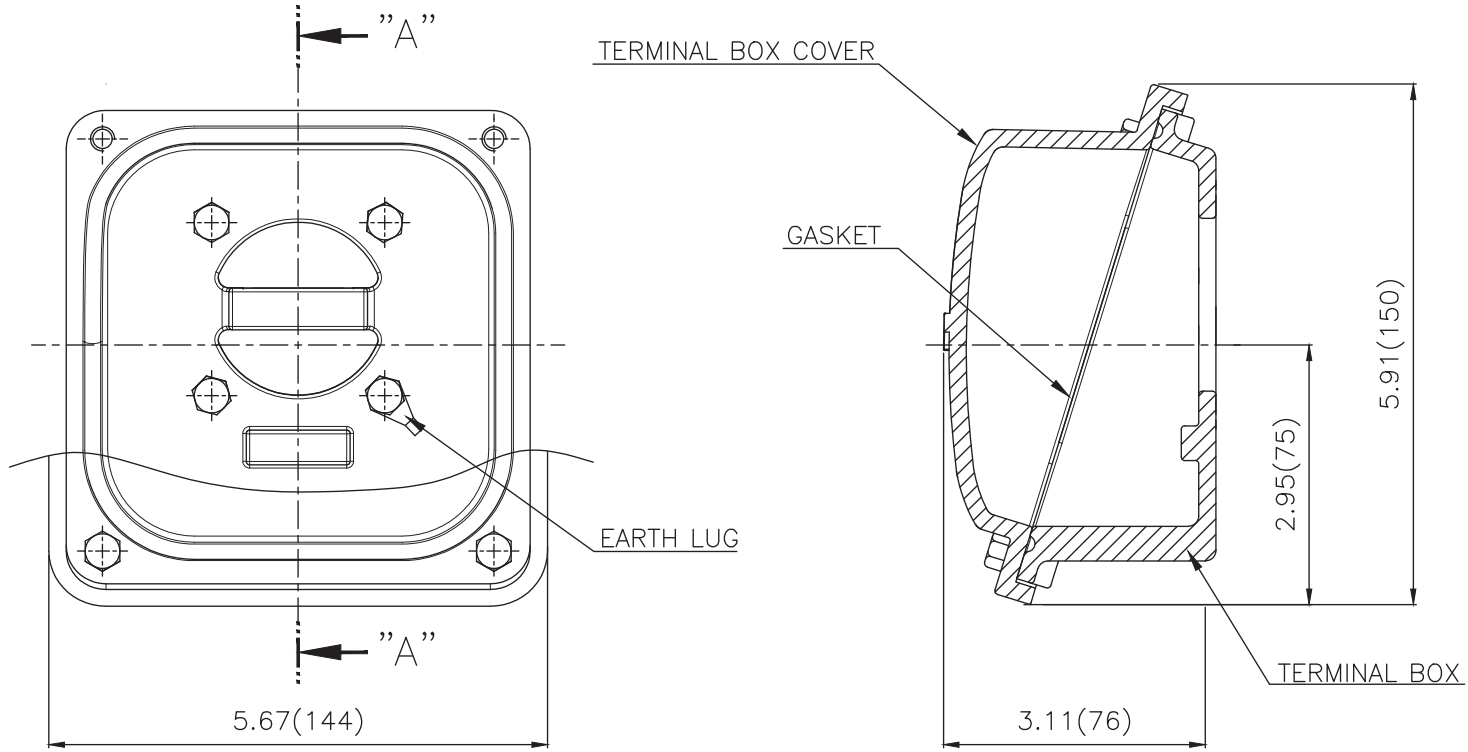

SEC. "A"-"A"

▽	50S
▽▽	12.5S
▽▽▽	3.2S
▽▽▽▽	0.4S

REV	DATE	CONTENTS	REVD BY	CHKD BY	CHKD BY	APPD BY

일반가공공차		일반제관공차	
1-4	±0.1	6-30	±0.5
4-18	±0.2	30-120	±0.8
18-63	±0.3	120-315	±1.2
63-250	±0.5	315-1000	±2.0
250-	±0.8	1000-	±3.0

Q'TY	DESCRIPTION	MATERIAL	DIMENSION	WEIGHT	PART NO.	REMARK	NO.
APPD BY	S.Y.KIM	UNIT	inch(mm)	SUBJECT	FR. 140-180 (CAST IRON)	DWG SIZE	
CHKD BY		SCALE	1/1.5	TITLE	TERMINAL BOX ASS'Y		
CHKD BY	R.G.KIM	PROJEC'N	3rd Angle	DATE	2023-10-19		
DSND BY	배승희						
REF. NO		Sheet No.	of	DWG NO	3M-248456	Revision No.	0

